

## **Disclaimer**

The following online version of the Owner's Manual describes all models as well as all the standard and optional equipment of your vehicle. Country-specific differences in the language variants are possible. Note that your vehicle may not be fitted with all features described. This is also the case for safety-relevant systems and functions. Please contact your authorised Mercedes-Benz dealer if you would like to have a printed Owner's Manual for other vehicle models and vehicle model years. The online version is the current valid Owner's Manual version. Possible variations to your vehicle may not be taken into account as Mercedes-Benz constantly updates their vehicles and equipment to the state of the art and introduces changes in design and equipment. Please also read the printed Owner's Manual, any supplementary documents and the digital Owner's Manual in the vehicle.

## **Copyright**

All Rights Reserved. All texts, images, graphics, are subject to Copyright and other laws for the protection of intellectual property. They may not be copied for commercial purposes or for transmission, nor changed and used on other websites.





# V-Class

Owner's Manual

Mercedes-Benz



## Front passenger airbag warning



**▲ WARNING** Risk of injury or death if the co-driver airbag is enabled

If the co-driver airbag is enabled, a child on the co-driver seat may be struck by the co-driver airbag during an accident.

NEVER use a rearward-facing child restraint system on a seat with an ENABLED FRONT AIRBAG; DEATH or SERIOUS INJURY to the CHILD can occur.

Observe the chapter "Children in the vehicle".

## Welcome to the world of Mercedes-Benz

Before you first drive off, read these Operating Instructions carefully and familiarise yourself with your vehicle. For your own safety and a longer operating lifespan, follow the instructions and warning notices in these Operating Instructions. Disregarding them may result in damage to the vehicle or environment or in injuries to people.

The standard equipment and product description of your vehicle may vary and depends on the following factors:

- Model
- Order
- National version
- availability

The illustrations in these Operating Instructions show a left-hand drive vehicle. On right-hand-drive vehicles, the layout of car parts and control elements differs accordingly.

Mercedes-Benz is constantly developing its vehicles further.

Mercedes-Benz therefore reserves the right to introduce changes in the following areas:

- Design
- Equipment
- Technical features

Your vehicle may therefore differ, in individual cases, from that shown in the descriptions and illustrations.

The following documents are integral parts of the vehicle:

- Digital Operating Instructions
- printed Operating Instructions
- service booklet
- equipment-dependent supplements

Always keep these documents in the vehicle. If you sell the vehicle, always pass all documents on to the new owner.



<b>Symbols</b> .....	<b>4</b>	Sliding door .....	56
<b>At a glance</b> .....	<b>6</b>	Electric sliding door .....	57
Cockpit .....	6	Tailgate .....	60
Indicator and warning lamps .....	7	Side window .....	63
Steering wheel with buttons .....	8	Panorama sliding sunroof .....	66
Centre console .....	9	Anti-theft prevention .....	69
Overhead control panel .....	13	<b>Seats and stowage</b> .....	<b>72</b>
Door control panel .....	14	Notes on the correct driver's seat posi- tion .....	72
<b>Digital Operating Instructions</b> .....	<b>15</b>	Seats .....	72
Calling up the Digital Operating Instruc- tions .....	15	Steering wheel .....	100
<b>General notes</b> .....	<b>16</b>	Stowage areas .....	100
Environmental protection .....	16	Folding table .....	102
Take-back of end-of-life vehicles .....	16	Folding the folding table in and out on the seat backrest .....	104
Mercedes-Benz GenuineParts .....	16	Information about the bottle holder .....	105
Information about attachments, add-on equipment, installations and conver- sions .....	17	Cup holders .....	105
Operating Instructions .....	17	Ashtray and cigarette lighter .....	105
Operating safety .....	18	Sockets .....	106
Declarations of conformity and notes on driving in different countries .....	19	Switching the refrigerator box in the centre console on and off .....	108
Diagnostics connection .....	24	Notes on attaching the iPad® .....	108
Notes on changes to the engine output .....	25	<b>Light and vision</b> .....	<b>109</b>
Qualified specialist workshop .....	25	Exterior lighting .....	109
Vehicle registration .....	25	Adjusting the interior lighting .....	114
Correct use of the vehicle .....	25	Changing bulbs .....	115
Information on the REACH directive .....	26	Windscreen wipers .....	120
Notes for persons with electronic medi- cal aids .....	26	Mirrors .....	122
Implied warranty .....	26	Operating sun visors .....	124
QR codes for rescue card .....	26	<b>Climate control</b> .....	<b>125</b>
Data storage .....	26	Overview of climate control systems .....	125
Copyright .....	29	Operating climate control systems .....	127
<b>Occupant safety</b> .....	<b>30</b>	Operating air vents .....	131
Restraint system .....	30	Auxiliary heating .....	131
Seat belts .....	31	<b>Driving and parking</b> .....	<b>138</b>
Airbags .....	34	Driving .....	138
PRE-SAFE® System .....	39	Manual transmission .....	143
Automatic measures after an accident .....	39	Automatic transmission .....	143
Safely transporting children in the vehi- cle .....	39	All-wheel drive .....	147
Notes on pets in the vehicle .....	51	AIRMATIC .....	147
<b>Opening and closing</b> .....	<b>52</b>	Refuelling .....	148
Key .....	52	Parking .....	152
Doors .....	54	Driving and driving safety systems .....	154
		Trailer operation .....	179

<b>Instrument cluster and on-board computer</b> .....	<b>184</b>
Overview of the instrument cluster .....	184
Overview and operation of the on-board computer .....	184
Overview of data shown on the instrument cluster display .....	186
Adjusting the instrument lighting .....	186
Overview of menus on the on-board computer .....	186
Menus and submenus .....	187

<b>Mercedes me</b> .....	<b>194</b>
Mercedes me calls .....	194
Mercedes me connect .....	196
Mercedes me and apps .....	197

<b>MBUX multimedia system</b> .....	<b>199</b>
Overview and operation .....	199
System settings .....	202
Navigation .....	205
Telephone .....	210
Overview of Smartphone Integration .....	212
Web browser overview .....	213
Radio and media .....	213
Sound settings .....	216

<b>Transporting</b> .....	<b>217</b>
Notes on loading guidelines .....	217
Notes on distributing the load within the vehicle .....	218
Securing loads .....	219
Load securing aid .....	221
Carrier systems .....	224

<b>Maintenance and care</b> .....	<b>226</b>
Notes on maintenance .....	226
Service interval display .....	226
Engine compartment .....	227
Cleaning and care .....	233

<b>Breakdown assistance</b> .....	<b>238</b>
Emergency .....	238
Mercedes-Benz emergency call system ....	239
Flat tyre .....	241
Battery .....	241
Towing or tow-starting .....	248
Electrical fuses .....	253
Vehicle tool kit .....	253

<b>Wheels and tyres</b> .....	<b>255</b>
Information on noise or unusual driving characteristics .....	255
Notes on regularly inspecting wheels and tyres .....	255
Information on driving with summer tyres .....	255
Information on M+S tyres .....	255
Notes on snow chains .....	256
Tyre pressure .....	256
Changing a wheel .....	261
Information on wheel and tyre combinations .....	266
Spare wheel .....	269

<b>Technical data</b> .....	<b>272</b>
Information on the technical data .....	272
On-board electronics .....	272
Regulatory radio identifications and notes .....	273
Vehicle identification plate, vehicle identification number (VIN) and engine number .....	273
Operating fluids and capacities .....	274
Vehicle data .....	281
Trailer hitch .....	282
Lashing points and carrier systems .....	283

<b>Display messages and warning and indicator lamps</b> .....	<b>284</b>
Display messages .....	284
Warning and indicator lamps .....	307

<b>Index</b> .....	<b>316</b>
--------------------	------------

In these Operating Instructions, you will find the following symbols:

 **WARNING** Danger due to not observing the warning notices

Warning notices draw your attention to hazards that may endanger your health or life, or the health or life of others.

► Observe the warning notices.

 **ENVIRONMENTAL NOTE** Environmental damage due to failure to observe environmental notes

Environmental notes include information on environmentally responsible behaviour or environmentally responsible disposal.

► Observe environmental notes.

 **NOTE** Damage to property due to failure to observe notes on material damage

Notes on material damage inform you of risks which may lead to your vehicle being damaged.

► Observe notes on material damage.

 These symbols indicate useful instructions or further information that could be helpful to you.

► Instructions

(→ Further information on a topic page)

Display Messages on the display





 Highest menu level to be selected in the multimedia/audio system

 Corresponding submenus to be selected in the multimedia/audio system

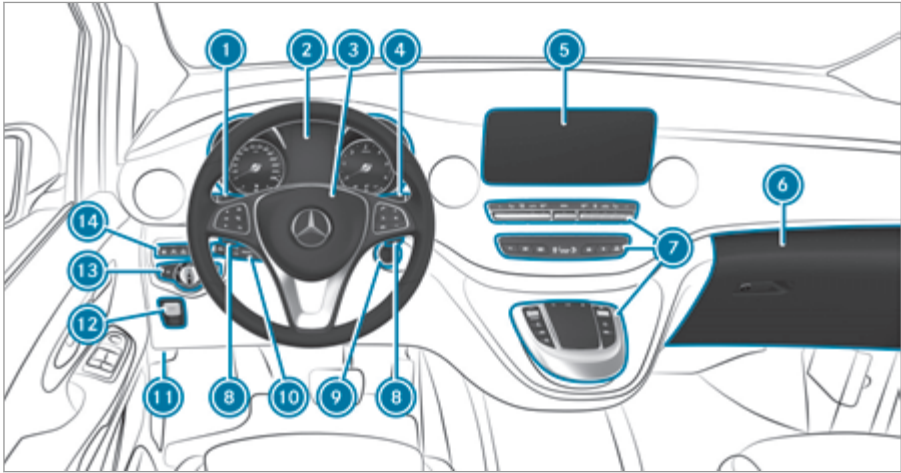
\* Indicates a cause





① Combination switch	→	110	⑨ Ignition lock	→	138
② Instrument cluster	→	184	⑩ Cruise control lever	→	159
③ Adjusts the steering wheel	→	100	⑪ Diagnostics connection	→	24
Horn			 Opens the bonnet	→	227
④ DIRECT SELECT lever (auto- matic transmission)	→	143	⑫ Parking brake	→	152
⑤ Multimedia system display			⑬ Light switch	→	109
⑥ Glove compartment	→	101	⑭ Driving systems control panel:		
⑦ Centre console operating units			 Lane Keeping Assist	→	178
⑧ Steering wheel gearshift pad- dles (automatic transmission)	→	146	 DSR	→	161
			 360° camera	→	170

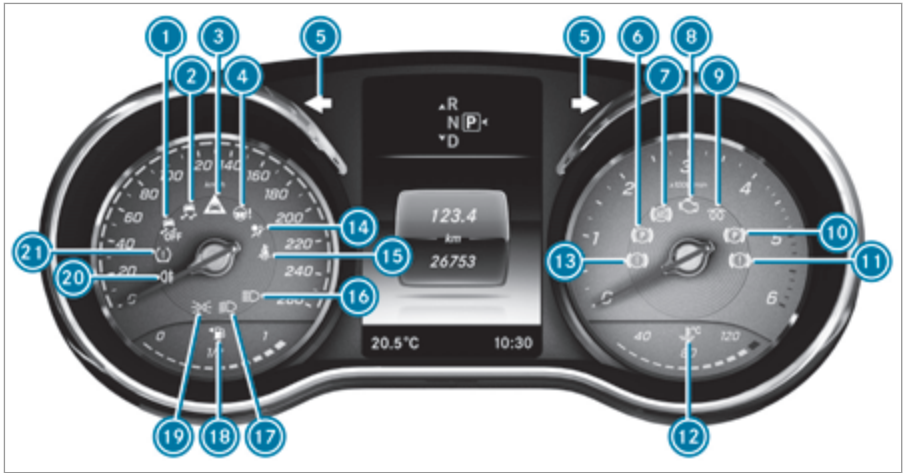



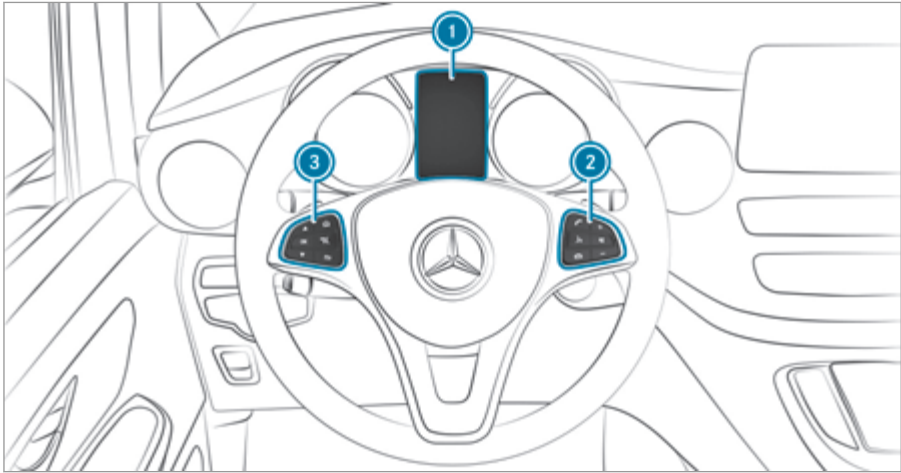



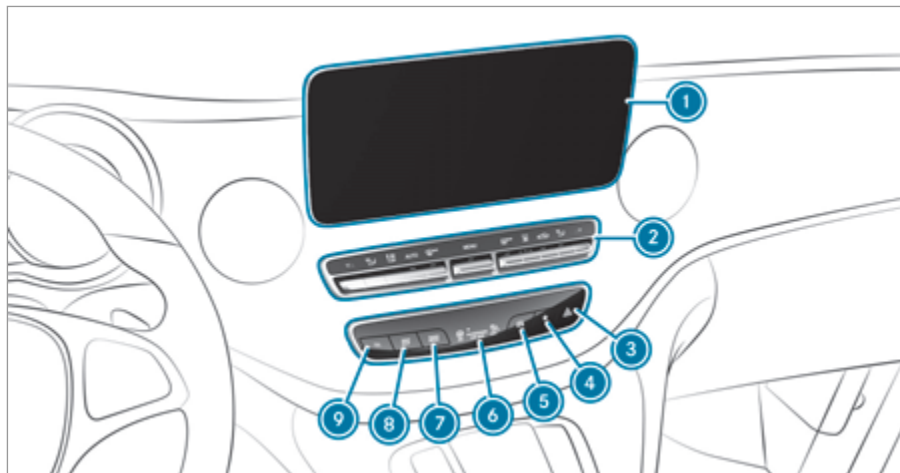

1	ESP® OFF	→	307	14	Restraint system	→	307
2	ESP®	→	307	15	Seat belt	→	311
3	Distance warning	→	311	16	High beam	→	110
4	Power steering	→	312	17	Low beam	→	109
5	Turn signal lights	→	110	18	Reserve fuel	→	312
6	Parking brake (yellow)	→	307	19	Standing lights and licence plate and instrument lighting	→	109
7	ABS	→	307	20	Rear fog light	→	109
8	Engine diagnostics	→	312	21	Tyre pressure monitoring system	→	314
9	Diesel engine: preglow				Corresponding messages may also be shown on the instrument cluster display.	→	284
10	Parking brake (red)	→	307				
11	Brakes (red)	→	307				
12	Coolant	→	312				
13	Brakes (yellow) inoperative						



① Display	→	186	③  Calls up the main menu	→	184
②  Ends or declines calls/ exits the phone book or redial memory	→	191	Selects a menu or submenu or scrolls through lists		
Makes or accepts calls/ switches to the redial memory			Confirms a selection/ hides display messages		
Adjusts the volume			Back		
Mutes			Deactivates LINGUA- TRONIC	→	201
Activates LINGUATRONIC	→	201			

## Centre console, upper section





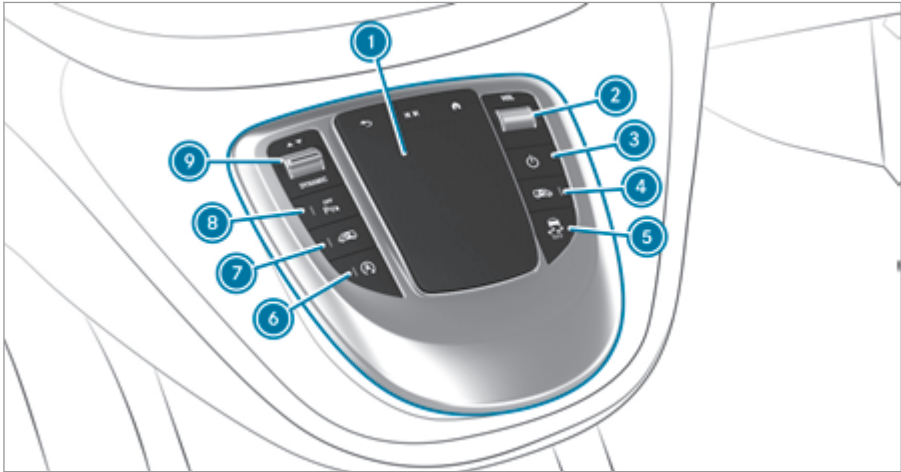

① Multimedia system display			
② Climate control system operating unit	→	125	
③  Switches the hazard warning light system on/off	→	110	
④  Calls up favourites	→	200	
⑤  Calls up vehicle functions			
⑥  PASSENGER AIR BAG indicator lamps	→	37	
⑦  Calls up radio or media	→	200	
⑧  Calls up navigation	→	205	
⑨  Calls up the telephone	→	211	

Centre console, middle section



Vehicle with automatic transmission (example)

① Touchpad	→	200	⑥  Switches the ECO start/stop function on/off	→	142
② Adjusts and mutes the volume			⑦  Opens/closes the electric sliding door on the left side of the vehicle	→	58
③ Switches the multimedia system on/off			⑧  Switches PARKTRONIC on/off	→	168
④  Opens/closes the electric sliding door on the right side of the vehicle	→	58	⑨ DYNAMIC SELECT switch	→	146
⑤  Switches ESP® on/off	→	155			

## Centre console, lower section

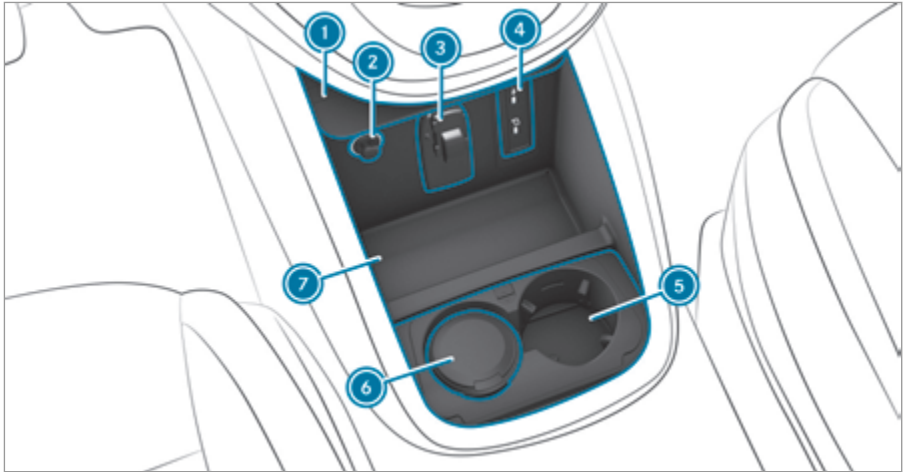

## Stowage compartment with cover

① Cover	→	100	⑤ Cup holders		
② 12 V socket	→	106	⑥ Ashtray	→	105
Cigarette lighter	→	106	⑦ Stowage compartment		
③ Holder for the mobile phone bracket			Switch clock for auxiliary warm-air heater	→	135
④ Media Interface with two USB ports or with two USB ports and one SD card slot			Device installation frame for auxiliary equipment, e.g. a tachograph		

Centre console between the driver's and front passenger seats

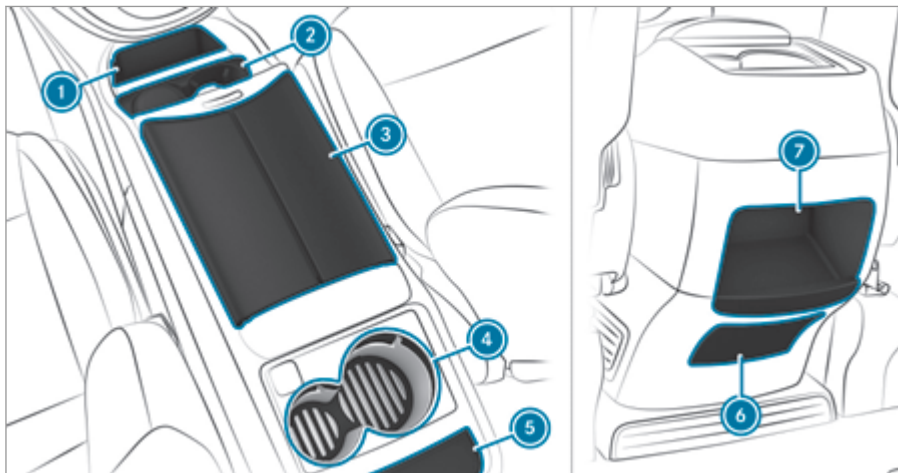

① Stowage compartment	⑤ Stowage compartment		
② Cup holders	⑥ Cigarette lighter	→	106
③ Stowage compartment	Ashtray	→	106
Media Interface with two USB ports and an SD card slot	12 V socket	→	107
Refrigerator box	230 V socket	→	107
④ Temperature-controlled cup holder	⑦ Stowage compartment		

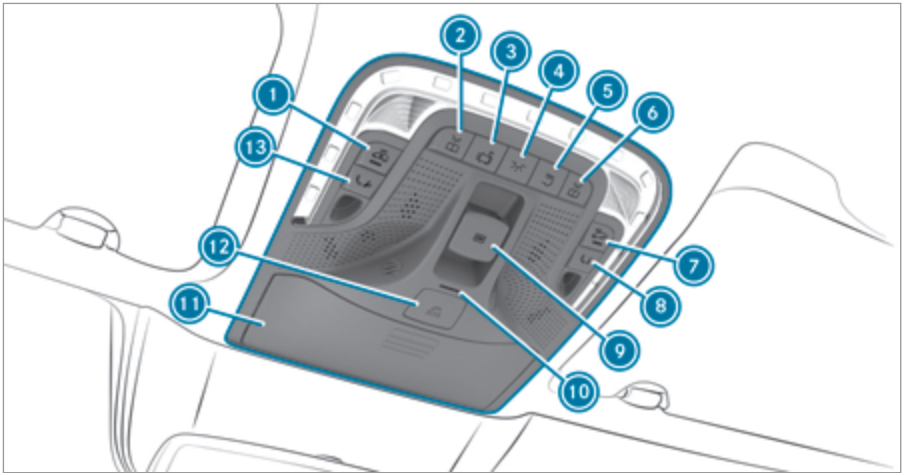

①		Deactivates interior protection	→	70	⑧		Button for Info call	→	194
②		Switches the left-hand reading lamp on/off	→	114	⑨		Opens/closes the panorama sliding sunroof	→	67
③		Switches automatic interior lighting control on/off	→	114			Opens/closes the roller sunblinds	→	67
④		Switches the front interior lighting on/off	→	114	⑩		ATA indicator lamp	→	69
⑤		Switches the rear/load compartment lighting on/off	→	114	⑪		Glasses compartment	→	101
⑥		Switches the right-hand reading lamp on/off	→	114	⑫		SOS button	→	239
⑦		Deactivates tow-away protection	→	70	⑬		Breakdown assistance call button	→	194

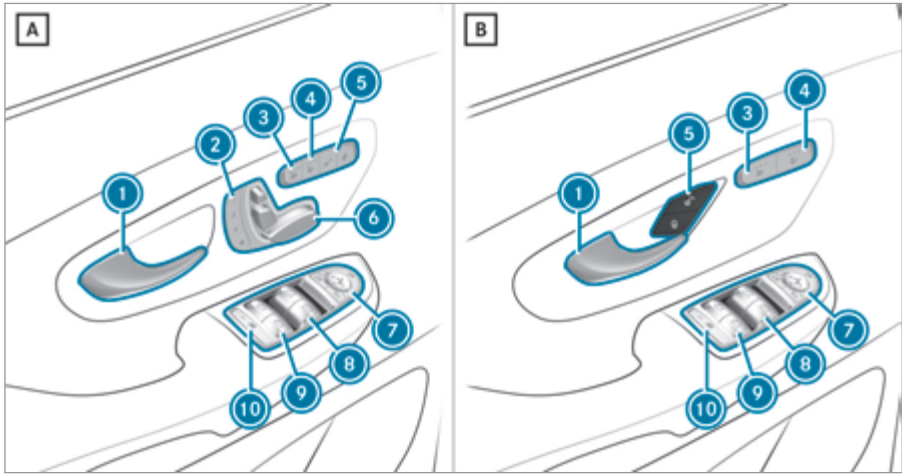

<b>A</b> Vehicles with electrically adjustable front seats			
<b>B</b> Vehicles with manually adjustable front seats			
<b>1</b> Opens a door	→	54	
<b>2</b> <b>M</b> <b>1</b> <b>2</b> <b>3</b> Saves the seat and exterior mirror settings	→	76	
<b>3</b> Seat heating	→	98	
<b>4</b> Seat ventilation	→	99	
<b>5</b> Unlocks/locks the vehicle	→	55	
	<b>6</b> Adjusts the seat electrically	→	74
	<b>7</b> Adjusts and folds the exterior mirrors in/out electrically	→	122
	<b>8</b> Opens/closes the front side windows	→	63
	<b>9</b> Opens/closes rear hinged windows	→	64
	<b>10</b> Disables/enables rear-compartment hinged window controls (override feature)	→	51

## Calling up the Digital Operating Instructions

Multimedia system:

↳ Info ▶▶ Owner's Manual ▶▶ ⓘ



The Digital Operating Instructions describe the function and operation of the vehicle and the multimedia system.

- ▶ Select one of the following menu items in the Digital Operating Instructions:
  - **Search:** here you can use keywords to quickly locate answers to questions concerning vehicle operation.
  - **Quick start:** Here you will find the first steps for setting up the driver's seat.
  - **Tips:** provides you with information on specific everyday situations for your vehicle.
  - **Bookmarks:** you can access your saved personal bookmarks here.
  - **Language:** you can set the language for the Digital Operating Instructions here.

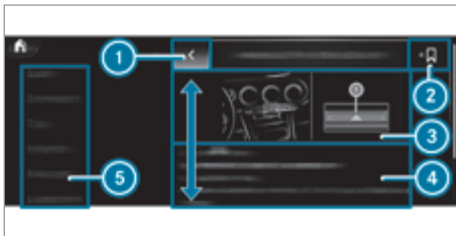

- ① Back
- ② Add bookmarks
- ③ Picture
- ④ Content area
- ⑤ Menu

Some sections in the Digital Operating Instructions, such as warning notes, can be expanded and collapsed.

## Additional options for calling up the Digital Operating Instructions

- ▶ **Direct access:** pressing and holding down an entry in the tab bar of the multimedia system opens the corresponding content in the Digital Operating Instructions.



- ▶ **LINGUATRONIC:** calls up via the voice control system

The Digital Operating Instructions are deactivated for safety reasons while driving.

- ⓘ The Operating Instructions can also be found in the Mercedes-Benz Guides App in all common app stores.

## Environmental protection

 **ENVIRONMENTAL NOTE** Environmental damage due to operating conditions and personal driving style

The pollutant emission of the vehicle is directly related to the vehicle's operation.

Operate the vehicle in an environmentally responsible manner to make a contribution to environmental protection. To do this, observe the following recommendations on operating conditions and your personal driving style.

### Operating conditions:

- ▶ Make sure that the tyre pressures are always correct.
- ▶ Do not transport any unnecessary weight (e.g. a roof luggage rack which is no longer required).
- ▶ Observe the service intervals. A regularly serviced vehicle will contribute to environmental protection.
- ▶ Always have maintenance work carried out at a qualified specialist workshop.

### Personal driving style:

- ▶ Do not depress the accelerator pedal when starting the engine.
- ▶ Do not warm up the vehicle while stationary.
- ▶ Drive carefully and maintain a sufficient distance to other vehicles.
- ▶ Avoid frequent, sudden acceleration and braking.
- ▶ Shift gears in good time and use each gear only up to  $\frac{2}{3}$  of its maximum engine speed.
- ▶ Switch off the vehicle in stationary traffic, e.g. by using the ECO start/stop function.
- ▶ Drive in a fuel-efficient manner. Pay attention to the ECO display for a fuel-efficient driving style.

## Take-back of end-of-life vehicles

### EU countries only:

Mercedes-Benz will take back your end-of-life vehicle for environment-friendly disposal in accordance

with the European Union (EU) End-Of-Life Vehicles Directive.

A network of vehicle take-back points and dismantlers has been established for you to return your vehicle. You can leave it at any of these points free of charge. This makes an important contribution to closing the recycling circle and conserving resources.

For further information about the recycling and disposal of end-of-life vehicles, and the take-back conditions, please visit the national Mercedes-Benz website for your country.

## Mercedes-Benz GenuineParts

 **ENVIRONMENTAL NOTE** Environmental damage caused by not using recycled/reconditioned components

Mercedes-Benz AG offers recycled/reconditioned components and parts with the same quality as new parts. The same entitlement from the implied warranty is valid as for new parts.

- ▶ Recycled/reconditioned components and parts from Mercedes-Benz AG.

 **NOTE** Impairment of the operating efficiency of the restraint systems from installing accessory parts or from repairs or welding

Airbags and seat belt tensioners, as well as control units and sensors for the restraint systems, may be installed in the following areas of your vehicle:

- doors
- door pillars
- door sills
- seats
- cockpit
- instrument cluster
- centre console

▶ Do not install accessories such as audio systems in these areas.

▶ Do not carry out repairs or welding.

▶ Have accessory parts retrofitted at a qualified specialist workshop.

If you use parts, tyres, wheels or safety-relevant accessories which have not been approved by Mercedes-Benz, the operating safety of the vehicle may be jeopardised. Safety-relevant systems, e.g. the brake system, may malfunction. Use only genuine Mercedes-Benz GenuineParts or parts of equal quality. Use only tyres, wheels and accessory parts that are approved for your vehicle model.

Mercedes-Benz tests original parts, conversion parts and accessory parts that have been approved for your vehicle model for reliability, safety and suitability. Despite ongoing market research, Mercedes-Benz is unable to assess other parts. Mercedes-Benz accepts no responsibility for the use of such parts in Mercedes-Benz vehicles, even if they have been approved officially or independently by a testing centre.

Certain parts are only officially approved for installation or modification if they comply with legal requirements. All genuine Mercedes-Benz GenuineParts meet the registration requirements. The use of non-approved parts may invalidate the vehicle's general operating permit.

This is the case in the following situations:

- The vehicle type changes from that stated in the general operating permit.
- Other road users could be endangered.
- The exhaust gas or noise levels are adversely affected.

Always specify the vehicle identification number (VIN) and engine number when ordering genuine Mercedes-Benz GenuineParts (→ page 273).

### Information about attachments, add-on equipment, installations and conversions

#### Notes on body/equipment mounting directives

For safety reasons, have add-on equipment produced and fitted in accordance with the valid Mercedes-Benz body/equipment mounting directives. These body/equipment mounting directives ensure that the chassis and add-on equipment form one unit and that the greatest possible level of operational and driving safety is achieved.

Both vehicle manufacturers and body manufacturers must always ensure that the products they manufacture come into circulation only in a safe state and do not pose any risks to people. Otherwise, there may be consequences under civil, criminal or public law. All manufacturers are responsible for the products that they have manufactured. Manufacturers of attachments, add-on equipment,

installations and conversions must guarantee compliance with Directive 2001/95/EC on general product safety.

Mercedes-Benz recommends the following procedure for safety reasons:

- Do not make any other changes to the vehicle.
- Obtain approval from Mercedes-Benz in the event of deviations from the approved body/equipment mounting directives.

Acceptance tests performed by public test bodies or official approvals do not rule out safety risks.

Comply with the information about Mercedes-Benz genuine parts (→ page 16).

You will find the Mercedes-Benz body/equipment mounting directives online at the <https://bb-portal.mercedes-benz.com/en/GLOBAL>

You will also find information about the PIN assignment and changing the fuse there.

-  You can obtain further information at a qualified specialist workshop.

**⚠ WARNING** Risk of accident and injury in the event of improper conversions or changes to the vehicle

Conversions or changes to the vehicle can prevent systems or components from functioning properly and/or jeopardise the vehicle's operational safety.

-  Always have conversions or changes to the vehicle carried out at a qualified workshop.

#### Notes on the radiator

Even seemingly minor changes to the vehicle, such as attaching a radiator grille in winter, are not permitted. Do not cover the radiator. Do not use any thermal mats, insect protection covers etc.

Otherwise, the values of the vehicle's diagnostic system will be distorted. In some countries, the recording of engine diagnostics data is prescribed by law and must be verifiable and correct at all times.

### Operating Instructions

These Operating Instructions describe all models, as well as standard and optional equipment of your vehicle that was available at the time of going to press. Country-specific differences are possible. Note that your vehicle may not be fitted with all functions described. This is also the case for sys-

tems and functions relevant to safety. Therefore, the equipment on your vehicle may differ from that in the descriptions and illustrations.

The original purchase agreement documentation for your vehicle contains a list of all the systems in your vehicle.

Should you have any questions concerning equipment and operation, consult a Mercedes-Benz Service Centre.

The Operating Instructions and Service Booklet are important documents and should be kept in the vehicle.

### Note on vehicles which are equipped by body manufacturers

Always observe the body manufacturer's Operating Instructions. You could otherwise fail to recognise dangers.

## Operating safety

### **⚠ WARNING** Risk of accident due to malfunctions or system failures

If you do not have the prescribed service/maintenance work or any required repairs carried out, this could result in malfunctions or system failures.

- ▶ Always have the prescribed service and maintenance work as well any required repairs carried out at a qualified specialist workshop.

### **⚠ WARNING** Risk of accident or injury due to improper modifications to electronic components

Modifications to electronic components, their software or wiring can impair their functionality and/or the functionality of other networked components or safety-relevant systems.

This can endanger the vehicle's operating safety.

- ▶ You must not tamper with wiring, electronic components, or their software.
- ▶ Always have work on electrical and electronic devices carried out at a qualified specialist workshop.

If you make any changes to the on-board electronics, the general operating permit will be rendered invalid.

Observe the "Vehicle electronics" section in "Technical data".

### **⚠ WARNING** Risk of fire due to flammable materials on hot parts of the exhaust system

Flammable material such as leaves, grass or twigs may ignite if they come into contact with hot parts of the exhaust system.

- ▶ When driving on unpaved roads or off-road, regularly check the vehicle underside.
- ▶ Remove trapped plants or other flammable material, in particular.
- ▶ If there is damage, consult a qualified specialist workshop immediately.

### **! NOTE** Damage to the vehicle due to driving too fast and due to impacts to the vehicle underbody or suspension components

In the following situations, in particular, there is a risk of damage to the vehicle:

- the vehicle becomes grounded, e.g. on a high kerb or an unpaved road
- the vehicle is driven too fast over an obstacle, e.g. a kerb, speed bump or pothole
- a heavy object strikes the underbody or suspension components

In situations such as these, damage to the body, underbody, suspension components, wheels or tyres may not be visible. Components damaged in this way can unexpectedly fail or, in the case of an accident, may no longer absorb the resulting force as intended.

If the underbody panelling is damaged, flammable materials such as leaves, grass or twigs can collect between the underbody and the underbody panelling. These materials may ignite if they come into contact with hot parts of the exhaust system.

- ▶ Have the vehicle checked and repaired immediately at a qualified specialist workshop.

or

- ▶ If driving safety is impaired while continuing your journey, pull over and stop the vehicle immediately, while paying attention to road and traffic conditions, and contact a qualified specialist workshop.

## Declarations of conformity and notes on driving in different countries

### Electromagnetic compatibility

The electromagnetic compatibility of the vehicle components has been checked and certified according to the currently valid version of Directive UN-R 10.

### Vehicle installed radio components

**Only for EU and EFTA countries and countries that recognise the EU manufacturer's declaration of conformity:**



The following information is valid for all wireless components in the vehicle as well as the information systems and communication devices integrated in the vehicle:

The manufacturers of the wireless components ensure that all wireless components installed in the vehicle conform to Directive 2014/53/EU. The full texts of the EU declarations of conformity are available at the following web address:

[https://moba.i.daimler.com/markets/ece-row/baix/cars/certificates-of-conformity/en\\_GB/index.html](https://moba.i.daimler.com/markets/ece-row/baix/cars/certificates-of-conformity/en_GB/index.html)



Further information is available from any Mercedes-Benz service centre.

### Israel only:

It is prohibited to make any change to a vehicle-installed radio component that could affect the wireless specifications of the device, including

software changes, replacement of the original antenna, or adding the option to connect the device to an external antenna, without first obtaining approval from the Communications Ministry, because of concern about wireless interference.

### United Kingdom only:



The following information is valid for all wireless components in the vehicle as well as the information systems and communication devices integrated in the vehicle:

The manufacturers of the radio components declare that all radio equipment installed in the vehicle is in compliance with the relevant statutory requirements. The full texts of the declarations of conformity are available at the following web address:

[https://moba.i.daimler.com/markets/ece-row/baix/cars/certificates-of-conformity/en\\_GB/index.html](https://moba.i.daimler.com/markets/ece-row/baix/cars/certificates-of-conformity/en_GB/index.html)



### Brazil only:



Note on the two-way radio system in the vehicle:

This system is not subject to protection against harmful interference and must not cause interference in properly approved systems.

**Russia only**

The manufacturers of the wireless components installed in the vehicle hereby declare that all wireless components installed in the vehicle conform to the technical regulations for two-way radios. Further information is available from any Mercedes-Benz service centre.

**Ukraine only:**

The manufacturers of the wireless components installed in the vehicle hereby declare that all wireless components installed in the vehicle conform to the technical regulations for two-way radios. Further information is available from any Mercedes-Benz service centre.

**Manufacturer's specification**

Subsequently you will find the postal address of manufacturers of radio components, that due to their size or nature do not allow to indicate this information on the equipment.

**Antenna Modules**

Hirschmann Car Communication GmbH, Stuttgarter Straße 45-51, 72654 Neckartenzlingen, Germany

**Block Heater Remote Control**

Digades GmbH, Äußere Weberstraße 20, 02763 Zittau, Germany

Eberspächer Climate Control Systems GmbH & Co. KG, Eberspächerstrasse 24, 73730 Esslingen, Germany

**Transmitter key**

HELLA GmbH & Co. KGaA, Rixbecker Straße 75, 59552 Lippestadt, Germany

**Wireless central locking**

Hirschmann Car Communication GmbH, Stuttgarter Straße 45 - 51, 72654 Neckartenzlingen, Germany

**Head unit NTG6 (MBUX)**

Harman Becker Automotive Systems GmbH, Becker-Goehring-Strasse 18, 76307 Karlsbad, Germany

**Remote Keys**

Continental Automotive France SAS, 1 Avenue Paul Ourliac, B.P. 83649, 31036 Toulouse, France

Huf Hülsbeck & Fürst GmbH & Co. KG, Steeger Straße 17, 42551 Velbert, Germany

Marquardt GmbH, Schloßstraße 16, 78604 Rietheim, Germany

**Mobile Communication & Telematics**

Alpine Electronics Inc., 20-1 Yoshima-Kogyodanchi, Iwaki-Shi Fukushima-Ken, Japan

Harman Becker Automotive Systems GmbH, Postfach 2260, 76303 Karlsbad, Germany

Yanfeng Visteon Automotive Trim Systems Co., Ltd., 1001 Qinzhou Rd(N), 200233 Shanghai, PR China

**Radar Sensors**

Autoliv Electronics ASP Inc., 26545 American Drive, Southfield, MI 48034, USA

Robert Bosch GmbH, Daimlerstraße 6, 71229 Leonberg, Germany

**Tyre Pressure Monitoring Sensors**

Huf Hülsbeck & Fürst GmbH & Co. KG, Steeger Straße 17, 42551 Velbert, Germany

Schrader Electronics Ltd., 11 Technology Park, Belfast Road, Antrim BT41 1QS, Northern Ireland

**Type of wireless application and specification in accordance with 2014/53/EU**

Besides the typical frequencies for mobile communication cars by Mercedes-Benz make use of the following automotive radio applications.

## Type of wireless application and specification in accordance with 2014/53/EU

Technology	Frequency range	Transmission output/magnetic field strength
Bluetooth	2.4 GHz ISM band (2400–2483.5 MHz)	≤ 100 mW EIRP
Block Heater Remote Control and Receiver	433 MHz (433.05–434.79 MHz)	≤ 10 mW ERP
Block Heater Remote Control and Receiver	868 MHz (868.0–868.6 MHz)	≤ 25 mW ERP
Block Heater Remote Control and Receiver	869 MHz (868.7–869.2 MHz)	≤ 25 mW ERP
Convenience central locking system	20 kHz (9–90 kHz)	≤ 72 dB $\mu$ A/m at 10m
Convenience central locking system	120 kHz (119–135 kHz)	≤ 42 dB $\mu$ A/m at 10m
Convenience central locking system, tyre pressure monitoring system	433 MHz (433.05–434.79 MHz)	≤ 10 mW ERP
76 GHz radar	76–77 GHz	≤ 55 dBm peak EIRP
RLAN	2.4 GHz (2400–2483.5 MHz) 5.8 GHz (5725–5875 MHz)	≤ 100 mW EIRP ≤ 25 mW EIRP
Hermes 2.1 (communication module)	GSM: EGSM900, Class 4	< +33 dBm ( $\pm 2$ dB)
	GSM: EGSM1800, Class 1	< +30 dBm ( $\pm 2$ dB)
	GSM: EGSM900 8-PSK, Class E2	< +27 dBm ( $\pm 3$ dB)
	GSM: EGSM1800 8-PSK, Class E2	< +26 dBm ( $\pm 3$ dB/-4 dB)
	UMTS 2100: WCDMA FDD B 1, Class 3	< +24 dBm ( $\pm 1$ dB/-3 dB)
	LTE: FDD B1/BIII, Class 3 LTE: TDD B38/B39/B40/B41, Class 3	< +23 dBm ( $\pm 2$ dB)
Onboard Logic Unit (OLU)	GSM 900 (880–915 MHz / 925–960 MHz)	33 dBm (2 W)
	GSM 1800 (1710–1785 MHz / 1805–1880 MHz)	30 dBm (1 W)
	WCDMA FDDI (1920–1980 MHz / 2110–2170 MHz)	24 dBm (0.25 W)
	WCDMA FDDVIII (880–915 MHz / 925–960 MHz)	24 dBm (0.25 W)
	LTE FDD1 (1920–1980 MHz / 2110–2170 MHz)	23 dBm (0.2 W)

Technology	Frequency range	Transmission output/magnetic field strength
	LTE FDD3 (1710–1785 MHz / 1805–1880 MHz)	23 dBm (0.2 W)
	LTE FDD7 (2500–2570 MHz / 2620–2690 MHz)	23 dBm (0.2 W)
	LTE FDD8 (880–915 MHz / 925–960 MHz)	23 dBm (0.2 W)
	LTE FDD20 (832–862 MHz / 791–821 MHz)	23 dBm (0.2 W)
	LTE TDD38 (2570–2620 MHz / 2570–2620 MHz)	23 dBm (0.2 W)

### Information on the specific absorption rate

France only:

The values have been determined and tested in accordance with Décret n° 2019-1186 regarding the indication of the specific absorption rate of radio-based vehicle components.

Further information and updates are available at the following Internet address:

[https://moba.i.daimler.com/baix/cars/SAR/fr\\_FR/index.html](https://moba.i.daimler.com/baix/cars/SAR/fr_FR/index.html)



### Information on the specific absorption rate

Vehicle components (designation in accordance with EU DoC)	SAR value in W/kg	Limit value to be used
Telephone system radio data transmission	0.24 W/kg	2 W/kg
Hermes 2.1	< 0.4 W/kg	2 W/kg
Compensator ECE DE003 & ECE DE004	< 0.2 W/kg	2 W/kg
DAI RSE	1.8 W/kg	2 W/kg
Tablet PC SM-T230NZ	0.7 W/kg	4 W/kg
NRCS2P	0.003 W/kg	2 W/kg
NTG7RSU	0.07 W/kg	2 W/kg

Vehicle components (designation in accordance with EU DoC)	SAR value in W/kg	Limit value to be used
NTG7 MID, NTG7 HIGH, NTG7 PREMIUM, NTG7 PREMIUM-PLUS, NTG7 MID LFT2, NTG7 HIGH LFT2, NTG7 PREMIUM LFT2, NTG7 PREMIUMPLUS LFT2	0.08 W/kg	2 W/kg
RAMSES 1.0 and 1.1	0.036 W/kg	2 W/kg
NTG6N MID/ENTRY, NTG6N HIGH, NTG6N HIGH2	0.199 W/kg	4 W/kg

### Importer information for wireless components

#### **Moldova only:**

##### **Importer**

S.C. GRAND PREMIUM S.R.L. Moldova  
mun. Chisinau, str. Hîncești sos., 2/2

#### **Turkey only:**

##### **Importer**

Mercedes Benz Otomotiv Ticaret ve Hizmetler A.Ş.  
Genel Merkez  
Akçaburgaz Mah. Süleyman Şah Cad. No: 6/1  
34522 Esenyurt/Istanbul

#### **Ukraine only:**

##### **Importer**

PJSC „AUTOCAPITAL“  
Velyka Vasylkivska str. 15/2  
01004 Kyiv  
Ukraine

#### **United Kingdom only:**

##### **Importer of Mercedes-Benz cars**

Mercedes-Benz Cars UK Limited  
Delaware Drive, Tongwell  
Milton Keynes, MK15 8BA  
England

##### **Importer of Mercedes-Benz vans**

Mercedes-Benz Vans UK Limited  
Delaware Drive, Tongwell  
Milton Keynes, MK15 8BA  
England

##### **Importer of Mercedes-Benz spare parts**

Mercedes-Benz Parts Logistics  
Delaware Drive, Tongwell

Milton Keynes, MK15 8BA  
England

### Jack

Copy and translation of the original declaration of conformity:

#### **EC declaration of conformity**

1.

The undersigned, representing

Manufacturer:

BRANO a.s.

74741 Hradec nad Moravicí, Opavská 1000,

Czech Republic

ID No.: 64-387-5933

VAT No.: CZ64-387-5933

herewith declares under our sole responsibility that the product:

2. a)

Name:

Jack

Type, number:

A) A 164 580 02 18, A 166 580 01 18

B) A 240 580 00 18

C) A 639 580 02 18

Year of manufacture: 2015

Complies with all relevant provisions

Directive No. 2006/42/EG

b)

Description and purpose of use:

The jack is only intended for raising the specified vehicle in accordance with the operating instructions affixed to the jack.

3.

Reference data of the harmonised standards or specifications

A) ISO 4063, EN ISO 14341-A, DBL 7382.20, MBN 10435, AS 2693

B) ISO 4063, ISO 14341-A, DBL 7392.10, MBN 10435

C) DBL 7392.10, DBL 8230.10

Technical documentation of the product is stored at the premises of the manufacturer. The person responsible for assembling the technical documentation of the product: Head of the technical department Brano a.s.

4.

Hradec nad Moravicí

City

5.

05.05.2015

Date

Signed by:

Director of Quality

### Diagnosics connection

The diagnostics connection is a technical interface in the vehicle. It is used, for example, in the context of repair and maintenance work or for reading out vehicle data in a specialist workshop. Diagnostic devices should therefore only be connected in a qualified specialist workshop.

**⚠ WARNING** Risk of accident due to connecting devices to the diagnostics connection

If you connect devices to the diagnostics connection of the vehicle, the function of vehicle systems and operating safety may be impaired.

▶ For safety reasons, we recommend that you only use and connect products approved by your Mercedes-Benz service centre.

**⚠ WARNING** Risk of accident due to objects in the driver's footwell

Objects in the driver's footwell may impede pedal travel or block a depressed pedal.

This jeopardises the operating and road safety of the vehicle.

- ▶ Stow all objects in the vehicle securely so that they cannot get into the driver's footwell.
- ▶ Always fit the floor mats securely and as prescribed in order to ensure that there is always sufficient room for the pedals.
- ▶ Do not use loose floor mats and do not place floor mats on top of one another.

**!** **NOTE** Battery discharging from using devices connected to the diagnostics connection

Using devices at the diagnostics connection drains the battery.

- ▶ Check the charge level of the battery.
- ▶ If the charge level is low, charge the battery, e.g. by driving a considerable distance.

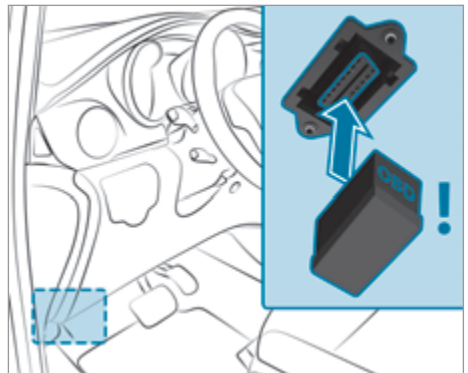

The connection and use of another device on the diagnostics connection can have the following effects:

- Malfunctions in the vehicle system
- Permanent damage to vehicle components

Please refer to the warranty terms and conditions regarding this.

In addition, connecting equipment to the diagnostics connection can lead to emissions monitoring information being reset, for example. This may lead to the vehicle failing to meet the requirements of the next emissions inspection during the main inspection.

### Notes on changes to the engine output

Output increases can cause:

- Change the emission values.
- Lead to malfunctions.
- Result in consequential damage.

The operating safety of the vehicle is not guaranteed in all situations.

If the vehicle's engine output is increased:

- Tyres, suspension, brake system and engine cooling system must be adapted to the increase engine output.
- Vehicle must be recertified.
- Report changes in output to the accident insurance body.

This will otherwise lead to the invalidation of the vehicle's general operating permit and its insurance coverage.

If you sell the vehicle, inform the buyer of any alterations to the vehicle's engine output. This may constitute a punishable offence under national legislation.

### Qualified specialist workshop

A qualified specialist workshop has the necessary special skills, tools and qualifications to correctly carry out any necessary work on your vehicle. This particularly applies to work relevant to safety.

Always have the following work on the vehicle carried out at a qualified specialist workshop:

- Safety-relevant works
- Service and maintenance work
- Repair work
- Modifications as well as installations and conversions
- Work on electronic components

Mercedes-Benz recommends that you use a Mercedes-Benz service centre for this purpose.

### Vehicle registration

Mercedes-Benz may ask its service centres to carry out technical inspections on certain vehicles. The quality or safety of the vehicle is improved as a result of the inspection.

Mercedes-Benz can only inform you about vehicle checks if it has your registration data.

In the following cases your vehicle may not be registered to you yet:

- you did not purchase your vehicle at an authorised specialist dealer.
- your vehicle has not yet been inspected at a Mercedes-Benz service centre.

It is advisable to register your vehicle with a Mercedes-Benz service centre.

Inform Mercedes-Benz as soon as possible about any change in address or vehicle ownership. You can do this, for example, at a Mercedes-Benz service centre.

### Correct use of the vehicle

If you remove warning stickers, you or others may fail to recognise the dangers. Leave warning stickers in position.

Observe the following information in particular when operating the vehicle:

- safety notes in these Operating Instructions
- technical data for the vehicle
- traffic rules and regulations
- laws pertaining to motor vehicles and safety standards

**⚠ WARNING** Risk of fire and accident when transporting substances which are hazardous to health or react aggressively

Gases and fluids can even escape from containers which are fully closed.

This can adversely affect your concentration during the journey and your health. Electronic component parts may also experience malfunctions, short circuits or system failures.

▶ Do not stow or transport any substances which are hazardous to health and/or aggressively reactive in the vehicle interior.

Substances that constitute a health hazard or react aggressively include, for example:

- solvents
- fuel
- oil and grease
- cleaning agents
- acid

## Information on the REACH directive

### EU and EFTA countries only:

The REACH directive (Directive (EC) No. 1907/2006, Article 33) stipulates a duty to supply information about substances of very high concern (SVHCs).

Mercedes-Benz AG acts to the best of its knowledge to prevent these SVHCs from being used and to enable customers to safely handle these substances. There are SVHCs known to Mercedes-Benz AG, according to supplier information and internal product information, found in individual components of this vehicle in quantities of over 0.1 percent by weight.

Further information can be obtained at the following addresses:

- <https://reach.daimler.com/de/home/>
- <https://reach.daimler.com/en/home/>

## Notes for persons with electronic medical aids

Mercedes-Benz AG cannot, despite carefully developing vehicle systems, completely rule out the interaction of vehicle systems with electronic medical aids such as cardiac pacemakers.

In addition, there are components built into the vehicle that, regardless of the operating status of your vehicle, can generate magnetic fields on a par with permanent magnets. These fields can be found, for example, in the area around the multimedia and sound system or also in the seating area, depending on the vehicle equipment.

For this reason, the following can occur in isolated cases, depending on the aids used:

- medical aids malfunctioning
- adverse health effects

Observe the notes and warnings of the manufacturer of the medical aids; if in doubt, contact the device manufacturer and/or your doctor. If there is continuing uncertainty concerning the possibility of medical aids malfunctioning, Mercedes-Benz AG recommends using only few electrical vehicle systems and/or maintaining a distance from the components.

Only have repairs and maintenance work in the area of the following components carried out by a qualified specialist workshop:

- vehicle components carrying live voltage
- transmission aerials
- multimedia system and sound system

If you have any queries or suggestions, consult a qualified specialist workshop.

## Implied warranty

**!** **NOTE** Damage to the vehicle arising from violation of these operating instructions.

Damage to the vehicle can arise from violation of these operating instructions.

Such damage is not covered by either the Limited Warranty or the new or used-vehicle warranty.

▶ Observe the instructions in these operating instructions on proper operation of your vehicle as well as regarding possible vehicle damage.

## QR codes for rescue card

The QR code stickers are affixed to the B-pillar on the driver's and front passenger side. In the event of an accident, emergency services can use the QR code to quickly determine the corresponding rescue card for your vehicle. The current rescue card contains the most important information about your vehicle in a compact form, e.g. the routing of the electric lines.

Further information can be obtained at <https://www.mercedes-benz.de/qr-code>

## Data storage

### Data processing in the vehicle

#### Electronic control units

Electronic control units are fitted in your vehicle. Control units process data which, for example, they receive from vehicle sensors, generate themselves or exchange between themselves. Some control units are required for the safe operation of your vehicle, some assist you when driving, such as driver assistance systems, while others enable convenience or infotainment functions.

The following provides you with general information regarding data processing in the vehicle. Additional information regarding exactly which data in your vehicle are collected, saved and transmitted to third parties, and for what purpose, can be found in the information directly related to the functional characteristics in question in their respective operating instructions. This information is also available online and, depending on the vehicle equipment, digitally.

### Personal data

Every vehicle is identified by a unique vehicle identification number. Depending on the country, this vehicle identification number can be used by, for example, governmental authorities to determine the identity of the owner. There are other possibilities for using data collected from the vehicle to identify the owner or driver, such as the licence plate number.

Therefore, data generated or processed by control units may be attributable to a person or, under certain conditions, become attributable to a person. Depending on which vehicle data are available, it may be possible to make inferences about, for example, your driving behaviour, your location, your route or your use patterns.

### Legal requirements regarding the disclosure of data

If legally required to do so, manufacturers are, in individual cases, legally obliged to provide governmental entities, upon request and to the extent required, data stored by the manufacturer. For example, this may be the case during the investigation of a criminal offence.

Governmental entities are themselves, in individual cases and within the applicable legal framework, authorised to read out data from the vehicle. In the case of an accident, information that can help with an investigation can, therefore, be taken from the airbag control unit, for example.

### Operational data in the vehicle

This is data regarding the operation of the vehicle, which have been processed by control units.

This includes the following data, for example:

- vehicle status information such as the speed, longitudinal acceleration, lateral acceleration, number of wheel revolutions or the fastened seat belts display
- ambient conditions, such as temperature, rain sensor or distance sensor

Generally, these are volatile data and will not be stored beyond the period of operation but will only be processed within the vehicle itself. Control units, vehicle keys for example, often contain data memories. Their use permits the temporary or permanent documentation of technical information about the vehicle's operating state, component loads, maintenance requirements and technical events or faults.

Depending on the technical equipment, the following data are stored:

- operating status of system components, such as fill levels, tyre pressure or battery status
- malfunctions or faults in important system components, such as lights or brakes
- system reactions in special driving situations, such as airbag deployment or the intervention of stability control systems
- information on events in which the vehicle is damaged

In certain cases, it may be required to store data that would have otherwise been temporary. This may be the case if the vehicle has detected a malfunction, for example.

If you use services such as repair services and maintenance work, stored operational data as well as the vehicle identification number can be read out and used. They can be read out by service network employees, such as workshops and manufacturers or third parties, such as breakdown services. The same is true in the case of warranty claims and quality assurance measures.

In general, the readout is performed via the legally prescribed port for the diagnostics connection in the vehicle. The operational data that are read out document technical states of the vehicle or of individual components and assist in the diagnosis of malfunctions, compliance with warranty obligations and quality improvement. To that end, these data, in particular information about component loads, technical events, malfunctions and other faults may be transmitted along with the vehicle identification number to the manufacturer. In addition, the manufacturer is subject to product liability. For this reason, the manufacturer also uses operational data from the vehicle, for example, for recalls. These data can also be used to examine the customer's warranty and guarantee claims.

Fault memories in the vehicle can be reset by a service outlet or at your request as part of repair or maintenance work.

### Convenience and infotainment functions

You can store convenience settings and individual settings in the vehicle and change or reset them at any time.

Depending on the vehicle equipment, this includes the following settings, for example:

- seat and steering wheel positions
- suspension and climate control settings
- individual settings, such as interior lighting

Depending on the selected equipment, you can import data into vehicle infotainment functions yourself.

Depending on the vehicle equipment, this includes the following data, for example:

- multimedia data, such as music, films or photos for playback in an integrated multimedia system
- address book data for use in an integrated hands-free system or an integrated navigation system
- entered navigation destinations
- data on the use of Internet services

These data for convenience and infotainment functions may be saved locally in the vehicle or they may be located on a device which you have connected to the vehicle, such as a smartphone, USB flash drive or MP3 player. If you have entered these data yourself, you can delete them at any time.

These data are transmitted from the vehicle to third parties only at your request. This applies, in particular, when you use online services in accordance with the settings that you have selected.

### Smartphone integration (e.g. Android Auto or Apple CarPlay®)

If your vehicle is equipped appropriately, you can connect your smartphone or another mobile end device to the vehicle. You can then control them by means of the control elements integrated in the vehicle. The smartphone's picture and sound can be output via the multimedia system. Simultaneously, specific items of information are transferred to your smartphone. Depending on the type of integration, this includes position data, day/night mode and other general vehicle statuses. For more information, please consult the vehicle/infotainment Operating Instructions.

This integration allows the use of selected smartphone apps, such as navigation or music player apps. There is no additional interaction between

the smartphone and the vehicle, particularly active access to vehicle data. The type of additional data processing is determined by the provider of the app being used. Which settings you can make, if any, depends on the specific app and the operating system of your smartphone.

---

### Online services

#### Wireless network connection

If your vehicle has a wireless network connection, data can be exchanged between your vehicle and other systems. The wireless network connection is made possible by the vehicle's own transmitter and receiver or by a mobile end device that you have brought into the vehicle, for example, a smartphone. Online functions can be used via this wireless network connection. This includes online services and applications/apps provided to you by the manufacturer or by other providers.

#### Manufacturer's own services

Regarding the manufacturer's online services, the individual functions are described by the manufacturer in a suitable place, for example, in the Operating Instructions or on the manufacturer's website, where the relevant data protection information is also given. Personal identification data may be used to provide online services. Data is exchanged via a secure connection, e.g. the manufacturer's designated IT systems. Any personal data which are collected, processed and used, other than for the provision of services, is done so exclusively on the basis of legal permission. This is the case, for example, for a legally prescribed emergency call system, a contractual agreement or when consent has been given.

You can have services and functions, some of which are subject to a fee, activated or deactivated. This excludes legally prescribed functions and services, such as an emergency call system.

#### Services of third parties

If you use online services from other providers (third parties), these services are the responsibility of the provider in question and subject to that provider's data protection conditions and terms of use. As a general rule, the manufacturer has no influence on the content exchanged.

For this reason, when services are provided by third parties, please ask the service provider in question for information about the type, extent and purpose of the collection and use of personal data.

## Onboard Logic Unit (OLU)

The Onboard Logic Unit (OLU) is available to commercial customers.

It contains control units, including aerials for connection via wireless networks, that permit the exchange of data between your vehicle and other systems. The control units can be used in conjunction with service provided by a third party. Under certain circumstances, these services may alter the basic configuration of the vehicle and could affect the performance of certain vehicle functions.

For further information about specific services, read the operating instructions of the third-party provider. For further information about the Onboard Logic Unit, consult a Mercedes-Benz Service Centre.

If you, yourself, do not own and are not responsible for the vehicle, you may not know the current status of the Onboard Logic Unit. For further information concerning the services which are currently active, including any data which may be being processed as defined by the GDPR, please contact the person responsible for the vehicle.

## Data protection rights

Depending on your country or the equipment and range of functions of your vehicle as well as the services you use and the services on offer, you are entitled to different data protection rights. Further information on data protection and your data protection rights can either be found on the manufacturer's website or you will receive this information as part of the various services and service offers. There, you will also find the contact information for the manufacturer and its data protection officer.

At a workshop, for example, with the support of a specialist and possibly for a fee, you can have data read out which is stored only locally in the vehicle.

## Copyright

Information on licences for free and open-source software used in your vehicle is available along with updates online at:

<https://www.mercedes-benz.com/opensource>.

## Restraint system

### Protection provided by the restraint system

The restraint system includes the following components:

- Seat belt system
- Airbags
- Child restraint system
- Child seat securing systems

The restraint system can help prevent the vehicle occupants from coming into contact with parts of the vehicle interior in the event of an accident. In the event of an accident, the restraint system can also reduce the forces to which the vehicle occupants are subjected.

Only a seat belt which is worn correctly can provide the intended level of protection. Depending on the detected accident situation, seat belt tensioners and/or airbags supplement the protection offered by a correctly worn seat belt. Seat belt tensioners and/or airbags are not deployed in every accident.

In order for the restraint system to provide the intended level of protection, each vehicle occupant must observe the following information:

- Fasten seat belts correctly.
- Sit in an almost upright seat position with their back against the seat backrest.
- Sit with their feet resting on the floor, if possible.
- Always secure persons under 1.50 m tall in an additional restraint system suitable for Mercedes-Benz vehicles.

However, no system available today can completely eliminate injuries and fatalities in every accident situation. In particular, the seat belt and airbag generally do not protect against objects penetrating the vehicle from the outside. It is also not possible to completely rule out the risk of injury caused by the airbag deploying.

### Limitations of the protection provided by the restraint system

**⚠ WARNING** Risk of injury or death due to modifications to the restraint system

Vehicle occupants may no longer be protected as intended if alterations are made to the restraint system.

- ▶ Never alter the parts of the restraint system.
- ▶ Never tamper with the wiring or any electronic component parts or their software.

If it is necessary to adjust the vehicle to accommodate a person with disabilities, contact a qualified specialist workshop.



Mercedes-Benz recommends that you only use driving aids which have been approved specifically for your vehicle by Mercedes-Benz.

### Restraint system functionality

When the vehicle is switched on, a self-test is performed, during which the  restraint system warning lamp lights up. It goes out no later than a few seconds after the vehicle is started. The components of the restraint system are then functional.

### Restraint system malfunction

A malfunction has occurred in the restraint system in the following cases:

- The  restraint system warning lamp does not light up when the vehicle is switched on.
- The  restraint system warning lamp lights up continuously or repeatedly during a journey.

**⚠ WARNING** Risk of injury due to malfunctions in the restraint system

Components in the restraint system may be activated unintentionally or not deploy as intended in an accident.

- ▶ Have the restraint system checked and repaired immediately at a qualified specialist workshop.

### Function of the restraint system in an accident

How the restraint system works is determined by the severity of the impact detected and the type of accident anticipated:

- frontal impact
- rear impact
- side impact
- only if the vehicle is equipped with side airbag or window airbag: overturning or rollover

The activation thresholds for the components of the restraint system are determined based on the evaluation of the sensor values measured at various points in the vehicle. This process is pre-emptive in nature. The triggering/deployment of the components of the restraint system should take place in good time at the start of the collision.

Factors which can only be seen and measured after a collision has occurred cannot play a decisive role in airbag deployment. Nor do they provide an indication of airbag deployment.

The vehicle may be deformed significantly without an airbag being deployed. This is the case if only parts which are relatively easily deformed are affected and the rate of vehicle deceleration is not high. Conversely, an airbag may be deployed even though the vehicle suffers only minor deformation. If very rigid vehicle parts, such as longitudinal members, are hit, the vehicle deceleration may be high enough for this to happen.

Depending on the detected deployment situation, the components of the restraint system can be activated or deployed independently of each other:

- Seat belt tensioner: frontal impact, rear impact, side impact<sup>1)</sup>, overturning<sup>1)</sup>, rollover<sup>1)</sup>
- Driver's airbag, front passenger airbag: frontal impact
- Side airbag: side impact
- Window airbag: side impact, overturning, rollover, frontal impact

<sup>1)</sup> Only when the vehicle is fitted with a side airbag or window airbag.

The co-driver airbag can only be deployed in the event of an accident if the PASSENGER AIR BAG OFF indicator lamp is off. If the co-driver seat is occupied, make sure, both before and during the journey, that the status of the co-driver airbag is correct (→ page 37).

#### **⚠ WARNING** Risk of burns from hot airbag components

The airbag parts are hot after an airbag has been deployed.

- ▶ Do not touch the airbag parts.
- ▶ Have a deployed airbag replaced at a qualified specialist workshop as soon as possible.

Mercedes-Benz recommends that you have the vehicle towed to a qualified specialist workshop after an accident. Take this into account, particu-

larly if a seat belt tensioner is triggered or an airbag deployed.

If the seat belt tensioners are triggered or an airbag is deployed, you will hear a bang, and a small amount of powder may also be released:

- the bang will not generally affect your hearing.
- in general, the powder released is not hazardous to health but may cause short-term breathing difficulties to persons suffering from asthma or other pulmonary conditions.

Provided it is safe to do so, leave the vehicle immediately or open the window in order to prevent breathing difficulties.

## Seat belts

### Protection provided by the seat belt

Always fasten your seat belt correctly before starting a journey. Only a seat belt which is worn correctly can provide the intended level of protection.

#### **⚠ WARNING** Risk of injury or death due to incorrectly fastened seat belt

If the seat belt is not worn correctly, it cannot perform its intended protective function.

In addition, an incorrectly fastened seat belt can also cause injuries, for example, in the event of an accident or when braking or changing direction suddenly.

- ▶ Always ensure that all vehicle occupants have their seat belts fastened correctly and are sitting properly.

Always observe the instructions about the correct driver's seat position and adjusting the seat (→ page 72).

In order for the correctly worn seat belt to provide the intended level of protection, each vehicle occupant must observe the following information:

- The seat belt must not be twisted and must fit tightly and snugly across the body.
- The seat belt must be routed across the centre of the shoulder and as low down across the hips as possible.
- The shoulder section of the seat belt should not touch your neck nor be routed under your arm or behind your back.
- Avoid wearing bulky clothing, e.g. a winter coat.

- Push the lap belt down as far as possible across your hips and pull tight with the shoulder section of the belt. Never route the lap belt across your abdomen.

Pregnant women must also take particular care with this.

- Never route the seat belt across sharp, pointed, abrasive or fragile objects.
- Only one person should use each seat belt at any one time.
- Never secure objects with a seat belt if the seat belt is being used by one of the vehicle's occupants.

Also ensure that no objects, e.g. a cushion, are ever placed between a person and the seat.

If children are travelling in the vehicle, always observe the instructions and safety notes on "Children in the vehicle" (→ page 40).

Always observe the instructions for loading the vehicle when securing objects, luggage or loads (→ page 217).

### Limitations of the protection provided by the seat belt

#### **⚠ WARNING** Risk of injury or death due to incorrect seat position

The seat belt will not offer the intended level of protection if you have not moved the seat backrest to an almost vertical position.

In particular, you may slip under the seatbelt and injure yourself.

- ▶ Adjust the seat properly before beginning your journey.
- ▶ Always ensure that the seat backrest is in an almost vertical position and that the shoulder section of your seat belt is routed across the centre of your shoulder.

#### **⚠ WARNING** Risk of injury or death when additional restraint systems are not used for persons with a smaller stature

Persons under 1.50 m tall cannot wear the seat belt correctly without a suitable additional restraint system.

- ▶ Always secure persons under 1.50 m tall in a suitable restraint system.

#### **⚠ WARNING** Risk of injury or death due to damaged or modified seat belts

Seat belts cannot provide protection in the following situations:

- the seat belt is damaged, has been modified, is extremely dirty, bleached or dyed
- the seat belt buckle is damaged or extremely dirty
- modifications have been made to the seat belt tensioner, seat belt anchorage or seat belt retractor

Seat belts may sustain non-visible damage in an accident, e.g. due to glass splinters.

Modified or damaged seat belts could tear or fail in the event of an accident, for example.

Modified seat belt tensioners could accidentally trigger or fail to function as intended.

- ▶ Never modify the seat belt system, for example the seat belt, seat belt buckle, seat belt tensioner, seat belt anchorage and seat belt retractor.
- ▶ Make sure that the seat belts are undamaged, not worn and clean.
- ▶ Always have the seat belts checked immediately after an accident at a qualified specialist workshop.

Mercedes-Benz recommends that you use seat belts which have been approved for your vehicle by Mercedes-Benz.

#### **⚠ WARNING** Risk of injury or death from deployed pyrotechnic seat belt tensioners

Pyrotechnic seat belt tensioners that have been deployed are no longer operational and are unable to perform their intended protective function.

- ▶ Therefore, have deployed pyrotechnic seat belt tensioners immediately replaced at a qualified specialist workshop.

Mercedes-Benz recommends that you have the vehicle towed to a qualified specialist workshop after an accident.

**!** **NOTE** Damage caused by trapping the seat belt

If an unused seat belt is not fully retracted, it may become trapped in the door or in the seat mechanism.

- ▶ Always ensure that an unused seat belt is fully retracted.

### Fastening and adjusting seat belts

If the seat belt is pulled quickly or sharply, the seat belt retractor locks. The seat belt strap cannot be pulled out any further.

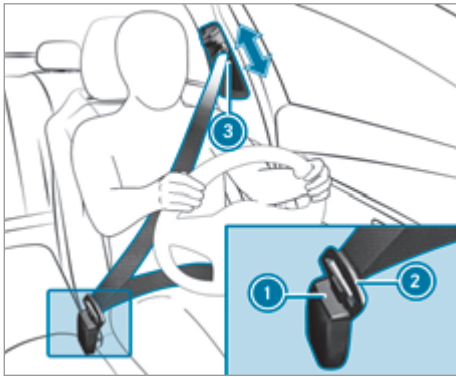

- ▶ Always engage seat belt tongue **2** of the seat belt into seat belt buckle **1** of the corresponding seat.
  - ▶ Press and hold the seat belt outlet release and slide seat belt outlet **3** into the desired position.
  - ▶ Let go of the seat belt outlet release and ensure that seat belt outlet **3** locks into position.
- i** Only a seat belt which is worn correctly can provide the intended level of protection. Observe the notes on fastening the seatbelt (→ page 31).

**!** **NOTE** Deployment of components of the restraint system when the front passenger seat is unoccupied and a seat belt is buckled

When the front passenger seat is unoccupied and the seat belt tongue of the seat belt is engaged in the seat belt buckle, components of the restraint system may deploy unnecessa-

rily on the front passenger side, e.g. the seat belt tensioner.

- ▶ Only buckle the seat belts as intended.

- i** Observe the notes on stowage areas (→ page 217). Information on fitting a child restraint system and on children travelling in the vehicle can be found in the "Children in the vehicle" section (→ page 42).

### Seat belt adjustment function

**Vehicles with PRE-SAFE®:** after a front seat belt has been fastened, the automatic seat belt adjustment may apply a certain tightening force. Do not hold onto the seat belt while it is adjusting.

You can activate and deactivate the seat belt adjustment function using the multimedia system (→ page 33).

### Activating or deactivating the seat belt adjustment using the multimedia system

Multimedia system:

→ ▶ Settings ▶ Vehicle

- ▶ Activate or deactivate Belt adjustment.

### Releasing the seat belts

- ▶ Press the release button in the seat belt buckle and guide the seat belt back with the seat belt tongue.

### Function of the seat belt warning system for driver and co-driver

The seat belt warning lamp in the Instrument Display is a reminder that all vehicle occupants must wear their seat belts correctly.

A warning tone may also sound.

The seat belt warning goes out when the driver and co-driver fasten their seat belts.

Only for certain countries: regardless of whether the driver's and co-driver's seat belts are already fastened, the seat belt warning lamp lights up for six seconds every time the vehicle is switched on. After the vehicle is started, it goes out as soon as the driver's and the co-driver's seat belts have been fastened.

## Airbags

### Overview of airbags

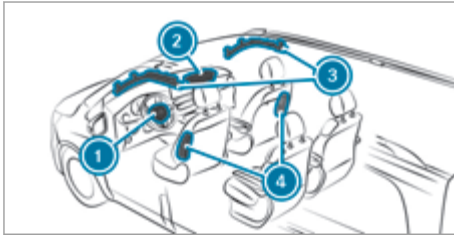

Example: vehicles with window airbag above front door

- ① Driver's airbag
- ② Co-driver airbag
- ③ Window airbag
- ④ Side airbag

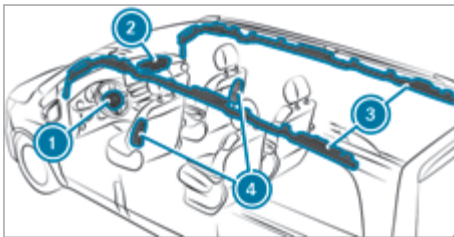

Example: vehicles with window airbag for all rows of seats

- ① Driver's airbag
- ② Co-driver airbag
- ③ Window airbag
- ④ Side airbag

An airbag's installation location is identified by the label AIRBAG.

When enabled, an airbag can provide additional protection for the respective vehicle occupant.

Possible protection per airbag:

- Driver's airbag, co-driver airbag: head and ribcage
- Window airbag: head
- Side airbag: ribcage and pelvis

**⚠ WARNING** Risk of injury or death if the co-driver airbag is enabled

If the co-driver airbag is enabled, a child on the co-driver seat may be struck by the co-driver airbag during an accident.

NEVER use a rearward-facing child restraint system on a seat with an ENABLED FRONT AIRBAG; DEATH or SERIOUS INJURY to the CHILD can occur.

When fitting a child restraint system to the co-driver seat, observe the vehicle-specific information (→ page 49). Also be sure to observe the notes on rearward-facing or forward-facing child restraint systems on the co-driver seat.

#### Information on the automatic co-driver airbag shut-off

The co-driver airbag can only be deployed in the event of an accident if the PASSENGER AIR BAG OFF indicator lamp is off. If the co-driver seat is occupied, make sure, both before and during the journey, that the status of the co-driver airbag is correct (→ page 37).

**!** **NOTE** Deployment of components of the restraint system when the front passenger seat is unoccupied

In an accident, the components of the restraint system may deploy unnecessarily on the front passenger side if:

- There are heavy objects on the front passenger seat.
- The seat belt tongue is engaged in the seat belt buckle of the front passenger seat and the front passenger seat is unoccupied.

▶ Stow objects in a suitable place.

▶ Only one person should use each seat belt at any one time.

### Protection provided by the airbags

Depending on the accident situation, an airbag may supplement the protection offered by a correctly fastened seat belt.

**⚠ WARNING** Risk of injury or death due to an incorrect seat position

If you deviate from the correct seat position, the airbag cannot perform its intended protective function.

Each vehicle occupant must make sure of the following:

- Fasten seat belts correctly. Pregnant women must take particular care to ensure

that the lap belt never lies across the abdomen.

- Adopt the correct seat position and keep as far away as possible from the airbags.
  - Observe the following information.
- ▶ Always make sure that there are no objects between the airbag and vehicle occupant.

To avoid the risks resulting from the deployment of an airbag, each vehicle occupant must observe the following information in particular:

- Before starting your journey, adjust your seat correctly; both the driver's and co-driver seat should be moved as far back as possible.

When doing so, always observe the information on the correct driver's seat position (→ page 72).

- Only hold the steering wheel by the steering wheel rim. This allows the airbag to be fully deployed.
- Always lean against the seat backrest when the vehicle is in motion. Do not lean forwards or against the door or side window. You may otherwise be in the deployment area of the airbags.
- Always keep your feet on the floor. Do not put your feet on the cockpit, for example. Your feet may otherwise be in the deployment area of the airbag.
- If children are travelling in the vehicle, observe the additional notes (→ page 40).
- Always stow and secure objects correctly.

Objects in the vehicle interior may prevent an airbag from functioning correctly. Each vehicle occupant must always make sure of the following in particular:

- There are no people, animals or objects between the vehicle occupants and an airbag.
- There are no objects between the seat, door and door pillar (B-pillar).
- There are no hard objects, e.g. coat hangers, hanging on the grab handles or coat hooks.
- There are no accessories, such as mobile navigation devices, mobile phones or cup holders, within the deployment area of an airbag, e.g. on the cockpit, on the door, on the side window or on the side trim.

In addition, no connecting cables, tensioning straps or retaining straps must be routed or attached to the vehicle within the deployment area of an airbag. Always comply with the accessory manufacturer's installation instructions and, in particular, the notes on suitable places for installation.

- There are no heavy, sharp-edged or fragile objects in the pockets of your clothing. Store such objects in a suitable place.

### Limitations of the protection provided by airbags

**⚠ WARNING** Risk of injury due to modifications to the cover of an airbag

If you modify the cover of an airbag or affix objects such as stickers to it, the airbag can no longer function as intended.

- ▶ Never modify the cover of an airbag.
- ▶ Do not attach any objects to the cover.

An airbag's installation location is identified by the label AIRBAG (→ page 34).

Objects in the deployment area of an airbag may prevent the airbag from functioning correctly.

**⚠ WARNING** Risk of injury from objects in the deployment area of an airbag

Objects in the deployment area of an airbag can hinder or prevent the correct deployment of the airbag.

The airbag may then deploy in an uncontrolled manner and may even cause additional injuries to the vehicle occupants by deploying. This may be the case in particular if the airbag is integrated into the seat.

- ▶ Always stow and secure objects correctly.
- ▶ Before commencing your journey, make sure that no objects are stowed in the deployment area of an airbag.

**⚠ WARNING** Risk of injury or death due to the use of unsuitable seat covers

Due to unsuitable seat covers, the airbags cannot protect vehicle occupants as intended.

In addition, the operation of the automatic front passenger airbag shutoff could be restricted.

- ▶ You should only use seat covers that have been approved for the corresponding seats by Mercedes-Benz.

### Vehicles with window airbags in all rows of seats:

#### **⚠ WARNING** Risk of injury due to malfunctioning sensors in the door

The function of the airbags can be impaired due to modifications or incorrect work performed on the doors or door trim, or if the doors are damaged.

- ▶ Never modify the doors or parts of the doors.
- ▶ Always have work on the doors or door trim carried out at a qualified specialist workshop.

#### **⚠ WARNING** Risk of injury due to deployed airbag

A deployed airbag no longer offers any protection.

- ▶ Have the vehicle towed to a qualified specialist workshop in order to have the deployed airbag replaced.

Have deployed airbags replaced immediately.

### Status of the co-driver airbag

#### Function of the automatic co-driver airbag shutoff

The automatic co-driver airbag shutoff is able to detect whether the co-driver seat is occupied by a person or a child restraint system. The co-driver airbag is enabled or disabled accordingly.

#### **⚠ WARNING** Risk of injury or death due to objects under the co-driver seat

Objects trapped under the co-driver seat can interfere with the function of the automatic co-driver airbag shutoff or damage the system.

- ▶ Do not store any objects under the co-driver seat.
- ▶ When the co-driver seat is occupied, make sure that no objects are trapped under the co-driver seat.

When fitting a child restraint system to the co-driver seat, observe the vehicle-specific information (→ page 49). Also be sure to observe the notes on rearward-facing or forward-facing child

restraint systems on the co-driver seat (→ page 49).

#### **⚠ WARNING** Risk of injury or death due to objects between the seat surface and the child restraint system

Objects between the sitting surface and the child restraint system could affect the function of the automatic co-driver airbag shutoff.

- ▶ Do not place any objects between the sitting surface and the child restraint system.
- ▶ Make sure that the entire base of the child restraint system is resting on the sitting surface of the co-driver seat.
- ▶ Make sure that the backrest of the forward-facing child restraint system is, as far as possible, resting on the seat backrest of the co-driver seat.
- ▶ Always comply with the child restraint system manufacturer's installation instructions.

A person on the co-driver seat must observe the following information:

- Fasten seat belts correctly (→ page 31).
- Sit in an almost upright seat position with their back against the seat backrest.
- Sit with their feet resting on the floor, if possible.

The co-driver airbag may otherwise be disabled by mistake, for example, in the following situations:

- The co-driver transfers their weight by supporting themselves on a vehicle armrest.
- The co-driver sits in such a way that their weight is raised from the seat surface.

#### **⚠ WARNING** Risk of injury or death due to a disabled front passenger airbag

The front passenger airbag is disabled when the PASSENGER AIR BAG OFF indicator lamp is lit.

A person in the front passenger seat could then, for example, come into contact with the vehicle interior, especially if the person is sitting too close to the cockpit.

If the front passenger seat is occupied, always ensure that:

- the classification of the person in the front passenger seat is correct and the front passenger airbag is enabled or disabled in accordance with the person in the front passenger seat.
  - the front passenger seat has been moved as far back as possible.
  - the person is seated correctly.
- ▶ Both before and during the journey, ensure that the status of the front passenger airbag is correct.

If the co-driver seat is occupied, the classification of the person or child restraint system on the co-driver seat takes place after the co-driver airbag shutoff self-test. The PASSENGER AIR BAG OFF indicator lamp displays the status of the co-driver airbag.

Always observe the notes on the function of the PASSENGER AIR BAG OFF indicator lamp (→ page 37).

### Function of the PASSENGER AIR BAG indicator lamp

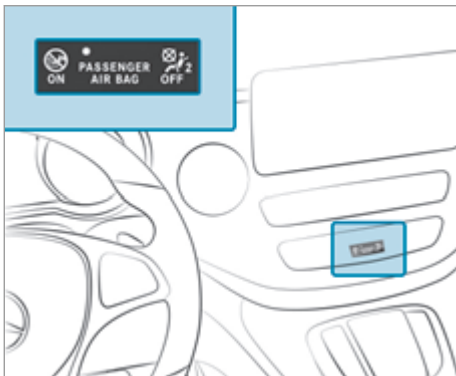

The PASSENGER AIR BAG ON indicator lamp is inoperative. When the vehicle is switched on, it lights up briefly and then goes out again. Only the PASSENGER AIR BAG OFF indicator lamp displays the status of the co-driver airbag. The PASSENGER AIR BAG OFF indicator lamp may be lit continuously or be off.

Vehicles without an automatic co-driver airbag shutoff have a special sticker affixed to the side of the cockpit on the co-driver side (→ page 48).

### Self-test of automatic co-driver airbag shutoff

When the vehicle is switched on, a self-test is performed during which the PASSENGER AIR BAG OFF indicator lamp lights up for approximately six seconds.

The status of the co-driver airbag is displayed after the self-test:

- PASSENGER AIR BAG OFF is not lit: the co-driver airbag may deploy during an accident.
- PASSENGER AIR BAG OFF lights up continuously: the co-driver airbag is disabled. It will not be deployed in the event of an accident.

If the PASSENGER AIR BAG OFF indicator lamp and the  restraint system warning lamp light up simultaneously, the co-driver seat may not be used. Also in this case, do not fit a child restraint system to the co-driver seat. Have the automatic co-driver airbag shutoff checked and repaired immediately at a qualified specialist workshop.

### Status indicator

If the co-driver seat is occupied, ensure, both before and during the journey, that the status of the co-driver airbag is correct for the current situation.

**After fitting a rearward-facing child restraint system to the co-driver seat:** PASSENGER AIR BAG OFF must be lit continuously.

**⚠ WARNING** Risk of injury or death when using a rearward-facing child restraint system while the front passenger airbag is enabled

If you secure a child in a rearward-facing child restraint system on the front passenger seat and the PASSENGER AIR BAG OFF indicator lamp is off, the front passenger airbag can deploy in the event of an accident.

The child could be struck by the airbag.

- ▶ Always ensure that the front passenger airbag is disabled. The PASSENGER AIR BAG OFF indicator lamp must be lit.
- ▶ NEVER use a rearward-facing child restraint system on a seat with an ENABLED FRONT AIRBAG. This can result in the DEATH of or SERIOUS INJURY to the CHILD.

When fitting a child restraint system to the co-driver seat, observe the vehicle-specific information (→ page 49).

Depending on the child restraint system and the stature of the child, the PASSENGER AIR BAG OFF indicator lamp may be off. In this case, do not fit the rearward-facing child restraint system to the co-driver seat.

Instead, fit the rearward-facing child restraint system to a suitable rear seat.

**After fitting a forward-facing child restraint system to the co-driver seat:** depending on the child restraint system and the stature of the child, PASSENGER AIR BAG OFF may be lit continuously or be off. Always observe the following information.

**⚠ WARNING** Risk of injury or death due to incorrect positioning of the forward-facing child restraint system

If you secure a child in a forward-facing child restraint system on the front passenger seat that is positioned too close to the cockpit, in the event of an accident, the child could:

- come into contact with the vehicle interior if the PASSENGER AIR BAG OFF indicator lamp is lit, for example
- be struck by the airbag if the PASSENGER AIR BAG OFF indicator lamp is off.

▶ Always move the front passenger seat as far back as possible and fully retract the seat cushion length adjustment. While doing so, always make sure that the shoulder belt strap is correctly routed from the seat belt outlet of the vehicle to the shoulder belt guide on the child restraint system. The shoulder belt strap must be routed forwards and downwards from the seat belt outlet. If necessary, adjust the seat belt outlet and the front passenger seat accordingly.

▶ Always comply with the child restraint system manufacturer's installation instructions.

When fitting a child restraint system to the co-driver seat, observe the vehicle-specific information (→ page 49).

**If a person is sitting on the co-driver seat:** PASSENGER AIR BAG OFF may be lit continuously or be off, depending on the person's stature.

A person on the co-driver seat must always observe the following information:

- If the co-driver seat is occupied by an adult or a person with a stature corresponding to that of an adult, the PASSENGER AIR BAG OFF indicator lamp must be off. This indicates that the co-driver airbag is enabled.

If the PASSENGER AIR BAG OFF indicator lamp is lit continuously, an adult or person with a build corresponding to that of an adult should not use the co-driver seat.

Instead, they should use a rear seat.

- If the co-driver seat is occupied by a person of smaller stature (e.g. a teenager or small adult), the PASSENGER AIR BAG OFF indicator lamp either lights up continuously or remains off, depending on the result of the classification.
  - If the PASSENGER AIR BAG OFF indicator lamp is off: move the co-driver seat as far back as possible, or the person of smaller stature should use a rear seat.
  - If the PASSENGER AIR BAG OFF indicator lamp is lit continuously: the person of smaller stature should not use the co-driver seat.

**⚠ WARNING** Risk of injury or death when the PASSENGER AIR BAG OFF indicator lamp is lit

If the PASSENGER AIR BAG OFF indicator lamp remains lit after the self-test, the front passenger airbag is disabled.

If the front passenger seat is occupied, always ensure that:

- The classification of the person in the front passenger seat is correct and the front passenger airbag is enabled or disabled in accordance with the person in the front passenger seat.
- The person is seated properly with a correctly fastened seat belt.
- The front passenger seat has been moved as far back as possible.

Be sure to also observe the following further related subjects:

- Child restraint system on the co-driver seat (→ page 49)
- Suitable positioning of the child restraint system (→ page 42)

## PRE-SAFE® System

### Function of PRE-SAFE® (anticipatory occupant protection)

PRE-SAFE® can detect certain hazardous situations and take pre-emptive measures to protect the vehicle occupants.

PRE-SAFE® can implement the following measures independently of each other:

- Tightening the seat belts on the driver's seat and co-driver seat.
- Closing the side windows.
- **Vehicles with a sliding sunroof:** closing the sliding sunroof.
- **Vehicles with memory function:** adjusting the co-driver seat to a more favourable seat position.

**!** **NOTE** Damage caused by objects in the footwell or behind the seat

The automatic adjustment of the seat position may result in damage to the seat and/or the object.

► Stow objects in a suitable place.

### Reversing the PRE-SAFE® system measures

If an accident did not occur, the pre-emptive measures that were taken are reversed.

You will need to make certain adjustments yourself.

- If the seat belt pre-tensioning is not reduced, move the seat backrest back slightly. The locking mechanism releases.

### Automatic measures after an accident

Depending on the type and severity of the accident, and depending on the vehicle's equipment, the following measures can be implemented, for example:

- activating the hazard warning lights
- triggering an automatic emergency call (→ page 239)
- switching off engine

To start the vehicle again, switch the vehicle off and on once more (→ page 138). Depending on the type and severity of the accident, it

may be possible that the vehicle can no longer be started.

- switching off the fuel supply
- unlocking the vehicle doors
- lowering the front side windows
- switching on the interior lighting

## Safely transporting children in the vehicle

### Always observe when children are travelling in the vehicle

- ⓘ Always observe the safety notes relevant to the situation. In doing so, you will be able to identify possible risks and avoid dangers when children are travelling in the vehicle (→ page 40).

### Be diligent

Bear in mind that negligence when securing a child in the child restraint system may have serious consequences. Always be diligent and secure a child carefully before each journey.

Infants and children must never travel sitting on the lap of a vehicle occupant.

To improve protection for children younger than 12 years old or under 1.50 m in height, Mercedes-Benz recommends you observe the following information:

- Always secure the child in a child restraint system suitable for this Mercedes-Benz vehicle.
- The child restraint system must be appropriate to the age, weight and size of the child.
- The vehicle seat must be suitable for fitting a child restraint system (→ page 42).

Accident statistics show that children secured on the rear seats are generally safer than children secured on the front seats. For this reason, Mercedes-Benz strongly advises that you fit a child restraint system to a rear seat.

### The generic term child restraint system

The generic term child restraint system is used in this set of Operating Instructions. A child restraint system is, for example:

- a baby car seat
- a rearward-facing child seat
- a forward-facing child seat
- a child booster seat with a backrest and seat belt guides

The child restraint system must be appropriate to the age, weight and size of the child.

### Observe laws and regulations

Always observe the legal requirements when using a child restraint system in the vehicle.

Make sure that the child restraint system is approved in accordance with the valid test specifications and guidelines. You can obtain further information at a qualified specialist workshop. Mercedes-Benz recommends that you use a Mercedes-Benz Service Centre for this purpose.

### Only use approved child restraint systems

Only child restraint systems with the UNECE standard UN-R44 are approved for use in the vehicle.

Information on child restraint system approval categories and details on the approval label on the child restraint system (→ page 42).

## Detecting risks, avoiding danger

### Securing systems for child restraint systems in the vehicle

Only use the following securing systems for child restraint systems:

- the ISOFIX securing rings
- the seat belt system of the vehicle
- the Top Tether anchorages

Fitting an ISOFIX child restraint system is preferred.

Simply attaching to the securing rings on the vehicle can reduce the risk of fitting the child restraint system incorrectly.

When securing a child with the integrated seat belt of the ISOFIX child restraint system, always comply with the permissible gross weight for the child and child restraint system (→ page 45).

### Advantage of a rearward-facing child restraint system

It is preferable to transport a baby or a small child in a suitable rearward-facing child restraint system. In this case, the child sits in the opposite direction to the direction of travel and faces backwards.

Babies and small children have comparatively weak neck muscles in relation to the size and weight of their head. The risk of injury to the cervical spine during an accident can be reduced in a rearward-facing child restraint system.

### Always secure a child restraint system correctly

**⚠ WARNING** Risk of injury or death due to incorrect installation of the child restraint system

The child can then not be protected or restrained as intended.

- ▶ Be sure to comply with the manufacturer's installation instructions for the child restraint system and its correct use.
- ▶ Make sure that the entire base of the child restraint system always rests on the sitting surface of the seat.
- ▶ Never place objects (e.g. cushions) under or behind the child restraint system.
- ▶ Use child restraint systems only with the original cover designed for them.
- ▶ Always replace damaged covers with genuine covers.

**⚠ WARNING** Risk of injury or death due to unsecured child restraint systems in the vehicle

If the child restraint system is incorrectly fitted or not secured, it can come loose.

The child restraint system could be flung around and hit vehicle occupants.

- ▶ Always install child restraint systems correctly, even when not in use.
- ▶ Always comply with the child restraint system manufacturer's installation instructions.

- Always observe the child restraint system manufacturer's installation and operating instructions as well as the vehicle-specific information:

- Fitting the ISOFIX child restraint system on the rear seat (→ page 45).
- Securing the child restraint system with the seat belt on the rear seat (→ page 48).
- Securing the child restraint system with the seat belt on the co-driver seat (→ page 49). Observe the specific instructions for the rearward-facing and forward-facing child restraint systems (→ page 49).

If the co-driver seat is occupied, ensure, both before and during the journey, that

the status of the co-driver airbag is correct for the current situation (→ page 37).

- Observe the warning labels in the vehicle interior and on the child restraint system.
- Also secure Top Tether if present.

### Do not modify the child restraint system

**⚠ WARNING** Risk of injury due to modifications to the child restraint system

The child restraint system can no longer function properly. This poses an increased risk of injury.

- ▶ Never modify a child restraint system.
- ▶ Only affix accessories which have been specially approved for this child restraint system by the child restraint system's manufacturer.

Mercedes-Benz recommends Mercedes-Benz care products for cleaning child restraint systems recommended by Mercedes-Benz.

### Only use child restraint systems which are in proper working condition

**⚠ WARNING** Risk of injury or death caused by the use of damaged child restraint systems

Child restraint systems or their retaining systems that have been subjected to stress in an accident may not be able to perform their intended protective function.

It may be the case that the child cannot be properly restrained.

- ▶ Always immediately replace child restraint systems that have been damaged or involved in an accident.
- ▶ Have the securing systems for the child restraint systems checked at a qualified specialist workshop before installing a child restraint system again.

### Avoid direct sunlight

**⚠ WARNING** Risk of burns when the child seat is exposed to direct sunlight

If the child restraint system is exposed to direct sunlight or heat, parts could heat up. Children could suffer burns from these parts, particularly on metallic parts of the child restraint system.

- ▶ Always make sure that the child restraint system is not exposed to direct sunlight.
- ▶ Protect the child restraint system with a blanket, for example.
- ▶ If the child restraint system has been exposed to direct sunlight, allow it to cool before securing a child into it.
- ▶ Never leave children unattended in the vehicle.

### Observe when stopping or parking

**⚠ WARNING** Risk of accident and injury due to leaving children unattended in the vehicle

If children are left unattended in the vehicle, they could, in particular:

- open doors, thereby endangering other persons or road users.
- get out and be struck by oncoming traffic.
- operate vehicle equipment and become trapped, for example.

In addition, the children could also set the vehicle in motion by, for example:

- releasing the parking brake.
- changing the transmission position.
- starting the vehicle.
- ▶ Never leave children unattended in the vehicle.
- ▶ When leaving the vehicle, always take the key with you and lock the vehicle.
- ▶ Keep the vehicle key out of the reach of children.

### Overview of recommended child restraint systems

- ① Further information on the correct child restraint system can be obtained at a qualified specialist workshop. Mercedes-Benz recommends that you use a Mercedes-Benz Service Centre for this purpose.

**Securing with ISOFIX****Weight category 0+ (up to 13 kg and up to approx. 15 months)**

Type <sup>1</sup>	BABY SAFE plus
Size categories	E
Approval	E1 04 301 146
Order number <sup>2</sup>	B6 6 86 8224
1 Manufacturer: Britax Römer.	2 With colour code 9H95.

**Weight category I (9 to 18 kg and from approximately 9 months to 4 years)**

Type <sup>1</sup>	DUO plus
Size categories	B1
Approval	E1 04 301 133
Order number <sup>2</sup>	A 000 970 43 02
1 Manufacturer: Britax Römer.	2 With colour code 9H95.

**Securing with the seat belt on the vehicle seat****Weight category 0 (up to 10 kg and approximately 6 months) and weight category 0+ (up to 13 kg and approximately 15 months)**

Type <sup>1</sup>	BABY SAFE plus II
Approval	E1 04 301 146
Order number <sup>2</sup>	A 000 970 38 02
1 Manufacturer: Britax Römer.	2 With colour code 9H95.

**Weight category I (9 to 18 kg and from approximately 9 months to 4 years)**

Type <sup>1</sup>	DUO plus
Approval	E1 04 301 133
Order number <sup>2</sup>	A 000 970 43 02
1 Manufacturer: Britax Römer.	2 With colour code 9H95.

**Weight category II/III (15 to 36 kg and from approximately 3 to 12 years)**

Type <sup>1</sup>	KIDFIX XP
Approval	E1 04 301 304
Order number <sup>2</sup>	A 000 970 49 02

Type <sup>1</sup>	AMG KIDFIX XP
Approval	E1 04 301 304
Order number <sup>2</sup>	A 000 970 33 02
1 Manufacturer: Britax Römer.	2 With colour code 9H95.

**Overview of suitable seats in the vehicle for fitting a child restraint system****Left/right rear seat (second and third seat row)**

Preferred securing system:



ISOFIX child seat anchor (→ page 44)



Also secure Top Tether if present (→ page 46)

Alternative securing system:



Seat belt on vehicle seat (→ page 47)

**Co-driver seat**

Securing system:



Seat belt on vehicle seat (→ page 47)

Always observe the following:

- If the co-driver seat is occupied, ensure, both before and during the journey, that the status of the co-driver airbag is correct for the current situation (→ page 37).
- Observe the notes on automatic co-driver airbag shutoff (→ page 36).

**Centre rear seat (second and third seat row)**

Securing system:



Seat belt on vehicle seat (→ page 47)



Also secure Top Tether if present (→ page 46)

**Approval categories for child restraint systems****Only use approved child restraint systems**

Only child restraint systems with the UNECE standard UN-R44 are approved for use in the vehicle.

**Identification on the child restraint system**

Information about the approval category, weight category and approval number, for example, is on the approval label on the child restraint system.

There may be further information such as the ISO-FIX size categories, depending on the approval category of the child restraint system.

## Approval categories in accordance with UN-R44

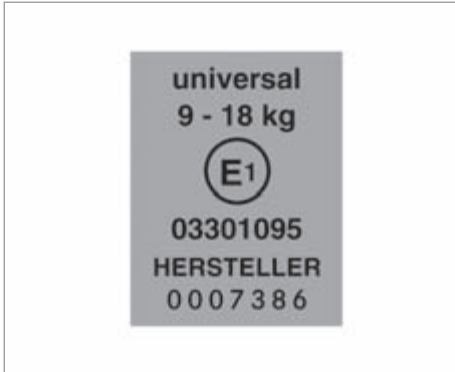

Example of an approval label

- **Universal:** child restraint systems in the "Universal" category are approved for installation in vehicles. They can be used, in accordance with overviews of the suitability of seats for securing child restraint systems, on seats labelled U, UF or IUF.

The IUF label refers to an ISOFIX child restraint system in the "Universal" category. These child restraint systems must also be secured using Top Tether or support points.

- **Semi-Universal:** child restraint systems in the "Semi-Universal" category may only be used if the vehicle and vehicle seat are listed in the child restraint system manufacturer's vehicle model list.
- **Vehicle-specific:** child restraint systems in the "Vehicle-specific" category may only be used if the vehicle and vehicle seat are listed in the child restraint system manufacturer's vehicle model list.

### Please note the suitability of the vehicle seats

Depending on the approval category, there are forward-facing and rearward-facing child restraint systems. Their use may be restricted for certain vehicle seats.

- Suitability of seats for attaching ISOFIX child restraint systems (→ page 44)
- Suitability of seats for attaching belt-secured child restraint systems (→ page 47)

## Fitting an ISOFIX child restraint system on the rear seat

### Overview of suitability of the seats for attaching ISOFIX child restraint systems

#### ISOFIX designation



ISOFIX is a standardised securing system for special restraint systems.

- The symbol indicates seats suitable for attaching an ISOFIX child restraint system in accordance with UN R44 (→ page 42).
- Attach only child restraint systems that are approved in accordance with UN R44 as per the following ISOFIX tables.

Size class:	Equipment:	Rear seat / rear bench seat	
<b>Carry cot</b>			
F	ISO/L1	X (rear seat)	IL <sup>1</sup> (rear bench seat)
G	ISO/L2	X (rear seat)	IL <sup>2,3</sup> (rear bench seat)
<b>Weight group 0 (up to 10 kg and up to approx. 6 months)</b>			
E	ISO/R1	IL <sup>2,3</sup>	
<b>Weight group 0+ (up to 13 kg and up to approx. 15 months)</b>			
E	ISO/R1	IL <sup>2,3</sup>	
D	ISO/R2	IL <sup>2,3</sup>	
C	ISO/R3	IL <sup>2,3,4</sup>	
<b>Weight group 1 (9–18 kg and approx. 9 months to 4 years)</b>			
D	ISO/R2	IL <sup>2,3</sup>	
C	ISO/R3	IL <sup>2,3,4</sup>	
B	ISO/F2	IUF	
B1	ISO/F2X	IUF	
A	ISO/F3	IUF	

Size class:	Equipment:	Rear seat / rear bench seat
X	Not suitable for an ISOFIX child restraint system in this weight group and/or size class.	
IL	Suitable for ISOFIX child restraint systems according to the table in "Overview of the recommended child restraint systems", or if the vehicle and the seat are listed on the child restraint system manufacturer's vehicle model list.	
IUF	Suitable for forward-facing ISOFIX child restraint systems of the "Universal" category in this weight group.	
1	Only on the first rear seat row on a rear bench seat	
2	The seat must be installed in the direction of travel.	
3	It is permissible to use a seat on the second rear seat row only if the maximum distance between the two rear seat rows is set. To this end, the seat on the second rear seat row must be fitted in the rearmost position allowed and the seat on the first rear seat row in front of it must be fitted in the foremost position allowed. If you use the centre seat on the second rear seat row, all seats on the first rear seat row must be fitted in the foremost position allowed.	
4	If you are using a child restraint system in size class C (ISO/R3), make sure that the seat backrest of the front seat is not in contact with the child restraint system. If possible, move the front seat to the highest position and the seat backrest to the upright position.	

### Fitting an ISOFIX child restraint system on the rear seat

**⚠ WARNING** Risk of injury or death if the permissible gross mass of the child and child restraint system together is exceeded.

Too much load may be placed on the ISOFIX child restraint system and the child may not be restrained correctly in the event of an accident, for example.

- ▶ If the child and the child restraint system together weigh more than the permissible gross mass of 33 kg, only use an ISOFIX child restraint system with which the child is secured with the vehicle seat belt.
- ▶ Also secure the child restraint system with the Top Tether belt, if available.

Always comply with the information about the mass of the child restraint system:

- in the manufacturer's installation and operating instructions for the child restraint system used
- on a label on the child restraint system, if available

Check regularly that the permissible gross mass of the child plus the child restraint system is not exceeded.

When you install a child restraint system, observe the following:

- Always observe the correct use and suitability of the seats for attaching a child restraint system.

ISOFIX child seat anchor (→ page 44)

- Always observe the manufacturer's installation and operating instructions for the child restraint system used.
- Make sure that the child's feet do not touch the front seat. If necessary, move the front seat slightly forwards.

 When fitting an ISOFIX child restraint system, also observe the following:

- When using a Group 0/0+ baby car seat and a Group 1 rearward-facing child restraint system on a rear seat:** adjust the front seat so that the seat does not touch the child restraint system.
- Move the rear seat backrest to an upright position before you fit the child seat. Do not adjust the seat backrest when an ISOFIX child restraint system is fitted.
- For certain child restraint systems in weight category 2 or 3, there may be restrictions on the maximum size setting, e.g. due to possible contact with the roof.
- Do not put the child restraint system under strain between the roof and the sitting surface and/or fit it facing the wrong direction.

- ✓ Do not put the child restraint system under strain by the head restraint. Adjust the head restraints as appropriate.

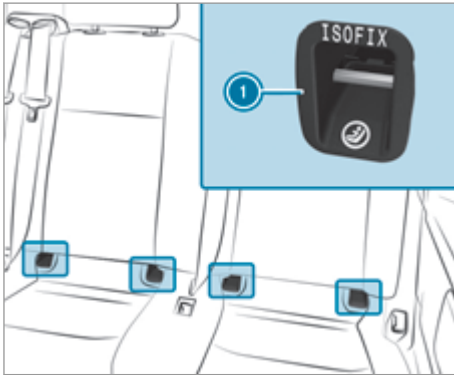

① ISOFIX mounting brackets

Before every journey, make sure that the ISOFIX child restraint system is engaged correctly in both mounting brackets in the vehicle.

**!** **NOTE** Damage to the seat belt for the centre seat during installation of the child restraint system

- ▶ Make sure that the seat belt is not trapped.

- ▶ Attach the ISOFIX child restraint system to both mounting brackets ① in the vehicle.

### Securing Top Tether

**!** **NOTE** Damage to the single rear seat when you use the EASY ENTRY easy entry and exit feature and a child restraint system secured using Top Tether

If a child restraint system is secured using Top Tether and the EASY ENTRY easy entry and exit feature is used, the single rear seat may be damaged.

- ▶ Before you use the EASY ENTRY easy entry and exit feature, unhook the Top Tether hook from the anchorage.

-  If the child restraint system is equipped with a Top Tether belt:

The risk of injury can be reduced by Top Tether. The Top Tether belt enables an additional connection between the child

restraint system attached with ISOFIX and the vehicle.

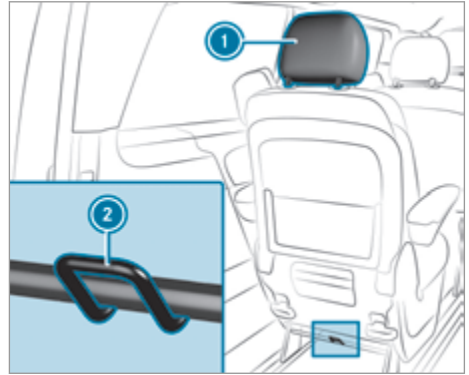

Example

Top Tether anchorage ② is on the lower part of the rear seat on the cross strut between the seats or bench seat legs.

- ▶ If necessary, move head restraint ① upwards (→ page 97).
- ▶ Fit the ISOFIX child restraint system with Top Tether. Comply with the child restraint system manufacturer's installation instructions.

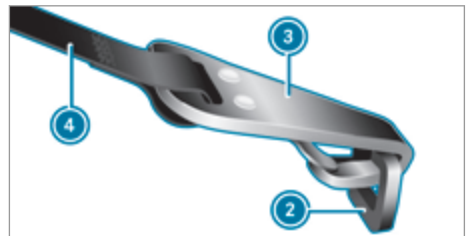

- ▶ Guide Top Tether belt ④ under head restraint ① between the two head restraint bars.
- ▶ Hook Top Tether hook ③ into Top Tether anchorage ② without twisting.
- ▶ Tension Top Tether belt ④. Comply with the child restraint system manufacturer's installation instructions.
- ▶ If necessary, slide head restraint ① downwards (→ page 97). Make sure that you do not interfere with the correct routing of Top Tether belt ④.

## Securing the child restraint system with the seat belt

### Notes on the suitability of seats for attaching belt-secured child restraint systems

Suitability of seats for attaching belt-secured child restraint systems

#### Rear seats

<b>Weight category 0: up to 10 kg</b>	
Rear seat	U <sup>1</sup>
Rear bench seat	U <sup>1</sup> , L <sup>1</sup>
<b>Weight category 0+: up to 13 kg</b>	
Rear seat	U <sup>1</sup>
Rear bench seat	U <sup>1</sup> , L <sup>1</sup>
<b>Weight category I: 9 to 18 kg</b>	
Rear seat	U <sup>1</sup> , L <sup>1</sup>

Rear bench seat	U <sup>1</sup> , L <sup>1</sup>
<b>Weight category II: 15 to 25 kg</b>	
Rear seat	U, L
Rear bench seat	U, L
<b>Weight category III: 22 to 36 kg</b>	
Rear seat	U, L
Rear bench seat	U, L
U Suitable for child restraint systems of the "Universal" category in this weight category.	
L Suitable for semi-universal child restraint systems according to the table in "Recommended child restraint systems", or if the vehicle and the seat are listed in the child restraint system manufacturer's vehicle model list.	
1 The seat must be installed in the direction of travel.	

#### Co-driver seat – Notes

##### Notes on child restraint systems on the co-driver seat

- If it is absolutely necessary for you to fit a child restraint system to the co-driver seat, be sure to observe the information on child restraint systems on the co-driver seat (→ page 49).
- Observe the specific instructions for the rearward-facing and forward-facing child restraint systems. If the co-driver seat is occupied, ensure, both before and during the journey, that the status of the co-driver airbag is correct for the current situation (→ page 37).

#### Co-driver seat/co-driver bench seat

<b>Weight category 0: up to 10 kg</b>	
Co-driver airbag enabled	X
Co-driver airbag disabled <sup>1</sup>	U <sup>2</sup> , L
<b>Weight category 0+: up to 13 kg</b>	
Co-driver airbag enabled	X
Co-driver airbag disabled <sup>1</sup>	U <sup>2</sup> , L
<b>Weight category I: 9 to 18 kg</b>	
Co-driver airbag enabled	UF <sup>2</sup> , L
Co-driver airbag disabled <sup>1</sup>	U <sup>2</sup> , L
<b>Weight category II: 15 to 25 kg</b>	
Co-driver airbag enabled	UF <sup>2</sup> , L

Co-driver airbag disabled <sup>1</sup>	U <sup>2</sup> , L
<b>Weight category III: 22 to 36 kg</b>	
Co-driver airbag enabled	UF <sup>2</sup> , L
Co-driver airbag disabled <sup>1</sup>	U <sup>2</sup> , L

X Not suitable for children in this weight category.
U Suitable for child restraint systems of the "Universal" category in this weight category.
UF Suitable for forward-facing child restraint systems of the "Universal" category in this weight category.
L Suitable for semi-universal child restraint systems according to the table in "Recommended child restraint systems", or if the vehicle and the seat are listed in the child restraint system manufacturer's vehicle model list.
1 The vehicle is equipped with automatic co-driver airbag shutoff. The PASSENGER AIR BAG OFF indicator lamp must be lit.
2 In combination with a long seat belt buckle (police seat) not suitable for child restraint systems.

### Securing the child restraint system with the seat belt on the rear seat

When fitting a belt-secured child restraint system, observe the following:

- ✓ Always observe the manufacturer's installation and operating instructions for the child restraint system used.
- ✓ For a child restraint system in the "Universal" or "Semi-Universal" category, make sure that the system has been approved for the vehicle seat.  
Observe the notes under "Suitability of seats for attaching belt-secured child restraint systems" (→ page 47).
- ✓ **When using a baby car seat in weight category 0/0+ and a rearward-facing child restraint system in weight category I on a rear seat:** adjust the front seat so that the seat does not touch the child restraint system.
- ✓ **When using a forward-facing child restraint system in weight category I:** remove the head restraint from the respective seat, if possible.  
After the child restraint system has been removed, replace the head restraint immediately and adjust all head restraints correctly.
- ✓ The backrest of the forward-facing child restraint system must, as far as possible, be resting on the seat backrest of the rear seat.
- ✓ For certain child restraint systems in weight category II or III, there may be restrictions on the maximum size setting, e.g. due to possible contact with the roof.

- ✓ The child restraint system must not be put under strain between the roof and the seat cushion and/or be fitted facing the wrong direction. Where possible, adjust the seat cushion inclination accordingly.
  - ✓ The child restraint system must not be put under strain by the head restraint. Adjust the head restraints as appropriate.
  - ✓ Make sure that the child's feet do not touch the front seat. If necessary, move the front seat slightly forwards.
- ▶ Install the child restraint system.  
The entire base of the child restraint system must always rest on the sitting surface of the rear seat.
- ▶ Always make sure that the shoulder belt strap is correctly routed from the seat belt outlet of the vehicle to the shoulder belt guide on the child restraint system.  
The shoulder belt strap must be routed forwards and downwards from the seat belt outlet.

### Instructions for vehicles without automatic co-driver airbag shutoff



The sticker is visible when the co-driver door is open:

Vehicles without an automatic co-driver airbag shutoff have a special sticker affixed to the side of the cockpit on the co-driver side.

If you turn the key to position **2** in the ignition lock, the PASSENGER AIR BAG OFF and PASSENGER AIR BAG ON indicator lamps light up briefly. However, they have no function and are not an indication of the automatic co-driver airbag shutoff.

Be sure to observe the following notes:

- Never fit a rearward-facing child restraint system to the co-driver seat.
- Always fit a rearward-facing child restraint system to a suitable rear seat
  - Suitability of seats for attaching belt-secured child restraint systems (→ page 47)
  - Securing the child restraint system with the seat belt on the rear seat (→ page 48)
- Notes on rearward-facing and forward-facing child restraint systems on the co-driver seat (→ page 49)

### Notes on rearward-facing and forward-facing child restraint systems on the co-driver seat

**⚠ WARNING** Risk of injury or death when using a child restraint system while the co-driver airbag is enabled

If you secure a child in a child restraint system on the co-driver seat and the PASSENGER AIR BAG OFF indicator lamp is off, the co-driver airbag can deploy in the event of an accident.

The child could be struck by the airbag.

▶ Always ensure that the co-driver airbag is disabled. The PASSENGER AIR BAG OFF indicator lamp must be lit.

NEVER use a rearward facing child restraint on a seat protected by an ENABLED AIRBAG in front of it, DEATH or SERIOUS INJURY to the CHILD may occur.

Observe the specific instructions for the rearward-facing and forward-facing child restraint systems (→ page 49).



Warning notice on the co-driver sun visor

Always observe the status of the co-driver airbag on the PASSENGER AIR BAG OFF indicator

- If it is absolutely necessary to fit a child restraint system to the co-driver seat, always observe the information on automatic co-driver airbag shutoff (→ page 36).
- When using a rearward-facing child restraint system on the co-driver seat, the co-driver airbag must always be disabled. It is only disabled if the PASSENGER AIR BAG OFF indicator lamp is continuously lit up (→ page 37).
- If the PASSENGER AIR BAG OFF indicator lamp is off, the co-driver airbag is enabled. The co-driver airbag may deploy during an accident.

### Securing the child restraint system with the seat belt on the co-driver seat

When fitting a belt-secured child restraint system on the co-driver seat, always observe the following:

- ☑ Observe the notes on rearward-facing and forward-facing child restraint systems on the co-driver seat (→ page 49).
- ☑ Observe the child restraint system manufacturer's installation and operating instructions.
- ☑ For a child restraint system in the "Universal" or "Semi-Universal" category, make sure that the system has been approved for the vehicle seat.
  - Observe the notes under "Suitability of seats for attaching belt-secured child restraint systems" (→ page 47).
- ☑ When using a forward-facing child restraint system in category I: remove the head restraint from the respective seat, if possible. After the child restraint system has been removed, replace the head restraint immediately and adjust all head restraints correctly.
- ☑ The backrest of the forward-facing child restraint system must, as far as possible, be resting on the seat backrest of the co-driver seat.
- ☑ For certain child restraint systems in weight category II or III, there may be restrictions on the maximum size setting, e.g. due to possible contact with the roof.
- ☑ The child restraint system must not be put under strain between the roof and the seat cushion and/or be fitted facing the wrong direction.

- ✓ The child restraint system must not be put under strain by the head restraint. Adjust the head restraints as appropriate.
- ✓ Never place objects (e.g. cushions) under or behind the child restraint system.

**⚠ WARNING** Risk of injury or death due to objects between the seat surface and the child restraint system

Objects between the seat surface and the child restraint system could affect the function of the automatic front passenger airbag shut-off.

- ▶ Do not place any objects between the seat surface and the child restraint system.
  - ▶ Always make sure that the child restraint system is correctly fitted.
- ▶ Set the co-driver seat as far back as possible and move the seat into the highest position possible.
  - ▶ Fully retract the seat cushion length adjustment.
  - ▶ Set the seat backrest to the most vertical position possible.
  - ▶ Install the child restraint system. The entire base of the child restraint system must always rest on the sitting surface of the co-driver seat.
  - ▶ Always make sure that the shoulder belt strap is correctly routed from the seat belt outlet of the vehicle to the shoulder belt guide on the child restraint system. The shoulder belt strap must be routed forwards and downwards from the seat belt outlet.
  - ▶ If necessary, adjust the seat belt outlet and the co-driver seat as appropriate.

## Child safety locks

### Activating or deactivating child safety locks for the sliding doors

**⚠ WARNING** Risk of accident and injury due to leaving children unattended in the vehicle

If children are left unattended in the vehicle, they could, in particular:

- open doors, thereby endangering other persons or road users.
- get out and be struck by oncoming traffic.
- operate vehicle equipment and become trapped, for example.

In addition, the children could also set the vehicle in motion by, for example:

- releasing the parking brake.
- changing the transmission position.
- starting the vehicle.

- ▶ Never leave children unattended in the vehicle.
- ▶ When leaving the vehicle, always take the key with you and lock the vehicle.
- ▶ Keep the vehicle key out of the reach of children.

**⚠ WARNING** Risk of fatal injury due to exposure to extreme heat or cold in the vehicle

If persons, particularly children, are subjected to prolonged exposure to intense heat or cold, there is a risk of severe injury or even death.

- ▶ Never leave persons, particularly children, unattended in the vehicle.

**⚠ WARNING** Risk of accident and injury due to children left unattended in the vehicle

If children are travelling in the vehicle, they could, in particular:

- open doors, thereby endangering other persons or road users
- get out and be struck by oncoming traffic
- operate vehicle equipment and become trapped, for example

- ▶ Always activate the child safety locks installed if children are travelling in the vehicle.

- ▶ Never leave children unattended in the vehicle.
- ▶ When leaving the vehicle, always take the key with you and lock the vehicle.

The following doors have child safety locks:

- Sliding doors
- Pop-out windows

The child safety locks on the doors secure each door separately. The doors can no longer be opened from the inside (exception: electric sliding door). When the vehicle is unlocked, the door can be opened from the outside.

If the electric sliding door is secured, only the sliding door controls in the rear are deactivated. The electric sliding door can be opened at any time using the switch in the centre console.

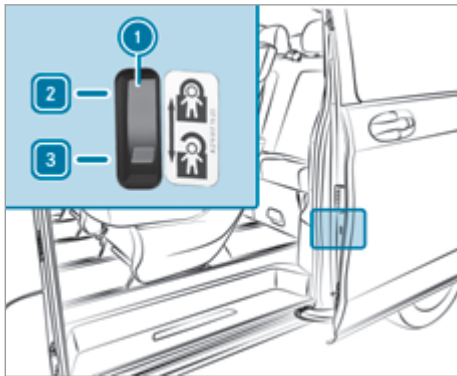

- ▶ Slide the child safety lock latch ① into position 2 (secure) or 3 (unlock).
- ▶ Make sure that the child safety locks are working properly.

### Activating or deactivating child safety locks for hinged windows

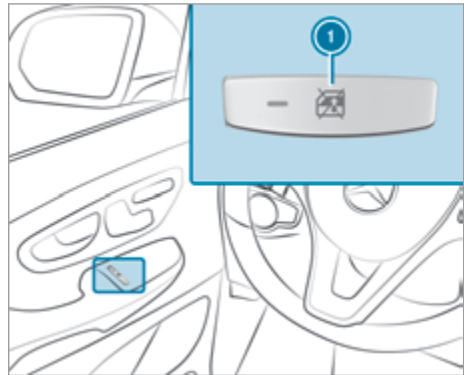

- ▶ **To activate and deactivate:** press button ①. If the indicator lamp on button ① is lit, operation of the electrical hinged windows is disabled. Operation is then only possible using the buttons in the driver's door.

### Notes on pets in the vehicle

**⚠ WARNING** Risk of accident and injury due to animals left unsecured or unattended in the vehicle

If you leave animals in the vehicle unattended or unsecured, they could press buttons or switches, for instance.

An animal may:

- activate vehicle equipment and become trapped, for example
- switch systems on or off and endanger other road users

Unsecured animals may be thrown about the vehicle in the event of an accident, or sudden steering and braking manoeuvres, and injure vehicle occupants.

- ▶ Never leave animals unattended in the vehicle.
- ▶ Always correctly secure animals while driving, e.g. using a suitable animal carrier.

## Key

## Overview of key functions

**⚠ WARNING** Risk of accident and injury due to leaving children unattended in the vehicle

If children are left unattended in the vehicle, they could, in particular:

- open doors, thereby endangering other persons or road users.
- get out and be struck by oncoming traffic.
- operate vehicle equipment and become trapped, for example.

In addition, the children could also set the vehicle in motion by, for example:

- releasing the parking brake.
- changing the transmission position.
- starting the vehicle.

- ▶ Never leave children unattended in the vehicle.
- ▶ When leaving the vehicle, always take the key with you and lock the vehicle.
- ▶ Keep the vehicle key out of the reach of children.

**⚠ WARNING** Risk of accident due to the key inadvertently turning in the ignition lock

If heavy or large objects are attached to the key, the key can inadvertently turn in the ignition lock.

- ▶ Do not attach large or heavy objects to the key.
- ▶ Remove the key from a bulky bunch of keys before inserting it into the ignition lock.

**❗ NOTE** Damage to the key caused by magnetic fields

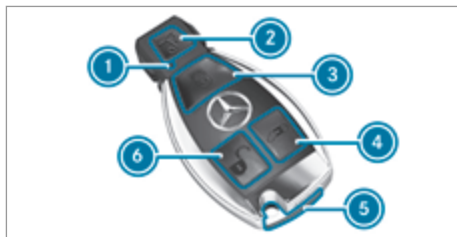

- ▶ Keep the key away from strong magnetic fields.



Key (example: vehicles with an EASY-PACK tailgate and/or rear window which can be opened separately)

- ① Indicator lamp
  - ② To open or close the EASY-PACK tailgate, or to unlock the rear window which can be opened separately
  - ③ To lock the vehicle centrally
  - ④ To unlock the EASY-PACK tailgate and sliding doors, or to unlock and open/close the electric sliding door
  - ⑤ Emergency key
  - ⑥ To unlock the vehicle centrally or only the driver's door
- ⓘ If you do not open the vehicle within approximately 40 seconds of unlocking, the vehicle will lock again and anti-theft protection will be primed again.

Do not keep the key together with electronic devices or metallic objects. This can affect the key's functionality.

- ⓘ If the indicator lamp does not light up when you press the  or  button, the battery is discharged.

Replace the key battery (→ page 53).

### Activating/deactivating the acoustic locking verification signal

Multimedia system:

→  **Settings** **» Vehicle**



▶ Activate or deactivate **Acoustic lock**.

ⓘ **Please note:**

The selected setting for the acoustic locking verification signal must comply with the applicable national road traffic rules. In some countries, including Germany, using the acoustic locking verification signal is forbidden by traffic laws (in accordance with §16 Para. 1 and §30 Para. 1 of the German national road traffic regulations). The driver of the vehicle must ensure compliance with these regulations. In countries where the use of this function is forbidden, this function is not activated in the vehicle and must not be activated.

### Changing the unlocking settings

The key has the following adjustable unlocking functions:

- unlock centrally
  - unlock the driver's door
- ▶ **To switch between settings:** press and hold the  and  buttons at the same time for approximately six seconds until the indicator lamp flashes twice.
- ▶ **To unlock the vehicle centrally when the unlocking function is selected for the driver's door:** press the  button a second time.

### Removing and inserting the emergency key



- ⓘ The anti-theft alarm system (ATA) is triggered when you unlock and open the vehicle using the emergency key (→ page 69).
- ▶ **To remove:** push release catch ① in the direction of the arrow and simultaneously pull emergency key ② completely out of the key.
- ▶ **To insert:** push emergency key ② completely into the key until it engages and release catch ① is back in its initial position.

### Replacing the key battery

**⚠ DANGER** Risk of fatal injuries due to swallowing batteries

Batteries contain toxic and corrosive substances. Swallowing batteries may cause severe internal burns to occur within two hours.

There is a risk of fatal injury.

- ▶ Keep batteries out of the reach of children.
- ▶ If the battery compartment does not close securely, do not use the key any longer and keep it out of the reach of children.
- ▶ If batteries are swallowed, seek medical attention immediately.

**🔥 ENVIRONMENTAL NOTE** Environmental damage due to improper disposal of batteries



Batteries contain pollutants. It is illegal to dispose of them with the household rubbish.



Dispose of batteries in an environmentally responsible manner. Take discharged batteries to a qualified specialist workshop or to a collection point for used batteries.

### Requirements

- you require a CR 2025 3 V cell battery

### Changing the battery

Mercedes-Benz recommends that you have the battery changed at a qualified specialist workshop.

- ▶ Remove the emergency key (→ page 53).

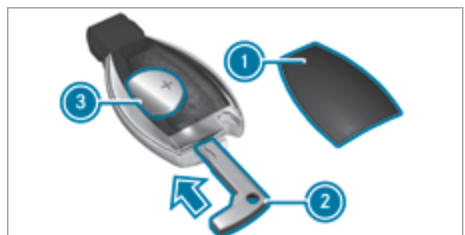

- ▶ Press emergency key ② into the opening in the key in the direction of the arrow until battery compartment cover ① opens. When doing so, do not hold battery compartment cover ① shut.
- ▶ Tap the key against the palm of your hand so that battery ③ falls out of the battery compartment.
- ▶ Insert the new battery into the battery tray with the positive pole facing upwards. Use a lint-free cloth to do so.
- ▶ Fit battery compartment cover ① to the key casing with the front lugs first and push it closed.
- ▶ Slide emergency key ② back into the key (→ page 53).

### Rectifying problems with the key

#### It is no longer possible to lock the vehicle using the key.

Possible causes:

- The doors are not closed properly.
  - The central locking system has malfunctioned.
- ▶ Close the doors properly and lock the vehicle again.
  - ▶ Lock the vehicle using the emergency key (→ page 53) or press down the locking pins and then close the doors.
  - ▶ Have the central locking system checked as soon as possible at a qualified specialist workshop.

#### You can no longer lock or unlock the vehicle.

Possible causes:

- The key battery is weak or discharged.
  - The key is faulty.
- ▶ Check the battery using the indicator lamp and replace the battery, if necessary (→ page 52).
  - ▶ Use the emergency key element to lock and unlock the vehicle (→ page 53).
  - ▶ Have the key checked at a qualified specialist workshop.

#### The vehicle will not start with the key.

Possible causes:

- The on-board electrical system voltage is too low.
- ▶ Switch off all non-essential consumers, such as interior lighting, and try to start the vehicle again.

If this does not work:

- ▶ Check the starter battery and charge it, if necessary (→ page 243).
- or
- ▶ Jump-start the vehicle.
- or
- ▶ Consult a qualified specialist workshop.

#### You have lost a key.

- ▶ Have the key deactivated at a qualified specialist workshop.
- ▶ Report the loss immediately to the vehicle insurers.
- ▶ If necessary, have the locks changed as well.

### Doors

#### Unlocking and opening the door from inside

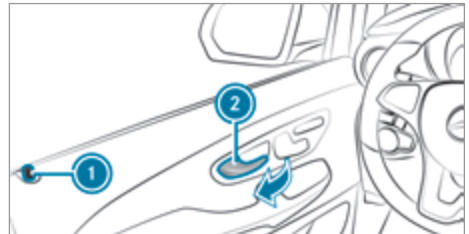

Door handle (example: driver's door)

- ▶ Pull door handle ②.
- Safety pin ① pops up when the door is unlocked.

## Centrally locking and unlocking the door from the inside

**⚠ WARNING** Risk of accident and injury due to leaving children unattended in the vehicle

If children are left unattended in the vehicle, they could, in particular:

- open doors, thereby endangering other persons or road users.
- get out and be struck by oncoming traffic.
- operate vehicle equipment and become trapped, for example.

In addition, the children could also set the vehicle in motion by, for example:

- releasing the parking brake.
- changing the transmission position.
- starting the vehicle.

- ▶ Never leave children unattended in the vehicle.
- ▶ When leaving the vehicle, always take the key with you and lock the vehicle.
- ▶ Keep the vehicle key out of the reach of children.

**⚠ WARNING** Risk of fatal injury due to exposure to extreme heat or cold in the vehicle

If persons, particularly children, are subjected to prolonged exposure to intense heat or cold, there is a risk of severe injury or even death.

- ▶ Never leave persons, particularly children, unattended in the vehicle.

You can use the central locking buttons to centrally lock and unlock the entire vehicle from the inside.

The central locking buttons are located in the driver's door.

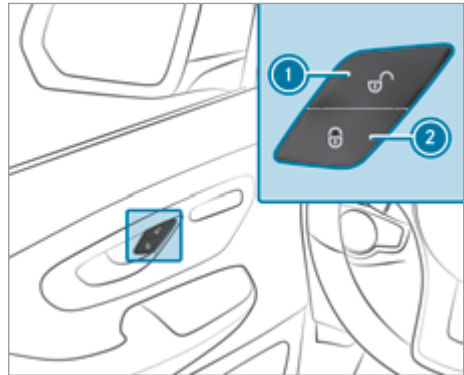

Central locking buttons (vehicles with manually adjustable front seats)

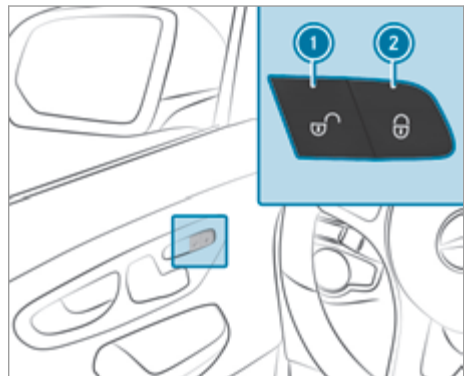

Central locking buttons (vehicles with electrically adjustable front seats)

- ▶ **To lock or unlock the entire vehicle:** press button ① (unlock) or ② (lock) when the doors are closed.

Observe the following settings when locking and unlocking from inside:

- If the driver's or co-driver's door is open, the open door is not locked.  
All other doors and the tailgate are locked.
- If a sliding door or the tailgate is open, only the driver's and co-driver's doors are locked.
- You cannot unlock the vehicle centrally from the inside if the vehicle has been locked with the key.
- If the vehicle has been locked using the central locking button and a door is opened from the

inside, only the door that has been opened is unlocked.

- If the vehicle has previously been locked with the key, opening a door from the inside will trigger the anti-theft alarm system. Switch off the alarm (→ page 69).

### Activating/deactivating the automatic locking mechanism

#### Requirements:

- The power supply or the vehicle has been switched on.
- The doors are closed.

When the automatic locking mechanism is activated and the vehicle is travelling at a speed above 15 km/h, the vehicle is locked automatically.

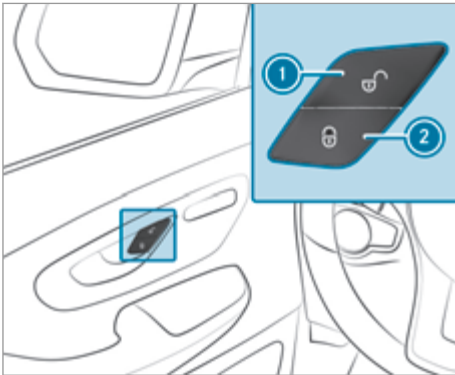

Central locking buttons (vehicles with manually adjustable front seats)

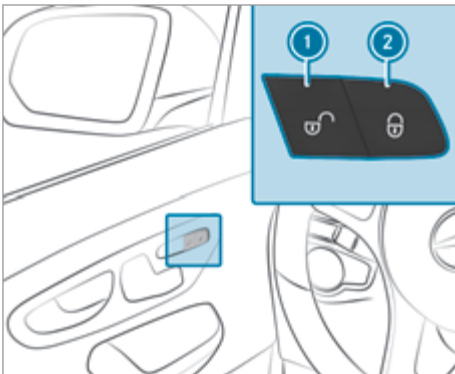

Central locking buttons (vehicles with electrically adjustable front seats)

If the vehicle is being tow-started, push-started or tested on a roller dynamometer, there is a risk of being locked out when the function is activated.

- ▶ **To activate:** press and hold button ② until you hear a tone.
- ▶ **To deactivate:** press and hold button ① until you hear a tone.

### Unlocking and locking the driver's door with the emergency key

- ① To lock the vehicle fully with the emergency key, press down the locking pins of the doors. Then lock the driver's door with the emergency key.
- ▶ **To unlock:** insert the emergency key fully into the driver's door lock and turn it anti-clockwise.
- ▶ **To lock:** insert the emergency key fully into the driver's door lock and turn it clockwise.
- ① **Right-hand drive vehicles:** turn the emergency key in the opposite direction for each case.

### Sliding door

#### Opening/closing the sliding door from outside

- ⚠ **WARNING** Risk of becoming trapped due to an open sliding door which is not engaged in place

On an incline, the sliding door can move by itself.

This can cause you or other people to become trapped.

- ▶ Always make sure that the open sliding door is engaged. To do so, open the sliding door to the stop.

- ⚠ **NOTE** Damage to the sliding door due to incorrect use

Using the lower guide of the sliding door (carriage) as a step can result in damage to the trim and/or mechanical components of the sliding door.

- ▶ Do not use the lower guide of the sliding door (carriage) as a step.

## Opening



The sliding door is equipped with an active retainer, which engages when the door is opened as far as it will go.

- ▶ Pull door handle ① in the direction of the arrow. The sliding door opens.
- ▶ Push back the sliding door using door handle ① until it engages.
- ▶ Check the sliding door catch.

## Closing

- ▶ Pull the sliding door by door handle ①. The sliding door is released from its catch.
- ▶ Push the sliding door firmly forwards using door handle ① and close it.

## Opening/closing the sliding door from inside

**⚠ WARNING** Risk of becoming trapped due to sliding door opening towards the rear

When you open the sliding door, the sliding door could hit other people as it moves towards the rear of the vehicle.

- ▶ Only open the sliding door when traffic conditions permit.

## Requirements:

- The child safety lock is deactivated.

## Opening

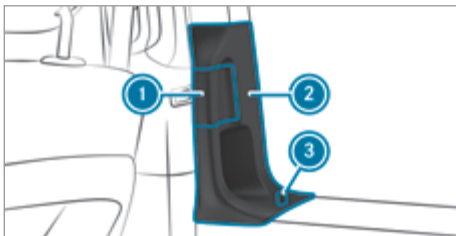

- ▶ Pull back rocker switch ①. If the door is locked, locking pin ③ pops up. The sliding door unlocks and opens.
- ▶ Push back the sliding door using door handle ② until it engages.
- ▶ Check the sliding door catch.

## Closing

- ▶ Push rocker switch ① forwards. The sliding door is released from its catch.
- ▶ Push the sliding door forwards using door handle ② and close it.

## Electric sliding door

### Function of the electric sliding door

**⚠ WARNING** Risk of becoming trapped due to sliding door opening towards the rear

When you open the sliding door, the sliding door could hit other people as it moves towards the rear of the vehicle.

- ▶ Only open the sliding door when traffic conditions permit.

**ⓘ NOTE** Damage to the sliding door due to incorrect use

Using the lower guide of the sliding door (carriage) as a step can result in damage to the trim and/or mechanical components of the sliding door.

- ▶ Do not use the lower guide of the sliding door (carriage) as a step.

You must reset the electric sliding door if there has been a malfunction or a drop in voltage (→ page 60).

Your vehicle can be equipped with an electric sliding door on the left and/or right-hand side.

You can open and close the sliding door with these controls:

- Sliding door buttons on the centre console
- Sliding door button on the door sill (B-pillar)
- Door handle (inside or outside)
- Key

## Automatic blockage detection with sliding door reversing function

If a solid object blocks or restricts the sliding door during the automatic closing process, the sliding

door opens again automatically. If the sliding door is obstructed during the opening procedure, it moves back a few centimetres in the opposite direction and stops.

The automatic blockage detection with reversing function is only an aid. It is not a substitute for your attentiveness when closing the electrical sliding door.

If an obstacle is detected, the display shows the **Left-hand electric sliding door Obstruction detected** message, for example, and five warning tones sound.

- i** In unfavourable operating conditions, e.g. frost, ice or heavy soiling, press and hold the appropriate sliding door button. The electric sliding door moves with increased force. Observe that in such circumstances, the blockage detection is less sensitive. To stop the movement, release the sliding door button.

**⚠ WARNING** Risk of becoming trapped despite reversing function

The reversing feature does not react:

- to soft, light and thin objects, e.g. fingers
- over the last 8 mm of the closing movement

The reversing feature therefore cannot prevent someone being trapped in these situations.

- ▶ Make sure that no body parts are in the closing area.

If someone becomes trapped, take the following actions:

- press the  button on the key or
- pull the exterior door handle or
- press the appropriate sliding door button in the centre console or
- press the button on the door sill or
- pull the rocker switch on the door handle

### Opening and closing the electric sliding door from the inside

**⚠ WARNING** Risk of becoming trapped due to sliding door opening towards the rear

When you open the sliding door, the sliding door could hit other people as it moves towards the rear of the vehicle.

- ▶ Only open the sliding door when traffic conditions permit.

### Opening

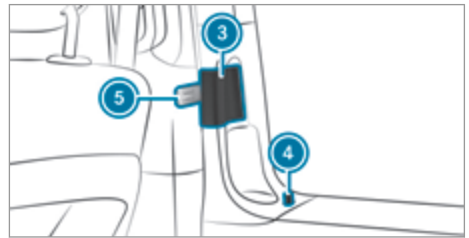
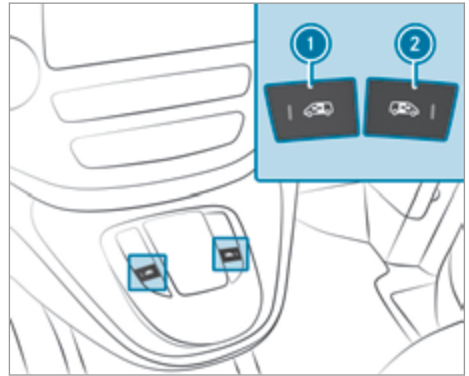

- 1 Sliding door button for the sliding door on the left-hand side
- 2 Sliding door button for the sliding door on the right-hand side
- 3 Rocker switch
- 4 Safety pin
- 5 Sliding door button in the door sill

You can only open a sliding door with sliding door button **5** in the door sill or with rocker switch **3** on the door handle if the child-proof lock has not been activated.

The sliding door is equipped with an active retainer, which engages the door at the end stop when opened.

- ▶ Briefly press appropriate sliding door button **1** or **2** in the centre console.

or

- ▶ Press sliding door button **5** in the door sill.

or

- ▶ Briefly pull back rocker switch ③.
- If the door is locked, locking pin ④ pops up. The sliding door unlocks, automatic operation is started and the sliding door opens.
- If you use sliding door button ① or ② in the centre console you will hear two warning signals during the opening procedure.
- The indicator lamp in sliding door button ① or ② in the centre console flashes for the duration of automatic operation.
- The indicator lamp in sliding door button ① or ② in the centre console is lit whenever the appropriate sliding door is open. Depending on the vehicle equipment, the display can also show the **Sliding door open** message.

### Closing





- ▶ Briefly press appropriate sliding door button ① or ② in the centre console.
- or
- ▶ Press sliding door button ⑤ in the door sill.
- or
- ▶ Briefly push rocker switch ③ forwards.
- The sliding door is released from its lock and automatic operation is started. The sliding door closes.
- If you use sliding door button ① or ② in the centre console you will hear two warning signals during the closing procedure.
- The indicator lamp in sliding door button ① or ② in the centre console goes out whenever the corresponding sliding door is closed.

### Interrupting automatic operation

- ▶ Press corresponding sliding door button ① or ② in the centre console again.
- or
- ▶ Press sliding door button ⑤ in the door sill again.
- or
- ▶ Briefly pull back rocker switch ③.

### Opening/closing the electric sliding door with the key

- ▶ **i** If the vehicle is fitted with two sliding doors, the  button on the key can only be used to open or close one of the two sliding doors (→ page 59).

- ▶ **To unlock:** briefly press the  button on the key.
- ▶ **To open:** press and hold the  button on the key for longer than 0.5 seconds. You will hear two acoustic signals and the sliding door will open automatically.
- ▶ **To close:** press and hold the  button on the key for longer than 0.5 seconds. You will hear two acoustic signals and the sliding door will close automatically.
- ▶ **To interrupt automatic operation:** briefly press the  button on the key. The sliding door stops moving.

### Opening/closing the electrical sliding door from the outside





- ▶ **To open:** pull door handle ①. The sliding door opens. In addition, you will hear two warning signals.
- ▶ **To close:** pull door handle ①. The sliding door closes.
- ▶ **To interrupt automatic operation:** pull door handle ① again.

### Programming the key button for the sliding door

#### Requirements:

- The vehicle is equipped with two electric sliding doors.
- The sliding door to be programmed is open.
- The vehicle is switched on.

The  button on the key can be programmed. Program the  button to open the right or left sliding door.

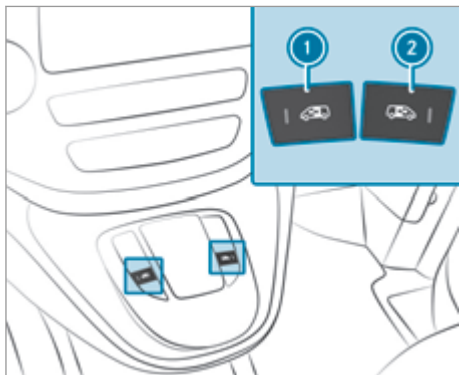





- ① Sliding door button for the sliding door on the left-hand side
- ② Sliding door button for the sliding door on the right-hand side

▶ Press and hold sliding door button ① or ② in the centre console for the appropriate sliding door until the sliding door is closed and four tones have sounded.

The **Left-hand electric sliding door key programmed/Right-hand electric sliding door key programmed** message appears in the display.

### Resetting the electric sliding door

You must reset the electric sliding door if there has been a malfunction or a drop in voltage.

- ▶ If the sliding door is open: close it by hand.
  - ▶ Using the corresponding  or  sliding door button on the centre console, open the sliding door at least 40 cm and then close the sliding door completely.
  - ▶ When the sliding door is closed, open the sliding door fully using the corresponding  or  sliding door button on the centre console.
- The sliding door is reset.

### Rectifying problems with the electric sliding door

#### The electric sliding door is locked in place.

Unfavourable operating conditions, e.g. frost, ice or heavy soiling, may obstruct the function of the sliding door.

- ▶ Press and hold the sliding door button until the sliding door has opened or closed. The sliding door moves with increased force. Observe that in such circumstances, the blockage detection is less sensitive. To stop the movement, release the sliding door button.
- ▶ Remove the cause of the blockage at the earliest opportunity.

## Tailgate

### Opening and closing the tailgate

**⚠ DANGER** Risk of poisoning from exhaust gases

Combustion engines emit poisonous exhaust gases, such as carbon monoxide. Exhaust gases can enter the vehicle interior if the rear window is open when the engine is running, especially if the vehicle is in motion.

- ▶ Always switch off the engine before opening the rear window.
- ▶ Never drive with the rear window open.

**! NOTE** Damage to the tailgate caused by obstacles above the vehicle

The tailgate swings rearwards and upwards when it is opened.

- ▶ Make sure that there is sufficient space behind and above the tailgate.

- ① You will find details of the tailgate opening dimensions under "Technical data" (→ page 281).

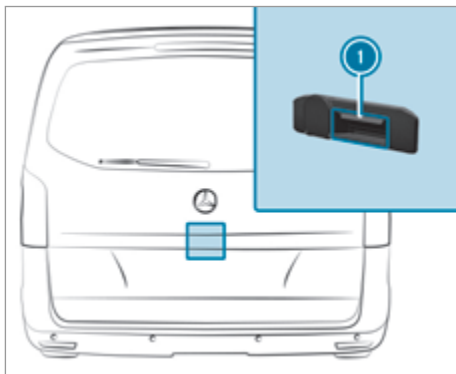

- ▶ **To open:** push button ① on the handle and raise the tailgate.



- ▶ **To close:** pull the tailgate firmly downwards by loop ② and close it from outside.

### Opening the tailgate in an emergency

If the battery voltage is low or the voltage supply is interrupted, the tailgate cannot be opened.

In an emergency, you can open the tailgate using the release catch for service purposes.

- ▶ Prise off the cover on the lower part of the tailgate with a suitable tool, e.g. the screwdriver from the vehicle tool kit.
- ▶ Insert the screwdriver into the opening and move the release lever until the tailgate unlocks and opens.
- ▶ Lift the tailgate upwards.

## EASY-PACK tailgate

### Notes on the EASY-PACK tailgate

**⚠ DANGER** Risk of poisoning from exhaust gases

Combustion engines emit poisonous exhaust gases, such as carbon monoxide. Exhaust gases can enter the vehicle interior if the rear window is open when the engine is running, especially if the vehicle is in motion.

- ▶ Always switch off the engine before opening the rear window.
- ▶ Never drive with the rear window open.

**! NOTE** Damage to the tailgate caused by obstacles above the vehicle

The tailgate swings rearwards and upwards when it is opened.

- ▶ Make sure that there is sufficient space behind and above the tailgate.

- ① You will find details of the tailgate opening dimensions under "Technical data" (→ page 281).

### Obstruction detection with reversing function

The tailgate is equipped with automatic object detection with reversing function. If a solid object blocks or restricts the tailgate during the automatic closing process, the tailgate opens again automatically. The automatic object detection with reversing function is only an aid. It is not a substitute for your attentiveness when closing the tailgate.

**⚠ WARNING** Risk of becoming trapped despite reversing function

The reversing feature does not react:

- to soft, light and thin objects, e.g. fingers
- over the last 8 mm of the closing movement

The reversing feature therefore cannot prevent someone being trapped in these situations.

- ▶ Make sure that no body parts are in the closing area.

If someone is trapped:

- press the  button on the key or
- press the closing button on the tailgate or
- pull the handle of the tailgate

### Opening and closing the EASY-PACK tailgate

**! NOTE** Damage to the tailgate caused by obstacles above the vehicle

The tailgate swings rearwards and upwards when it is opened.

- ▶ Make sure that there is sufficient space behind and above the tailgate.

#### Requirements:

- The rear window is closed.
- The tailgate is unlocked.
- There are no persons within the swinging range of the tailgate.
- The  button on the key is programmed to open and close the tailgate (→ page 63).

## Opening

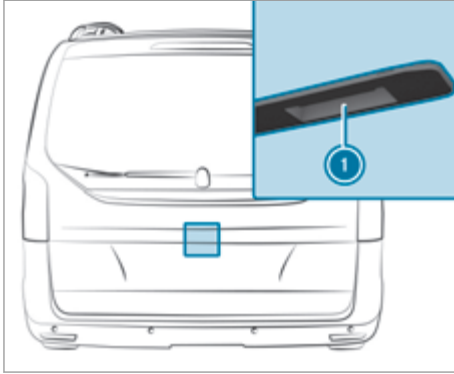

- ▶ Press button ① in the handle and step out of the swinging range of the tailgate.

or

- ▶ Briefly press and hold the  button on the key. Automatic operation is started. The tailgate opens and swings upwards. In addition, you will hear two warning signals.

## Closing

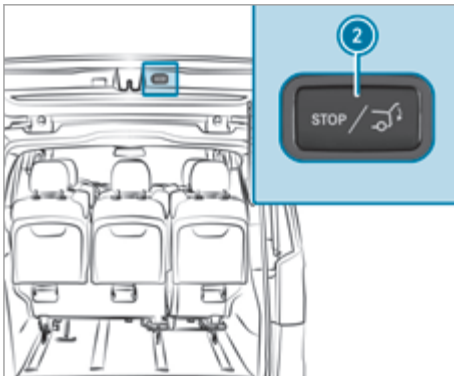

- ▶ Press button ② in the tailgate and step out of the swinging range of the tailgate.

or

- ▶ Briefly press and hold the  button on the key. Automatic operation is started and the tailgate closes. During closing, closing button ② flashes and two warning tones sound.

## Interrupting automatic operation

- ▶ Press button ① in the handle again.
- or
- ▶ Press closing button ② in the tailgate again.
- or
- ▶ Briefly press and hold the  button on the key again.

## Adjusting the opening angle of the tailgate

### Setting the end position

You can set the opening angle of the tailgate by saving the desired position as the end position.

- ▶ Open the tailgate and stop automatic operation in the desired position.
- or
- ▶ Open the tailgate and manually swing it into the desired position.
  - ▶ Press and hold the closing button  on the tailgate until the acoustic signal sounds once. The current position of the tailgate has been saved as the end position.

### Resetting to the maximum opening angle

- ▶ Open the tailgate.
- ▶ Press and hold the closing button  on the tailgate until the acoustic signal sounds twice. The saved end position has been deleted and the tailgate opens again to the maximum extent.

### Resetting the tailgate

You must reset the tailgate if there has been a malfunction or an interruption in the voltage supply.

- ▶ If the tailgate is open: close the tailgate by hand.
- ▶ Briefly press the button in the handle of the tailgate, step out of the swinging range of the tailgate and open the tailgate.
- ▶ When the tailgate is fully open, press the  closing button in the tailgate and step out of the swinging range of the tailgate. The tailgate closes. When the tailgate is fully closed, it is reset and operational.

- ▶ **i** When the  button of the key is programmed for operating the tailgate (→ page 63), you can also use the key to open and close the tailgate.

## Opening and closing the rear window

**⚠ DANGER** Risk of poisoning from exhaust gases

Combustion engines emit poisonous exhaust gases, such as carbon monoxide. Exhaust gases can enter the vehicle interior if the rear window is open when the engine is running, especially if the vehicle is in motion.

- ▶ Always switch off the engine before opening the rear window.
- ▶ Never drive with the rear window open.

### Requirements:

- The vehicle or load compartment is unlocked and the tailgate is closed.
- **To open using the key:**
  - The vehicle is fitted with an EASY-PACK tailgate and the  button on the key is programmed to open the rear window (→ page 63) or the vehicle is equipped with the Bunk Package.

### Opening

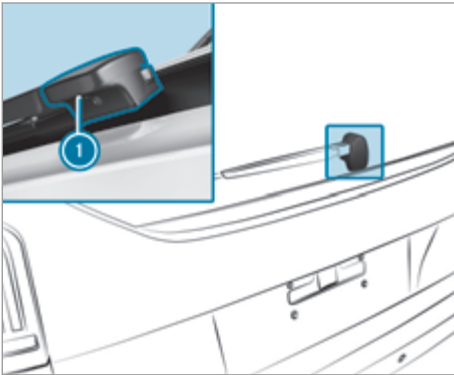

- ▶ Press the  button on the key.
- or
- ▶ Press button ① on the handle on the rear window.

### Closing

- ▶ Swing the rear window down and push it closed.

## Programming the key button for the tailgate or rear window

### Requirements:

- The tailgate and the rear window are closed.
- The vehicle is switched on.

If your vehicle is fitted with an EASY-PACK tailgate, you can program the  button on the key either to open/close the tailgate or to open the rear window.

- ▶ Press the buttons in the handle of the tailgate and in the handle of the rear window simultaneously for approximately five seconds. After successfully changing the function, the vehicle turn signal lamps flash once.
- ▶ Check the function of the  button on the key.

## Side window

### Opening and closing the side windows

**⚠ WARNING** Risk of becoming trapped when opening a side window

When you open a side window, parts of the body could be drawn in or become trapped between the side window and window frame.

- ▶ When opening, make sure that nobody is touching the side window.
- ▶ If someone is trapped, release the button immediately or pull it in order to close the side window again.

**⚠ WARNING** Risk of becoming trapped when closing a side window

When closing a side window, body parts could be trapped in the closing area in the process.

- ▶ When closing, make sure that no body parts are in the closing area.
- ▶ If someone is trapped, release the button immediately or press the button in order to reopen the side window.

**⚠ WARNING** Risk of becoming trapped when children operate the side windows

Children could become trapped if they operate the side windows, particularly when unattended.

- ▶ Activate the child safety lock for the rear side windows.
- ▶ When leaving the vehicle, always take the key with you and lock the vehicle.
- ▶ Never leave children unattended in the vehicle.

**⚠ WARNING** Risk of fatal injury due to exposure to extreme heat or cold in the vehicle

If persons, particularly children, are subjected to prolonged exposure to intense heat or cold, there is a risk of severe injury or even death.

- ▶ Never leave persons, particularly children, unattended in the vehicle.

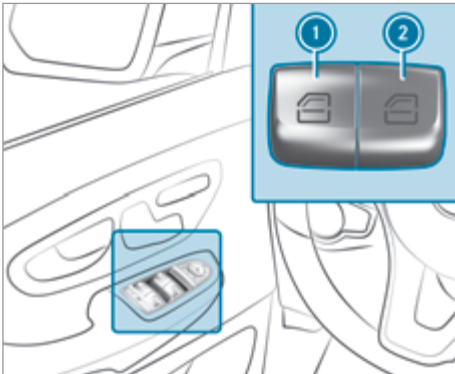

- ▶ **To open manually:** press and hold button ① or ②.
- ▶ **To close manually:** pull and hold button ① or ②.

The windows in the front doors can also be operated automatically.

- ▶ **To open completely:** briefly press button ① or ② beyond the point of resistance. Automatic operation will start.
- ▶ **To close completely:** briefly pull button ① or ② beyond the point of resistance. Automatic operation will start.
- ▶ **To interrupt automatic operation:** briefly press or pull button ① or ② again.

You can still operate the side windows when the vehicle is parked. This function will remain available for around five minutes or until you open a front door.

### Automatic reversing function of the side windows

If an object blocks a side window during the closing process, the side window will open again automatically. The automatic reversing function is only an aid and is not a substitute for your attentiveness.

- ▶ During the closing process, make sure that no body parts are in the closing area.

**⚠ WARNING** Risk of becoming trapped despite there being reversing protection on the side window

The reversing function does not react:

- to soft, light and thin objects, e.g. fingers.
- during resetting.

The reversing function cannot prevent someone from becoming trapped in these situations.

- ▶ During the closing process, make sure that no body parts are in the closing area.
- ▶ If someone becomes trapped, press the  button to open the side window again.

### Opening and closing the hinged window

#### Requirements:

- The power supply or the vehicle has been switched on.

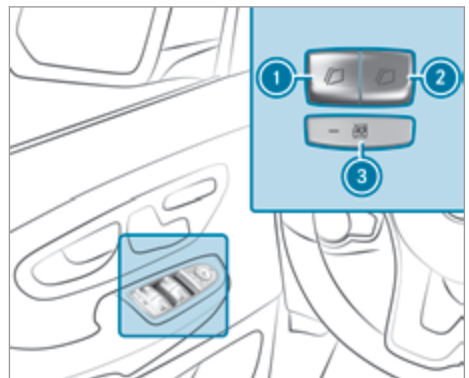

Example: driver's door control panel

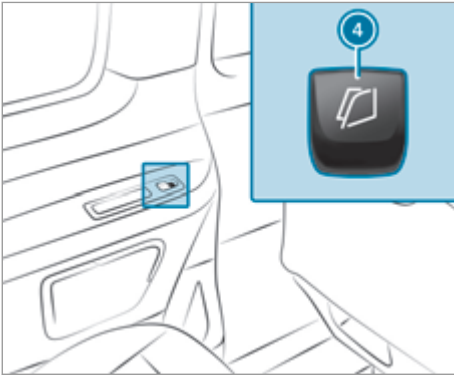

Button in the rear (example: left-hand side of the vehicle)

- ① Opens and closes the rear left hinged window
- ② Opens and closes the rear right hinged window
- ③ Child safety lock for electric hinged window (→ page 51)
- ④ Opens and closes the hinged window

You can operate the hinged window with button ④ only if the child safety lock is not activated.

- ▶ **To start automatic operation:** press/pull the corresponding button beyond the point of resistance.
- ▶ **To stop automatic operation:** press/pull the corresponding button beyond the point of resistance again.

### Ventilating the vehicle before starting a journey (convenience opening)

**⚠ WARNING** Risk of entrapment when opening a side window

When opening a side window, parts of the body could be drawn in or become trapped between the side window and window frame.

- ▶ When opening, make sure that nobody is touching the side window.
- ▶ Release the button immediately if somebody becomes trapped.

The "convenience opening" function can be operated using the key without switching on the vehicle. The key must be in close proximity to the driver's or co-driver door.

- ▶ Press and hold the  button on the key.

The following functions are performed:

- the vehicle is unlocked
- the side windows are opened
- the panoramic sliding sunroof is opened
- the hinged windows are opened
- the seat ventilation for the driver's seat is switched on

- ▶ **To interrupt convenience opening:** release the  button.

### Closing the side windows from the outside (convenience closing)

**⚠ WARNING** Risk of entrapment due to not paying attention during convenience closing

When the convenience closing feature is operating, parts of the body could become trapped in the closing area of the side windows.

- ▶ When the convenience closing feature is operating, monitor the entire closing process and make sure that no body parts are in the closing area.

- ▶ Press and hold the  button on the key.

The following functions are performed:

- the vehicle is locked
- the side windows are closed
- the panoramic sliding sunroof is closed

- ▶ **To interrupt convenience closing:** release the  button.

### Adjusting the side windows

The side windows must be readjusted after a malfunction or a voltage supply interruption.

- ▶ Switch on the power supply (→ page 138).
- ▶ Push both buttons on the power window and hold for approximately one second after the side window has closed.
- ▶ If the side windows remain closed when you release the buttons, they have been reset correctly. If this is not the case, repeat the steps described for the open side windows.

## Rectifying problems with the side windows

**⚠ WARNING** Risk of becoming trapped or fatally injured if reversing protection is not activated

If you close a side window again immediately after it has been blocked, the side window will close with increased or maximum force. The reversing function is then not active and body parts may become trapped.

- ▶ Make sure that no parts of the body are in the closing area.
- ▶ To stop the closing process, release the button or press the button again to reopen the side window.

**You cannot open or close a side window all the way.**

- ▶ Check to see if there are any objects in the window guide.
- ▶ Reset the side windows (→ page 65).

## Panorama sliding sunroof

### Notes on the panorama sliding sunroof

In this section, the term "sliding sunroof" refers to the panorama sliding sunroof.

**⚠ WARNING** Risk of becoming trapped when the sliding sunroof is being opened and closed

Body parts may become trapped in the range of movement.

- ▶ During opening and closing, make sure that no body parts are in the range of movement.
- ▶ Release the button immediately if somebody becomes trapped.

or

- ▶ Briefly press the button in any direction during automatic operation. The opening or closing process will be stopped.

**⚠ WARNING** Risk of entrapment if the sliding sunroof is operated by children

Children operating the sliding sunroof could get caught in the moving parts, particularly if unattended.

- ▶ Never leave children unattended in the vehicle.
- ▶ When leaving the vehicle, always take the key with you and lock the vehicle.

**! NOTE** Malfunction due to snow and ice

Snow and ice may cause the sliding sunroof to malfunction.

- ▶ Open the sliding sunroof only if it is free of snow and ice.

**! NOTE** Damage caused by protruding objects

Objects that protrude from the sliding sunroof may damage the seals.

- ▶ Do not allow anything to protrude from the sliding sunroof.

**! NOTE** Damage to on-board electronics caused by the ingress of water

Water may enter the vehicle interior when the sliding sunroof is being cleaned.

This may damage the on-board electronics.

- ▶ Clean the sliding sunroof only when it is closed.

- ① When the sliding sunroof is open, resonance noise may also occur in addition to the usual airflow noises. This is caused by minor pressure fluctuations in the vehicle interior. To prevent or stop these noises, alter the position of the sliding sunroof or open a side window slightly.

### Sliding sunroof reversing function

The sliding sunroof is equipped with an automatic reversing function. If a solid object prevents or hinders the closing process, the sliding sunroof will open again automatically. The automatic reversing function is only an aid and is not a substitute for your attentiveness in the process of closing the sliding sunroof.

**⚠ WARNING** Risk of becoming trapped even with the reversing feature active

In particular, the reversing function will not react:

- to soft, light and thin objects, e.g. fingers
- over the last 4 mm of the closing path
- during resetting
- when you close the sliding sunroof again manually immediately after automatic reversing

- ▶ During the closing process, make sure that no body parts are in the closing area.
- ▶ Release the button immediately if somebody becomes trapped.

or





- ▶ Press the button in any direction during the automatic closing process. The closing process will be stopped.

### Opening and closing the panorama sliding sunroof

#### Requirements:

- The power supply has been switched on.



- ▶ **To raise (vent position):** press the  button.
- ▶ **To open:** pull back the  button.
- ▶ **To close and lower:** pull down the  button.
- ▶ **To start automatic operation:** push or pull the  button beyond the point of resistance and release it.
- ▶ **To stop automatic operation:** push or pull the  button beyond the point of resistance and release it.

You will still be able to operate the sliding sunroof if you switch off the vehicle or remove the key. This function will remain available for 30 seconds or until you open a front door.

When the power supply is switched off, the sliding sunroof will close automatically in the following situations:

- If it starts to rain
- In the event of extreme outside temperatures
- After six hours
- If there is a malfunction in the power supply

The sliding sunroof will remain raised at the rear to allow the vehicle interior to continue to be ventilated.

The sliding sunroof will not close in the following situations:

- If the sliding sunroof is raised at the rear.
- If the sliding sunroof is obstructed.
- If it is not raining on the field of the rain sensor on the windscreen because the vehicle is underneath a bridge, for example.

If the sliding sunroof closes via the rain closing function and is obstructed in the process, it will open again slightly. The rain closing function will then be disabled.

### Opening and closing the roller sunblinds of the sliding sunroof

**⚠ WARNING** Risk of becoming trapped when the roller sunblind is being opened and closed

Body parts may become trapped between the roller sunblind and frame or sliding roof.

- ▶ When opening or closing, make sure that no body parts are in the roller sunblind's range of movement.
- ▶ Release the button immediately if somebody becomes trapped.

or

- ▶ Briefly press the button in any direction during automatic operation. The opening or closing process will be stopped.

**Requirements:**

- The power supply has been switched on.

**Reversing function of the roller sunblind**

You can open and close the roller sunblind only when the sliding sunroof is closed.

The roller sunblinds are fitted with an automatic reversing function. If a solid object prevents or hinders the closing process, the roller sunblind will open again automatically. The automatic reversing function is only an aid and is not a substitute for your attentiveness in the process of closing the roller sunblinds.

- ▶ When closing the roller sunblind, make sure that no body parts are in the range of movement.

**⚠ WARNING** Risk of becoming trapped despite reversing function

In particular, the reversing function will not react:

- to soft, light and thin objects, e.g. fingers
- when you close the roller sunblind again manually immediately after automatic reversing

- ▶ When closing the roller sunblind, make sure that no body parts are in the range of movement.
- ▶ Release the button immediately if somebody becomes trapped.

or



- ▶ Press the button in any direction during the automatic closing process. The closing process will be stopped.

**Opening and closing roller sunblinds**

You can close the roller sunblinds only when the sliding sunroof is closed.

- ▶ **To open:** press the  button. The roller sunblinds will open, and the sliding sunroof will then be raised into the vent position.

or

- ▶ Pull back the  button. The roller sunblinds will open.
- ▶ **To close:** pull down the  button. When the sliding sunroof is closed, the roller sunblinds will close.

If you push or pull the  button beyond the point of resistance and release it, you will start automatic operation in the direction in question. You can stop automatic operation by pushing or pulling the button again.

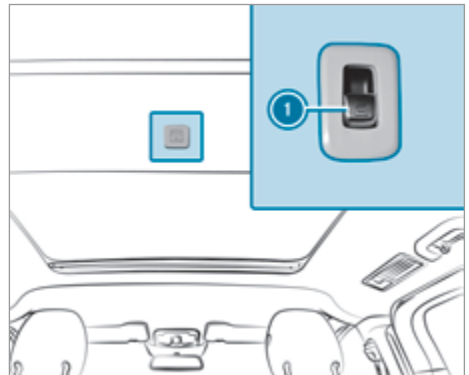
**Opening and closing roller sunblinds from the rear**

- ▶ Push or pull button ① to the point of resistance and hold it until the roller sunblind or the sliding sunroof has reached the desired position.
- ▶ **Automatic operation:** push or pull button ① beyond the point of resistance and release it.

With the sliding sunroof, a complete opening or closing process will always pass through "vent position", a fixed intermediate position. You will need to operate button ① twice to execute a complete opening or closing process.

## Rectifying problems with the sliding sunroof

**⚠ WARNING** Risk of becoming trapped or fatal injuries when the sliding sunroof is closed again

If you close the sliding sunroof again immediately after it has been blocked or reset, the sliding sunroof will close with increased or maximum force.

There is a risk of becoming trapped or even of fatal injuries!

- ▶ Make sure that no parts of the body are in the closing area.
- ▶ Release the button immediately if somebody becomes trapped.

or

- ▶ Briefly press the button in any direction during the automatic closing process. The closing process will be stopped.

### The sliding sunroof cannot be closed and you cannot detect the cause.

If the sliding sunroof is obstructed during closing and opens again slightly:

- ▶ Immediately after the sliding sunroof has been obstructed, pull the  button down again to the point of resistance until the sliding sunroof is closed. The sliding sunroof will be closed with increased force.

If the sliding sunroof is obstructed again and opens again slightly:

- ▶ Immediately after the sliding sunroof has been obstructed, pull the  button down again to the point of resistance until the sliding sunroof is closed. The sliding sunroof will be closed without the automatic reversing function.

## Anti-theft prevention

### Function of immobiliser

The immobiliser prevents your vehicle from being started without the correct key.

The immobiliser is automatically activated when the vehicle is switched off, and deactivated when the vehicle is switched on.

## ATA (Anti-Theft Alarm system)

### Function of ATA (Anti-theft Alarm system)

If the ATA system is primed, a visual and audible alarm is triggered in the following situations:

- when opening a door
- when opening the vehicle with the emergency key
- when opening the bonnet
- when opening the tailgate

After locking the vehicle with the key, the ATA system is automatically primed.



When the ATA system is primed, indicator lamp **①** flashes in the overhead control panel.

ATA is automatically deactivated in the following situations:

- After unlocking the vehicle with the key.
- When the key is inserted into the ignition lock.

**i** The alarm is not deactivated, even if you immediately close the open door that has triggered it, for example.

### Priming/deactivating ATA (Anti-theft Alarm system)

#### Activating



- ▶ Close all the doors.
- ▶ Lock the vehicle with the key. Indicator lamp **①** in the overhead control panel flashes.

**Deactivating**

▶ Unlock the vehicle with the key.  
or

▶ Insert the key into the ignition lock.  
Indicator lamp ① in the overhead control panel goes out.

**Stopping the alarm**

▶ Press the  or  button on the key.  
or

▶ Insert the key into the ignition lock.  
The alarm stops.

**Function of tow-away protection**

A visual and audible alarm is triggered if the inclination of the vehicle changes, e.g. when lifted on one side, and tow-away protection is primed.

**Priming/deactivating tow-away protection****Requirements:**

- The doors are closed.
- The tailgate is closed.

**Activating**

▶ Lock the vehicle with the key.  
Tow-away protection is automatically primed after about 50 seconds.

**Deactivating**

▶ Open the vehicle with the key.  
or

▶ Insert the key into the ignition lock.  
Tow-away protection is deactivated.

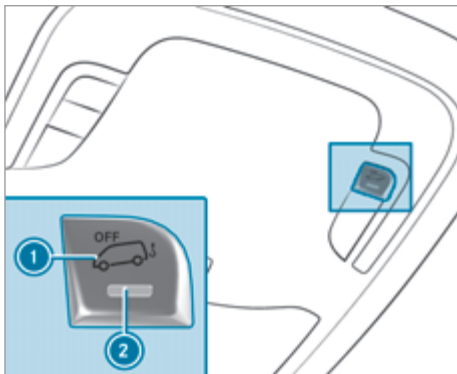
**Deactivating**

▶ Remove the key from the ignition lock.

▶ Press button ①.  
When the button is released, indicator lamp ② in the button lights up for approximately three seconds.

▶ Lock the vehicle with the key.  
Tow-away protection is deactivated.

Tow-away protection remains deactivated until you lock the vehicle again.

In the following situations, a false alarm can occur:

- when loading and/or transporting the vehicle on a ferry or car transporter, for example
- when parking the vehicle on a movable surface, such as a split-level garage

Deactivate tow-away protection in these situations.

**Function of interior protection**

If the primed interior motion sensor detects motion in the vehicle interior, a visual and acoustic alarm is triggered. This can happen if someone reaches into the vehicle interior, for example.

**Priming and deactivating the interior motion sensor****Requirements:**

- The side windows are closed.
- The doors are closed.
- The tailgate is closed.

**Priming**

▶ Make sure that nothing (such as mascots or coat hangers) is hanging on the rear-view mirror or on the grab handles. This will prevent false alarms.

▶ Lock the vehicle with the key.  
The interior motion sensor is primed after approximately 20 seconds.

**Deactivating**

▶ Unlock the vehicle with the key.

or

▶ Insert the key into the ignition lock.  
The interior motion sensor automatically switches off.

## Deactivating

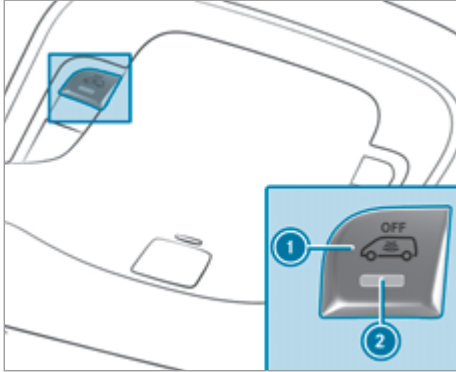

- ▶ Remove the key from the ignition lock.
- ▶ Press button ①.  
When the button is released, indicator lamp ② in the button lights up for approximately three seconds.
- ▶ Lock the vehicle with the key.  
The interior motion sensor is deactivated.

Interior protection remains deactivated until you lock the vehicle again.

In the following situations, a false alarm can occur:

- if there are people or animals remaining inside
- when transporting the vehicle on a ferry or car transporter, for example

Deactivate the interior motion sensor in these situations.

### Notes on the correct driver's seat position

- ⚠ WARNING** Risk of accident due to adjusting the vehicle settings while the vehicle is in motion

You could lose control of the vehicle in the following situations in particular:

- if you adjust the driver's seat, the head restraint, the steering wheel or the mirror while the vehicle is in motion
- if you fasten your seat belt while the vehicle is in motion

▶ Before starting the vehicle: in particular, adjust the driver's seat, head restraint, steering wheel and mirror, and fasten your seat belt.



Ensure the following when adjusting steering wheel ③, seat belt ② and driver's seat ①:

- You are sitting as far away from the driver's air-bag as possible.
- You are sitting in an upright position.
- Your thighs are gently supported by the seat cushion.
- Your legs are not fully extended and you can reach the pedals easily.
- The back of your head is supported at eye level by the middle part of the head restraint.
- You can hold the steering wheel with your arms slightly bent.
- You can move your legs without any restrictions.
- You can see all of the instrument cluster displays well.

- You have a good overview of the traffic conditions.
- Your seat belt sits snugly against your body and passes across the centre of your shoulder and across your hips in the pelvic area.

### Seats

#### Adjusting the front seat mechanically

- ⚠ WARNING** Risk of becoming trapped if the seat is adjusted by children

Children could become trapped if they adjust the seats, particularly if they are unattended.

- ▶ When leaving the vehicle, always take the key with you and lock the vehicle.
- ▶ Never leave children unattended in the vehicle.

- ⚠ WARNING** Risk of accident due to adjusting the vehicle settings while the vehicle is in motion

You could lose control of the vehicle in the following situations in particular:

- if you adjust the driver's seat, the head restraint, the steering wheel or the mirror while the vehicle is in motion
- if you fasten your seat belt while the vehicle is in motion

▶ Before starting the vehicle: in particular, adjust the driver's seat, head restraint, steering wheel and mirror, and fasten your seat belt.

- ⚠ WARNING** Risk of becoming trapped during seat adjustment

When you adjust a seat, you or other vehicle occupants could become trapped, e.g. on the seat guide rail.

- ▶ Make sure when adjusting a seat that no one has any body parts in the sweep of the seat.

Observe the safety notes on "Airbags" and "Children in the vehicle".

- ⚠ WARNING** Risk of accident due to the driver's seat not being engaged

The driver's seat may move unexpectedly while driving.

This could cause you to lose control of the vehicle.

- ▶ Always make sure that the driver's seat is engaged before starting the vehicle.

**⚠ WARNING** Risk of injury or death due to the front seat being positioned too close to the cockpit

The front airbags can also injure the occupants in the front of the vehicle.

- ▶ Always adjust the front seats so they are as far away as possible from the front airbags.
- ▶ In addition, observe the notes on correct seat adjustment.

**⚠ WARNING** Risk of injury or death due to incorrect seat position

The seat belt will not offer the intended level of protection if you have not moved the seat backrest to an almost vertical position.

In particular, you may slip under the seatbelt and injure yourself.

- ▶ Adjust the seat properly before beginning your journey.
- ▶ Always ensure that the seat backrest is in an almost vertical position and that the shoulder section of your seat belt is routed across the centre of your shoulder.

**⚠ WARNING** Risk of injury due to head restraints not being fitted or being adjusted incorrectly

If head restraints have not been installed or have not been adjusted correctly, there is an increased risk of injury in the head and neck area, e.g. in the event of an accident or when braking.

- ▶ Always drive with the head restraints fitted.
- ▶ Before driving off, make sure for every vehicle occupant that the centre of the head restraint supports the back of the head at about eye level.

Do not interchange the head restraints of the front and rear seats. Otherwise, you will not be able to set the height and inclination of the head restraints to the correct position.

Adjust the head restraint fore-and-aft position so that it is as close as possible to the back of your head.

**⚠ WARNING** Risk of burns from hot amplifiers under the driver's seat

Vehicles with amplifiers under the driver's seat: The amplifier can become hot during operation.

You could burn yourself if you touch the amplifier.

- ▶ Do not reach underneath the driver's seat.
- ▶ Adjust the driver's seat carefully.

**⚠ NOTE** Damage to the seats and seat heating due to fluids, sharp objects or insulating materials

To prevent damage to the seats and the seat heating, observe the following instructions:

- ▶ Do not spill any fluids onto the seats. If something is spilt onto the seats, dry the seats as quickly as possible.
- ▶ Do not switch on the seat heating if the seat covers are wet or damp. Do not use the seat heating to dry the seats.
- ▶ Clean the seats as recommended; see the "Cleaning and care" section.
- ▶ Do not transport heavy loads on the seats. Do not place any sharp objects, such as knives, nails or tools, on the seats. If possible, use the seats only for people.
- ▶ When using the seat heating, do not cover the seats with insulating materials, such as blankets, coats, bags, protective covers, child seats or booster seats.

### Adjusting the seat fore-and-aft position

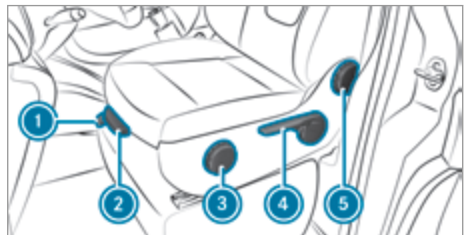

- ▶ Pull lever ① upwards and slide the seat forwards or back until the desired position has been reached.
- ▶ Release lever ① and push the seat back or forwards until you hear the seat engage.
- ① For front swivel seats, the lever in position ① is used to release the swivel seat. The lever to adjust the fore-and-aft position is in the form of a bar in front of the seat (→ page 77).

### Adjusting the seat height

- ▶ Pull or push lever ④ repeatedly until the desired seat height has been reached.

### Adjusting the seat backrest

- ▶ Turn handwheel ⑤ forwards.  
The seat backrest will move to a vertical position.
- ▶ Turn handwheel ⑤ backwards.  
The seat backrest will tilt back.

### Adjusting the seat cushion inclination

- ▶ Turn handwheel ③ forwards.  
The front of the seat cushion will tilt down.
- ▶ Turn handwheel ③ backwards.  
The front of the seat cushion will tilt up.

### Adjusting the seat cushion length

- ▶ Pull lever ② upwards and slide the front part of the seat cushion forwards or backwards.

### Adjusting the front seat electrically

- ⚠ **WARNING** Risk of becoming trapped if the seat is adjusted by children

Children could become trapped if they adjust the seats, particularly if they are unattended.

- ▶ When leaving the vehicle, always take the key with you and lock the vehicle.
- ▶ Never leave children unattended in the vehicle.

The seats can be adjusted when there is no key in the ignition lock.

- ⚠ **WARNING** Risk of accident due to adjusting the vehicle settings while the vehicle is in motion

You could lose control of the vehicle in the following situations in particular:

- if you adjust the driver's seat, the head restraint, the steering wheel or the mirror while the vehicle is in motion
- if you fasten your seat belt while the vehicle is in motion

- ▶ Before starting the vehicle: in particular, adjust the driver's seat, head restraint, steering wheel and mirror, and fasten your seat belt.

- ⚠ **WARNING** Risk of becoming trapped during seat adjustment

When you adjust a seat, you or other vehicle occupants could become trapped, e.g. on the seat guide rail.

- ▶ Make sure when adjusting a seat that no one has any body parts in the sweep of the seat.

Observe the safety notes on "Airbags" and "Children in the vehicle".

- ⚠ **WARNING** Risk of injury or death due to the front seat being positioned too close to the cockpit

The front airbags can also injure the occupants in the front of the vehicle.

- ▶ Always adjust the front seats so they are as far away as possible from the front airbags.
- ▶ In addition, observe the notes on correct seat adjustment.

- ⚠ **WARNING** Risk of injury or death due to incorrect seat position

The seat belt will not offer the intended level of protection if you have not moved the seat backrest to an almost vertical position.

In particular, you may slip under the seatbelt and injure yourself.

- ▶ Adjust the seat properly before beginning your journey.
- ▶ Always ensure that the seat backrest is in an almost vertical position and that

the shoulder section of your seat belt is routed across the centre of your shoulder.

**⚠ WARNING** Risk of injury due to head restraints not being fitted or being adjusted incorrectly

If head restraints have not been installed or have not been adjusted correctly, there is an increased risk of injury in the head and neck area, e.g. in the event of an accident or when braking.

- ▶ Always drive with the head restraints fitted.
- ▶ Before driving off, make sure for every vehicle occupant that the centre of the head restraint supports the back of the head at about eye level.

Do not interchange the head restraints of the front and rear seats. Otherwise, you will not be able to set the height and inclination of the head restraints to the correct position.

Adjust the head restraint fore-and-aft position so that it is as close as possible to the back of your head.

**⚠ WARNING** Risk of burns from hot amplifiers under the driver's seat

Vehicles with amplifiers under the driver's seat: The amplifier can become hot during operation.

You could burn yourself if you touch the amplifier.

- ▶ Do not reach underneath the driver's seat.
- ▶ Adjust the driver's seat carefully.

**! NOTE** Damage to the seats and seat heating due to fluids, sharp objects or insulating materials

To prevent damage to the seats and the seat heating, observe the following instructions:

- ▶ Do not spill any fluids onto the seats. If something is spilt onto the seats, dry the seats as quickly as possible.
- ▶ Do not switch on the seat heating if the seat covers are wet or damp. Do not use the seat heating to dry the seats.

- ▶ Clean the seats as recommended; see the "Cleaning and care" section.
- ▶ Do not transport heavy loads on the seats. Do not place any sharp objects, such as knives, nails or tools, on the seats. If possible, use the seats only for people.
- ▶ When using the seat heating, do not cover the seats with insulating materials, such as blankets, coats, bags, protective covers, child seats or booster seats.

#### Requirements:

- The vehicle is switched on or the door is open.

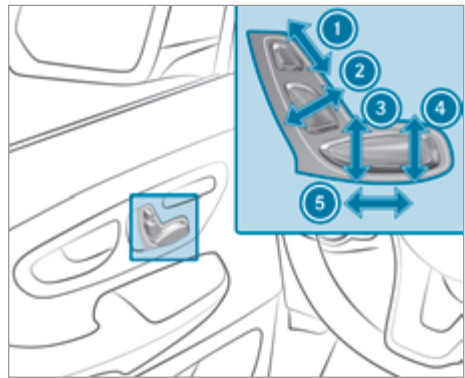

- ① Head restraint height adjustment
- ② Seat backrest inclination adjustment
- ③ Seat height adjustment
- ④ Seat cushion inclination adjustment
- ⑤ Seat fore-and-aft position adjustment

- ▶ Adjust the seat using buttons ① to ⑤ on the door trim.

If the vehicle is not switched on, you can adjust the seat within 30 seconds of unlocking the vehicle.

- ① **Vehicles with PRE-SAFE®:** if PRE-SAFE® intervenes, the front passenger seat will automatically be adjusted from a less favourable position into one that offers better protection. The front passenger seat can be readjusted only after the hazardous situation is over. Information about the system can be found under "PRE-SAFE® System" (→ page 39).
- ① You can save the settings for the seat with the memory function (→ page 76).

### Setting 4-way lumbar support

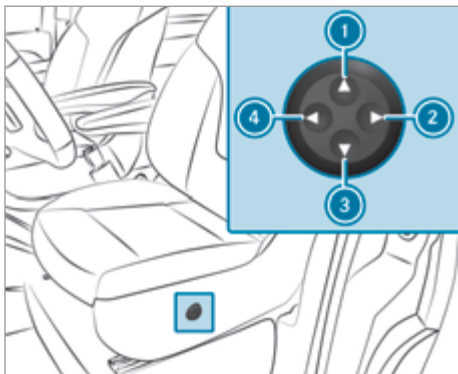

- ① Higher
- ② Weaker
- ③ Lower
- ④ Stronger

► Use buttons ① to ④ adjust the backrest contour individually to your spine.

### Operating the memory function

**⚠ WARNING** Risk of an accident if the memory function is used while driving

If you use the memory function on the driver's side while driving, you could lose control of the vehicle as a result of the adjustments being made.

► Only use the memory function on the driver's side when the vehicle is stationary.

**⚠ WARNING** Risk of entrapment when adjusting the seat with the memory function

When the memory function adjusts the seat, you and other vehicle occupants – particularly children – could become trapped.

► During the adjustment process of the memory function, make sure that no one has any body parts in the sweep of the seat.

► If somebody becomes trapped, immediately release the memory function position button.  
The adjustment process is stopped.

**⚠ WARNING** Risk of entrapment if the memory function is activated by children

Children could become trapped if they activate the memory function, particularly when unattended.

- Never leave children unattended in the vehicle.
- When leaving the vehicle, always take the key with you and lock the vehicle.

The memory function can be used when the vehicle is switched off.

**! NOTE** Damage to the seat when moving into a stored position

If the seat is moved out of the fully reclined position into a stored seat position, it can collide with other vehicle parts.

This can damage the seat.

► Before moving the seat into a stored position, move the seat backrest into an upright position.

### Storing seat settings

**i Vehicles with luxury rear seat:** the memory function is used identically to the front seats. Two memory positions are available.

Seat settings for up to three people can be stored and called up using the memory function.

The following settings are stored as a single memory preset:

- the position of the seat, seat backrest and head restraint
- additionally for the driver's side, the position of both exterior mirrors

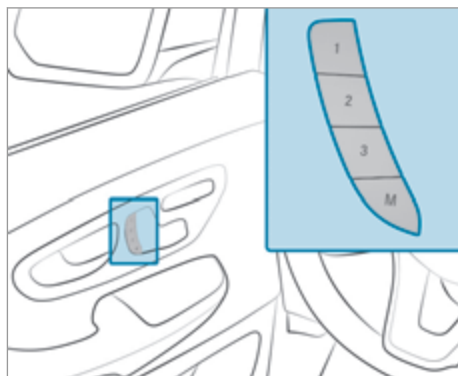

- ▶ Adjust the seat to the desired position.
- ▶ Adjust the exterior mirror to the desired position.
- ▶ Briefly press memory button **M** and then press preset position button **1**, **2** or **3** within three seconds. An acoustic signal sounds. The settings are stored.
- ▶ **To call up:** press and hold preset position button **1**, **2** or **3** until the seat and the exterior mirrors are in the stored position.

### Rotating the front seats

**⚠ WARNING** Risk of injury or fatal injuries if the driver's seat and front passenger seat are not engaged

In this situation, the restraint systems cannot perform their intended protective function.

- ▶ Engage the driver's seat and front passenger seat in the direction of travel before you start the vehicle.

**! NOTE** Damage to the seats due to colliding with adjacent car parts

When you rotate the seats, they may collide with adjacent car parts.

This can damage the seats.

- ▶ When you rotate the seats, make sure there is sufficient clearance.

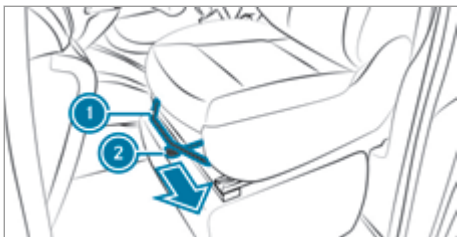

You can rotate the driver's and front passenger seats by 50° and 180°. The seats engage both in and opposite to the direction of travel as well as at 50° towards the exit.

- ▶ When you rotate the seat, open the respective front door to avoid a collision with the door trim.

- ▶ Adjust the steering wheel in such a way that there is sufficient clearance to rotate and adjust the driver's seat (→ page 100).
- ▶ Push lever **1** in the direction of the arrow. The turning device will be unlocked.
- ▶ Rotate the seat in the desired direction.
- ▶ If there is a risk of collision with the centre console or the B-pillar, pull lever **2** upwards and move the front seat forwards or backwards into the desired position. Then release lever **2**.
- ▶ In the desired position, make sure that the seat has engaged in the direction of rotation and the longitudinal direction.

### Adjusting armrests

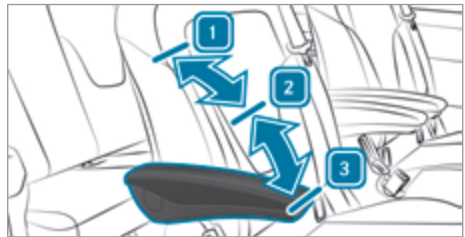

- ▶ Fold the armrest upwards more than 45° in position **2**. The armrest will be unlocked.
- ▶ Fold the armrest forwards **3** as far as it will go.
- ▶ Slowly fold the armrest upwards into the required position.
- ▶ **To fold the armrest upwards:** if necessary, fold the armrest upwards more than 90° in position **1**.

### Rear seats and rear bench seat

#### Notes on the rear seats

Your vehicle may be equipped with the following seats and bench seats in the rear compartment:

- Standard rear seat
- Luxury rear seat
- Comfort rear bench seat
- Seat/bunk combination

## Bench seat anchorage

**⚠ WARNING** Risk of accident- and injury if the seat is not engaged

If a seat is not engaged, it may be thrown about while the vehicle is moving.

- ▶ Always make sure that all seats are engaged as described.

**⚠ WARNING** Risk of accident and injury as a result of rear bench seat not being engaged

If the rear bench seat is not engaged, it may be flung around during travel.

- ▶ Always make sure that the rear bench seat is engaged as described.

Keep the seat anchorages in the vehicle floor free of dirt and objects at all times to ensure that the seat engages securely.

If the indicator tab of the seat anchorages is not retracted into the seat leg, the seat is not correctly engaged. Engage the seat again.

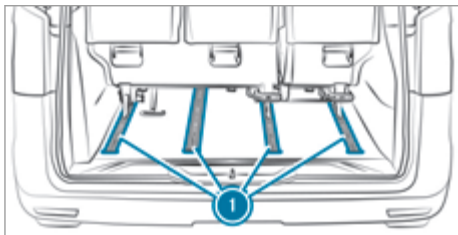

Example: seat rail system with quick-locking mechanism

Guide rails ① of the seat rail system can be used for the following purposes:

- For mounting up to two rear seat rows
- For mounting both rear seat rows facing one another
- For mounting rear seats and rear bench seats
- For moving rear seats and rear bench seats

**i** When you remove a rear bench seat or a seat, the seat slider may slide into a guide rail. The seat sliders will then no longer be parallel in the guide rails. In this case, you will no longer be able to fit the respective seating. The seat sliders must be moved only using a special tool or at a qualified specialist workshop in order to prevent the risk of damage. The tool

is available as a Mercedes-Benz accessory or as part of a seat/bunk combination.

## Seating variants

**⚠ WARNING** Risk of injury due to incorrect installation of the rear bench seats

If the rear bench seats are incorrectly installed, the integrated safety precautions in the rear bench seats cannot work as intended.

- ▶ Install the rear bench seats only as described.
- ▶ Only use rear bench seats approved for your vehicle.

Depending on the type of seat anchorage in the vehicle floor, you can install the following seating variants:

- Rear bench seats with two or three seats
- Single rear seats
- Seat/bunk combination with three seats

Depending on the vehicle equipment, you can fit the rear bench seats and the rear seats on the first and/or second rear seat row.

The seating variants shown are permitted only if the conditions specified below for safe rear seating are met. Other seating variants are not permitted and may endanger the occupants.

When only the individual seats are used, the rear seats can be installed facing in the direction of travel in all combinations and configurations.

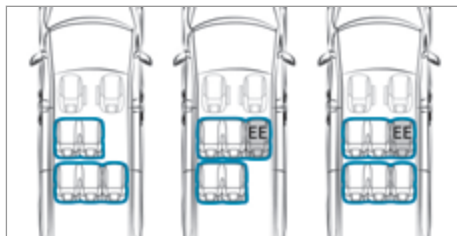
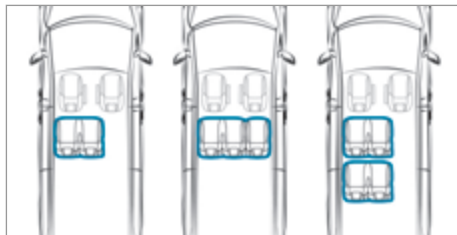

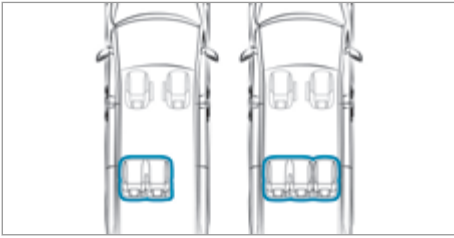

Seating variants facing in the direction of travel

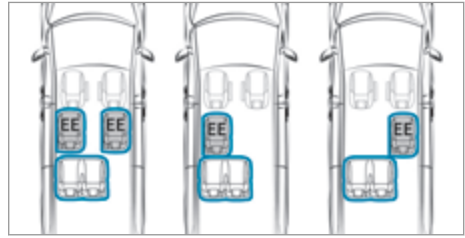

Seating variants for the rear seats and rear bench seats facing in the direction of travel

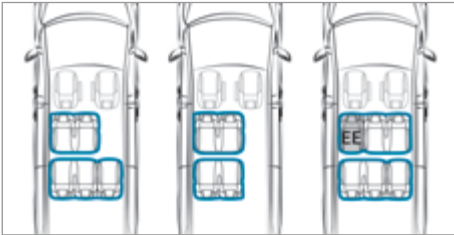

Seating variants for the rear bench seats in the face-to-face position

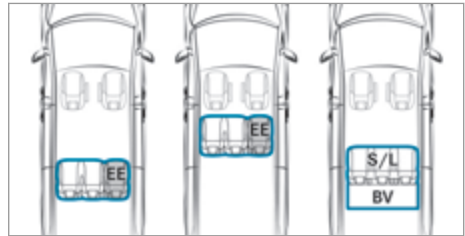
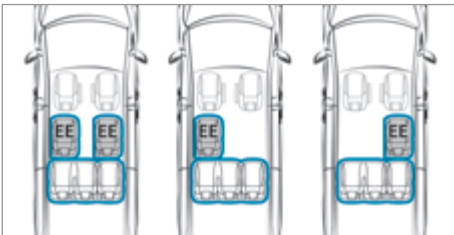
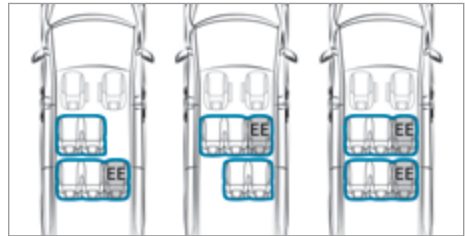
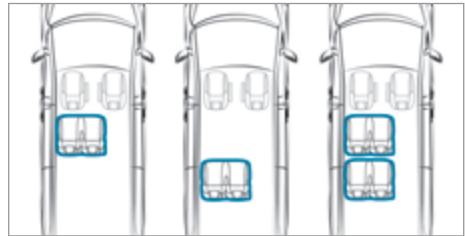

Seating variants for the rear bench seats facing in the direction of travel

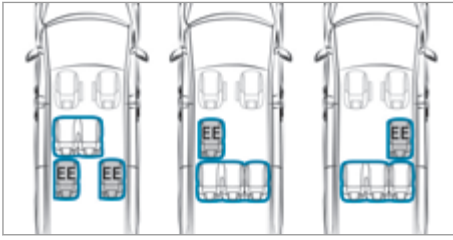

Seating variants for the rear seats and rear bench seats facing in the direction of travel, part 1



Seating variants in the face-to-face position, part 1

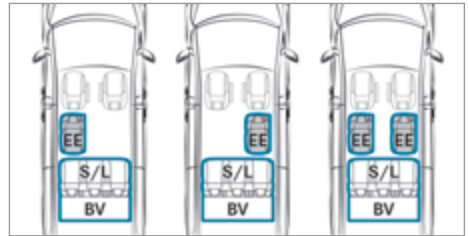
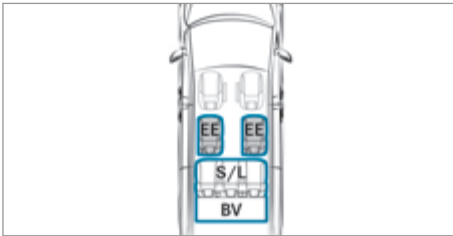
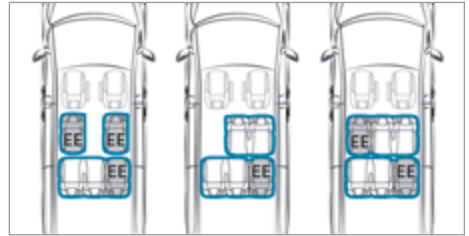
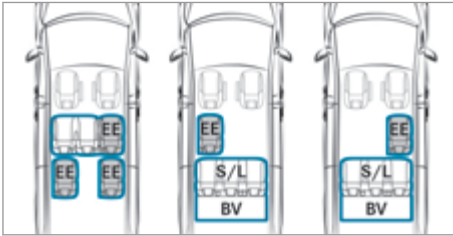
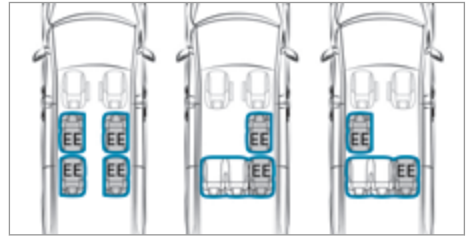
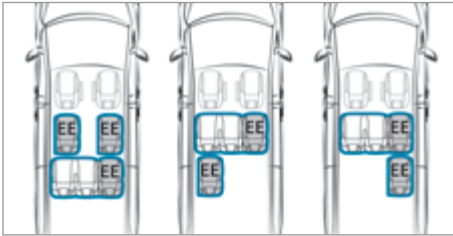

Seating variants for the rear seats and rear bench seats facing in the direction of travel, part 2

Seating variants in the face-to-face position, part 2



EE Easy entry and exit feature – EASY-ENTRY

S/L Seat/bunk combination

BV Bed extension

If a rear bench seat or rear seat is marked with EE in the illustrations, a rear bench seat or rear seat with the EASY-ENTRY easy entry and exit feature must be fitted in the position indicated.

If a rear bench seat is not marked, a rear bench seat with or without the EASY-ENTRY feature can be fitted in the position indicated.

Please observe the following conditions for safe rear seating:

- Use only rear seats and rear bench seats approved for your vehicle.
- A rear seat or rear bench seat may be fitted facing the rear only if each seat has a seat opposite it – face-to-face position.
- Fit luxury rear seats on the first rear seat row and in the direction of travel only.
- Vehicles with a seat rail system in the vehicle floor:
  - The seat/bunk combination (S/L) may not be installed in combination with bench seats.
  - Passengers may use the seats only if the rear seat and/or rear bench seat has engaged correctly (→ page 82).

### Using the EASY-ENTRY easy entry and exit feature (rear bench seat)

**⚠ WARNING** Risk of accident and injury as a result of rear bench seat not being engaged

If the rear bench seat is not engaged, it may be flung around during travel.

- ▶ Always make sure that the rear bench seat is engaged as described.

In order to ensure that the rear bench seat can securely engage, keep the seat guide rails and anchorages in the vehicle floor free of dirt and foreign objects.

If the indicator tab of the seat anchorage is not retracted into the seat leg, the seat is not correctly engaged. Engage the seat again.

**⚠ WARNING** Risk of becoming trapped when adjusting the rear bench seat

When adjusting a rear bench seat, you or another vehicle occupant could become trapped by the guide rail of the rear bench seat, for example.

- ▶ Make sure that no one has any part of their body within the sweep of the rear bench seat when adjusting it.

**⚠ WARNING** Risk of becoming trapped due to the rear bench seat not being engaged

The rear bench seat will not engage when folded forward. The rear bench seat may inadvertently fold back while the vehicle is accelerating, braking or changing direction suddenly or in the event of an accident, for example.

People within the sweep of the rear bench seat may become trapped.

- ▶ Always fold back a rear bench seat that has been folded forward before you start driving.
- ▶ Ensure that the rear bench seat is engaged.

### Folding the EASY-ENTRY section forwards/back

If you fold the EASY-ENTRY section of the rear bench seat forwards, it is easier for you to get in and out of the vehicle.

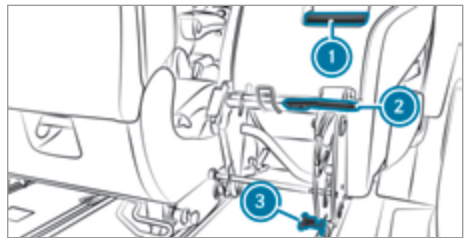

Rear bench seat with EASY-ENTRY feature (example: comfort rear bench seat)

- ① Grab handle
- ② EASY-ENTRY release handle
- ③ Release handle for front seat legs

- ▶ Pull EASY-ENTRY release handle ② upwards.
- ▶ Fold the EASY-ENTRY section forwards with the aid of grab handle ①.

▶ **To fold the EASY-ENTRY section back:** fold the EASY-ENTRY section back until it engages in the seat anchorages. The indicator tab will no longer be visible.

- ⓘ The EASY-ENTRY section is correctly engaged when the seat leg engages audibly and the indicator tab is no longer visible and is fully retracted into the seat leg.

### Removing the EASY-ENTRY section

- ▶ **Vehicles with comfort rear bench seat:** fold the seat backrest forward.
- ▶ Pull EASY-ENTRY release handle ② upwards.

- ▶ Fold the EASY-ENTRY section forwards with the aid of grab handle ❶.
- ▶ Pull release handle ❸ for the front seat legs upwards.
- ▶ Fold the EASY-ENTRY section further forwards.
- ▶ Lift the EASY-ENTRY section up and out of the anchorage.

### Installing the EASY-ENTRY section

- ▶ Place and engage the front seat leg of the EASY-ENTRY section on the seat anchorages.
- ▶ Fold the EASY-ENTRY section back. The rear seat leg of the EASY-ENTRY section will engage audibly. The indicator tab on the seat leg will no longer be visible.

❶ The EASY-ENTRY section is correctly engaged when the seat leg engages audibly and the indicator tab is no longer visible and is fully retracted into the seat leg.

- ▶ **Vehicles with comfort rear bench seat:** fold the seat backrest back to the seat position.

### Adjusting the seat backrest (comfort rear bench seat)

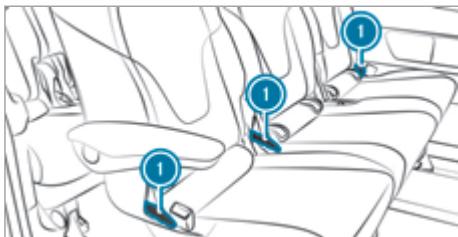

Only the seat backrests of a comfort rear bench seat can be adjusted.

- ▶ Pull release handle ❶ for the seat backrest upwards and hold it in position.
- ▶ Move the seat backrest to the desired position.
- ▶ Let go of release handle ❶ for the seat backrest and move the seat backrest slightly. The seat backrest will engage in position.

### Moving the rear bench seat

**⚠ WARNING** Risk of becoming trapped when adjusting the rear bench seat

When adjusting a rear bench seat, you or another vehicle occupant could become trapped by the guide rail of the rear bench seat, for example.

- ▶ Make sure that no one has any part of their body within the sweep of the rear bench seat when adjusting it.

**⚠ WARNING** Risk of injury due to moving the rear bench seat while the vehicle is in motion

If you move the rear bench seat while driving, the seat may move in an unexpected or jerking manner, for instance when braking.

You could become trapped as well as thrown against parts of the vehicle or other vehicle occupants.

- ▶ Only move the rear bench seat when the vehicle is stationary.
- ▶ Make sure that the rear bench seat is engaged after it is moved.

**⚠ WARNING** Risk of injury due to no protective effect from the window airbag

If you move the seat position outside the marked area, the window airbag can no longer provide optimum protection.

The protective effect of the window airbag is gradually reduced and may in some positions no longer be provided at all.

- ▶ Engage the rear seats or the rear bench seat on the guide rail within the marked area.

**⚠ WARNING** Risk of injury from the front seat being positioned too close to vehicle occupants

If you move the rear seats or the rear bench seat outside the markings on the guide rail, this could result in the passenger striking their head on the front seat.

- ▶ Maintain a minimum clearance of 5 cm between the knees of the respective vehicle occupants and the seat in front of them.

**Requirements**

- The vehicle is equipped with a seat rail system in the vehicle floor.

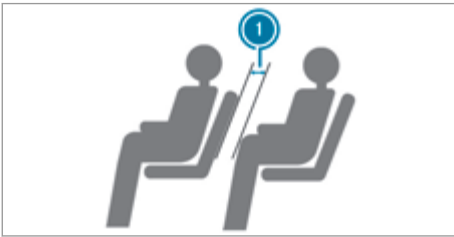

Maintain a minimum clearance of 5 cm **1** between the knees of the vehicle occupants and the seat in front of them.

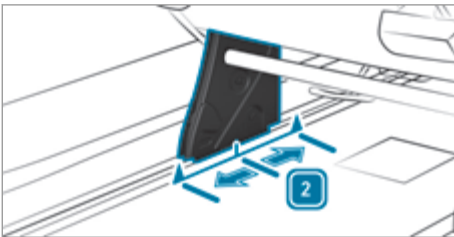

Starting from the basic setting **2**, the rear bench seat for passengers can be moved forwards or backwards by 5 cm. In doing so, make sure that passengers have sufficient legroom to reduce the risk of injury during braking.

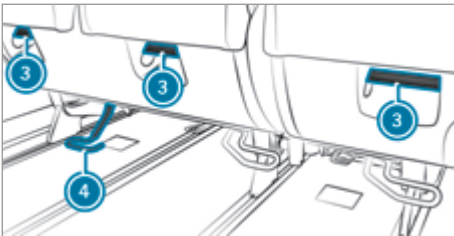

You can slide the rear bench seat only when it is unoccupied. If possible, slide the rear bench seat with the assistance of a second person.

- ▶ Pull up release handle **4** for seat fore-and-aft adjustment.
- ▶ Move the rear bench seat to the desired position by grab handles **3**.
- ▶ Let go of release handle **4**. Release handle **4** will fold down to its original position.

- ▶ Make sure that all sliders for fore-and-aft adjustment engage audibly on both sides. It will no longer be possible to move the rear bench seat.

**Folding the rear bench seat forwards and backwards**

- ⚠ WARNING** Risk of accident and injury as a result of rear bench seat not being engaged

If the rear bench seat is not engaged, it may be flung around during travel.

- ▶ Always make sure that the rear bench seat is engaged as described.

To ensure that the rear bench seat engages securely, keep the seat guide rails and anchorages in the vehicle floor free from dirt and foreign objects.

If the indicator tab of the seat anchorage is not retracted into the seat leg, the seat is not correctly engaged. Engage the seat again.

- ⚠ WARNING** Risk of becoming trapped due to the rear bench seat not being engaged

The rear bench seat will not engage when folded forward. The rear bench seat may inadvertently fold back while the vehicle is accelerating, braking or changing direction suddenly or in the event of an accident, for example.

People within the sweep of the rear bench seat may become trapped.

- ▶ Always fold back a rear bench seat that has been folded forward before you start driving.
- ▶ Ensure that the rear bench seat is engaged.

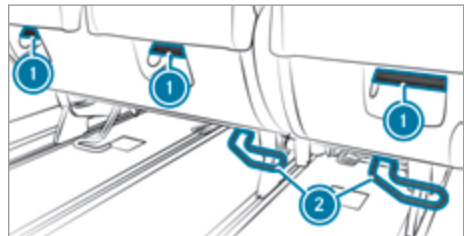

- ▶ Remove the head restraints (→ page 96).
- ▶ Vehicles with luxury rear bench seat: fold the seat backrest forwards (→ page 82).

- ▶ Pull the release handles for rear seat anchorage ② up and tilt the rear bench seat.
- ▶ Grasp the rear bench seat by grab handles ① and fold the seat forwards.

### Installing and removing the comfort rear bench seat

**⚠ WARNING** Risk of accident and injury as a result of rear bench seat not being engaged

If the rear bench seat is not engaged, it may be flung around during travel.

- ▶ Always make sure that the rear bench seat is engaged as described.

Keep the seat anchorages in the vehicle floor free of dirt and objects at all times to ensure that the rear bench seat engages securely.

If the indicator tab of the seat anchorage is not retracted into the seat leg, the seat is not correctly engaged. Engage the seat again.

### Removing the rear bench seat

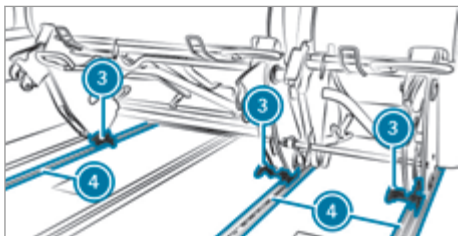
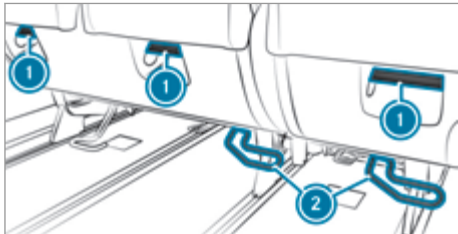

- ① In vehicles with a seat rail system, carry out the release, removal and subsequent reinstallation of the rear bench seats at the marked basic position only (→ page 82).

- ▶ Make sure that all sliders for fore-and-aft adjustment are engaged on both sides. It should not be possible to move the rear bench seat.

- ▶ Fold the rear bench seat forwards (→ page 83).
- ▶ Pull release handle ③ upwards.
- ▶ Grasp the rear bench seat by grab handles ① and lift it out of seat anchorages ④.

- ① If the second rear seat row is to be removed or tilted, the seat or bench seat in the first rear seat row must first be tilted forward to avoid damage to the seats.

### Installing the rear bench seat

- ▶ Grasp the rear bench seat by grab handles ① and insert it into front seat anchorages ④ from the front and above at an angle.
- ▶ Tilt the rear bench seat back and allow it to engage. Release handles ② fold down towards the vehicle floor.
- ▶ Fold the rear bench seat back into the seat position.

The rear seat legs of the rear bench seat are correctly engaged when the seat legs engage audibly and the indicator tabs on the seat legs are no longer visible and have fully retracted into the seat legs.

- ▶ Slide the rear bench seat into the basic setting (→ page 82).

### Using the EASY-ENTRY easy entry and exit feature (rear seat)

**⚠ WARNING** Risk of accident- and injury if the seat is not engaged

If a seat is not engaged, it may be thrown about while the vehicle is moving.

- ▶ Always make sure that all seats are engaged as described.

In order to ensure that the seats can securely engage, keep the seat guide rails and anchorages in the vehicle floor free of dirt and foreign objects.

If the indicator tab of the seat anchorage is not retracted into the seat leg, the seat is not correctly engaged. Engage the seat again.

**⚠ WARNING** Risk of becoming trapped when adjusting the seats

When you adjust a seat, you may trap yourself or a vehicle occupant.

- ▶ When adjusting a seat, make sure that no one has any body parts in the sweep of the seat.

**⚠ WARNING** Risk of becoming trapped if the seat is not engaged

The seat does not engage when folded forwards. The seat can fold backwards unexpectedly, e.g. when accelerating, braking or in the event of an abrupt change of direction or an accident.

People in the seat's sweep can become trapped.

- ▶ If a seat is folded forwards, always fold it back before driving off.
- ▶ Make sure that the seat is engaged.

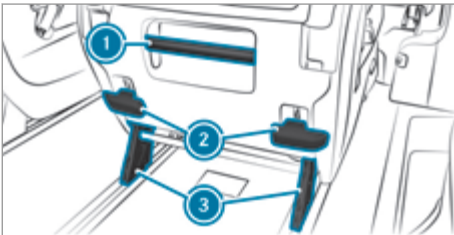

If you fold the rear seat forwards, it is easier for you to get in and out of the vehicle.

- ▶ **To fold the rear seat forwards:** pull one of the two EASY-ENTRY release handles ② upwards and fold the rear seat forwards.
- ▶ **To fold the rear seat back:** fold the rear seat back using grab handle ① until it engages in the seat anchorages. Indicator tab ③ will no longer be visible and will be fully retracted into the seat leg.

### Adjusting the seat backrest (rear seat)



- ▶ Pull the release handle for seat backrest ① upwards and hold it in position.

- ▶ Move the seat backrest to the desired position.
- ▶ Let go of release handle ① for the seat backrest and move the seat backrest slightly. The seat backrest will engage in position.

### Moving the rear seat

**⚠ WARNING** Risk of becoming trapped when adjusting the seats

When you adjust a seat, you may trap yourself or a vehicle occupant.

- ▶ When adjusting a seat, make sure that no one has any body parts in the sweep of the seat.

**⚠ WARNING** Risk of injury due to moving the rear seat while the vehicle is in motion

If you move a rear seat while driving, the seat may move in an unexpected or jerking manner, for instance when braking.

You could become trapped as well as thrown against parts of the vehicle or other vehicle occupants.

- ▶ Move a rear seat only when the vehicle is stationary.
- ▶ Make sure that the rear seat is engaged after it is moved.

**⚠ WARNING** Risk of injury due to no protective effect from the window airbag

If you move the seat position outside the marked area, the window airbag can no longer provide optimum protection.

The protective effect of the window airbag is gradually reduced and may in some positions no longer be provided at all.

- ▶ Engage the rear seats or the rear bench seat on the guide rail within the marked area.

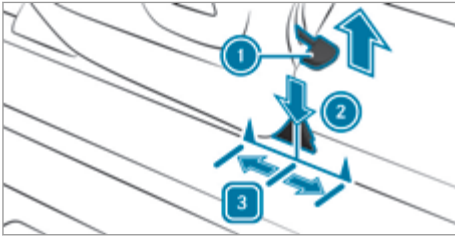

- ① Release handle for seat fore-and-aft adjustment
- ② Fore-and-aft setting marking
- ③ Basic setting marking

Starting from the basic setting ③, the rear seats for passengers can be moved forwards or backwards by 5 cm. In doing so, make sure that passengers have sufficient legroom to reduce the risk of injury during braking.

- ▶ Pull release handle ① in the direction of the arrow.
- ▶ With the release handle pulled, slide the rear seat to the desired position.
- ▶ Release the release handle ①.
- ▶ Slide the rear seat forwards and backwards until the carriage is correctly engaged on both sides.  
It should not be possible to move the seat.

### Folding the rear seat forwards and backwards

**⚠ WARNING** Risk of becoming trapped when adjusting the seats

When you adjust a seat, you may trap yourself or a vehicle occupant.

- ▶ When adjusting a seat, make sure that no one has any body parts in the sweep of the seat.

**⚠ WARNING** Risk of accident- and injury if the seat is not engaged

If a seat is not engaged, it may be thrown about while the vehicle is moving.

- ▶ Always make sure that all seats are engaged as described.

In order to ensure that the seats can securely engage, keep the seat guide rails and anchorages in the vehicle floor free of dirt and foreign objects.

If the indicator tab of the seat anchorage is not retracted into the seat leg, the seat is not correctly engaged. Engage the seat again.

**⚠ WARNING** Risk of becoming trapped if the seat is not engaged

The seat does not engage when folded forwards. The seat can fold backwards unexpectedly, e.g. when accelerating, braking or in the event of an abrupt change of direction or an accident.

People in the seat's sweep can become trapped.

- ▶ If a seat is folded forwards, always fold it back before driving off.
- ▶ Make sure that the seat is engaged.

**! NOTE** Damage to the folding table or the armrest when the rear seats are folded forwards or backwards

If the folding table is not positioned all the way back when the rear seats are folded forwards or backwards, the folding table and/or the armrest of the rear seat may be damaged.

- ▶ Slide the folding table all the way back before folding the rear seats forwards or backwards.

**! NOTE** Damage to the cup holder from the rear seat

Folding the rear seat in the third row of seats forwards can damage the cup holder.

- ▶ Remove the cup holder before folding the seat.

### Folding the seat backrest forwards (table position)



- ▶ Fold up the armrests (→ page 77).
- ▶ Pull release handle ① for the seat backrest upwards and fold the seat backrest forwards.

## Folding the rear seat forwards

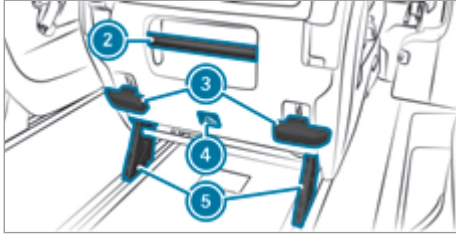

- ▶ **i** Pictogram **4** on the seat reminds you not to travel sitting behind a seat that has been folded forwards.
- ▶ Slide the folding table to its rearmost position (→ page 102).
- ▶ Remove the head restraint (→ page 96).
- ▶ Fold the seat backrest forwards into the table position.
- ▶ Pull one of release handles **3** upwards
- ▶ Grasp the seat by grab handle **2** and fold the seat forwards.
- ▶ **To fold back the rear seat:** using grab handle **2**, pull the seat backwards forcefully. The rear seat legs will engage.

The rear seat legs of the rear seat are correctly engaged when the seat legs engage audibly and indicator tabs **5** on the seat legs are no longer visible and have fully retracted into the seat legs.

## Installing and removing the rear seat

**⚠ WARNING** Risk of accident- and injury if the seat is not engaged

If a seat is not engaged, it may be thrown about while the vehicle is moving.

- ▶ Always make sure that all seats are engaged as described.

In order to ensure that the rear seats can securely engage, keep the seat guide rails and anchorages in the vehicle floor free of dirt and foreign objects.

If the indicator tab of the seat anchorage is not retracted into the seat leg, the seat is not correctly engaged. Engage the seat again.

**⚠ WARNING** Risk of injury- or fatal injury when the last row of seats is rotated 180 °

The vehicle occupants in the rear seats can be injured by unsecured loads.

This poses an increased risk of injury or even fatal injury.

- ▶ If loads are being transported, never install the rear seats in the last row of seats rotated by 180 °.
- ▶ Always store and secure objects and loads properly in the vehicle.

**⚠ WARNING** Risk of becoming trapped when adjusting the seats

When you adjust a seat, you may trap yourself or a vehicle occupant.

- ▶ When adjusting a seat, make sure that no one has any body parts in the sweep of the seat.

## Removing

When installing and removing the rear seats with seat heating and seat ventilation or the luxury rear seats, note the routing of the cables and their original installation positions. Otherwise, you may damage the cables and the on-board computer may detect the seat position incorrectly.

Use only rear seats with seat heating and seat ventilation or luxury rear seats that were supplied with the vehicle. Due to the high-quality design and the technical equipment, Mercedes-Benz recommends that you have luxury rear seats installed and removed at a qualified specialist workshop.

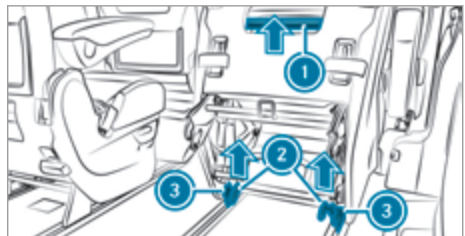

Rear seat folded forward (example: standard rear seat)

- ▶ Make sure that all sliders for fore-and-aft adjustment are engaged on both sides. It should not be possible to move the rear seat.

- ▶ Standard rear seat: fold the seat forwards (→ page 86).
  - ▶ Luxury rear seat: fold the seat forwards (→ page 88).
- i** For rear seats with seat heating and seat ventilation or luxury rear seats, the electrical connector must also be disconnected.

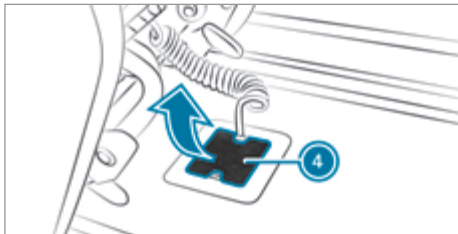

- ▶ Remove cover **4** of the floor socket.
- ▶ Remove the dummy cap from the bracket on the seat.

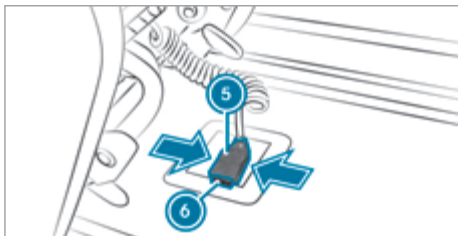

- ▶ Press in the sides of electrical connector **5** in socket **6** and remove.
- ▶ Insert the dummy cap into socket **6** and close the floor socket with cover **4**.
- ▶ Secure electrical connector **5** on bracket **7** and to the seat.
- ▶ Grasp the seat by grab handle **1** and fold two release handles **2** upwards.
- ▶ Move the folded seat towards the front and lift it out.

## Fitting

- ▶ Hold the seat by grab handle **1**.
  - ▶ From the front and above, guide the seat into front seat anchorages **3** in a tilted position and allow it to engage.
- i** For rear seats with seat heating and seat ventilation or luxury rear seats, the electrical connector must also be connected.
- ▶ Remove cover **4** of the floor socket and remove the dummy cap from socket **6**.
  - ▶ Remove electrical connector **5** for the seat ventilation and seat heating from bracket **7** and insert into socket **6**.
  - ▶ Attach the dummy cap to bracket **7** on the seat.
  - ▶ Close the floor socket with cover **4**.
  - ▶ Fold the seat back to the table or seat position (→ page 86) and slide into the basic setting (→ page 85).

## Using the EASY-ENTRY easy entry and exit feature (luxury rear seat)

**⚠ WARNING** Risk of accident- and injury if the seat is not engaged

If a seat is not engaged, it may be thrown about while the vehicle is moving.

- ▶ Always make sure that all seats are engaged as described.

In order to ensure that the seats can securely engage, keep the seat guide rails and anchorages in the vehicle floor free of dirt and foreign objects.

If the indicator tab of the seat anchorage is not retracted into the seat leg, the seat is not correctly engaged. Engage the seat again.

**⚠ WARNING** Risk of becoming trapped when adjusting the seats

When you adjust a seat, you may trap yourself or a vehicle occupant.

- ▶ When adjusting a seat, make sure that no one has any body parts in the sweep of the seat.

**⚠ WARNING** Risk of becoming trapped if the seat is not engaged

The seat does not engage when folded forwards. The seat can fold backwards unexpect-

edly, e.g. when accelerating, braking or in the event of an abrupt change of direction or an accident.

People in the seat's sweep can become trapped.

- ▶ If a seat is folded forwards, always fold it back before driving off.
- ▶ Make sure that the seat is engaged.

### Folding the luxury rear seat forwards

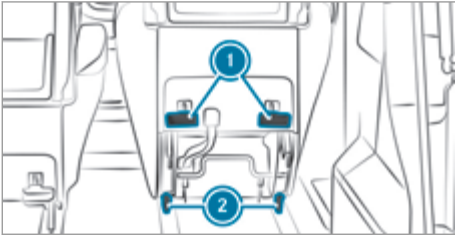

- ▶ Make sure that the luxury rear seat is in the upright position and the leg rest is fully folded under the sitting surface.
- ▶ Pull one of two EASY-ENTRY release handles
  - ① upwards and fold the luxury rear seat forward using the release handle.

or

- ▶ **For luxury rear seats installed on the left side only:** push the lever on the left side of the seat downwards and fold the luxury rear seat forwards.
- ▶ **To fold the luxury rear seat back:** fold the luxury rear seat back until it engages into the seat anchorages. Indicator tab ② will no longer be visible and will be fully retracted into the seat leg.

### Adjusting the luxury rear seat electrically

**⚠ WARNING** Risk of injury or death due to incorrect seat position

The seat belt will not offer the intended level of protection if you have not moved the seat backrest to an almost vertical position.

In particular, you may slip under the seatbelt and injure yourself.

- ▶ Adjust the seat properly before beginning your journey.
- ▶ Always ensure that the seat backrest is in an almost vertical position and that the shoulder section of your seat belt is

routed across the centre of your shoulder.

**⚠ WARNING** Risk of becoming trapped if the seat is adjusted by children

Children could become trapped if they adjust the seats, particularly if they are unattended.

- ▶ When leaving the vehicle, always take the key with you and lock the vehicle.
- ▶ Never leave children unattended in the vehicle.

**! NOTE** Damage to the leg rest due to overload

The leg rest can be damaged if it is loaded with more than 25 kg.

- ▶ Do not place more than 25 kg on the leg rest.

**! NOTE** Damage to the leg rest due to manual adjustment

The leg rest can be damaged if it is adjusted manually.

- ▶ Only adjust the leg rest electrically.

**! NOTE** Damage to the luxury rear seat due to incorrect position of the leg rest

If you turn the luxury rear seat's leg rest or set it in the longitudinal direction, the seat may be damaged.

- ▶ Only adjust the leg rest inclination as described in the following.

**Requirements:**

- The vehicle is switched on.

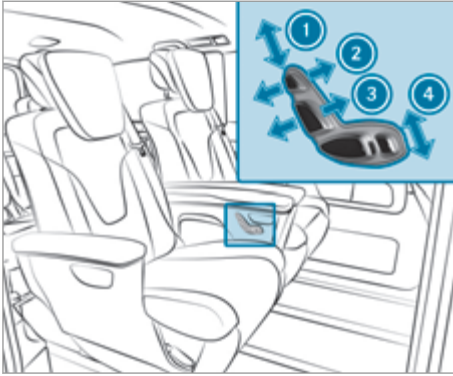

- ① Head restraint height adjustment
- ② Head restraint fore-and-aft adjustment
- ③ Seat backrest inclination adjustment
- ④ Leg rest inclination adjustment

▶ Adjust the luxury rear seat using the buttons on the left-hand side trim.

- ① You can save the settings for the luxury rear seats with the memory function (→ page 76).

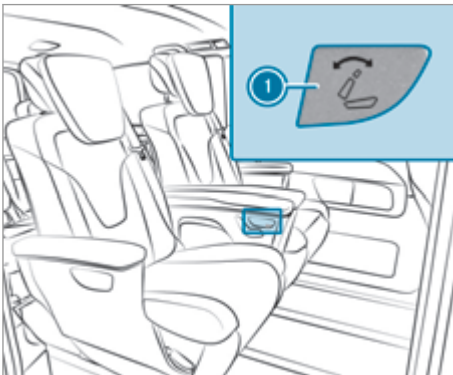
**Adjusting the upright position of the luxury rear seat**

▶ Press button ① until the luxury rear seat is in the upright position and the leg rest is fully folded under the seat surface.

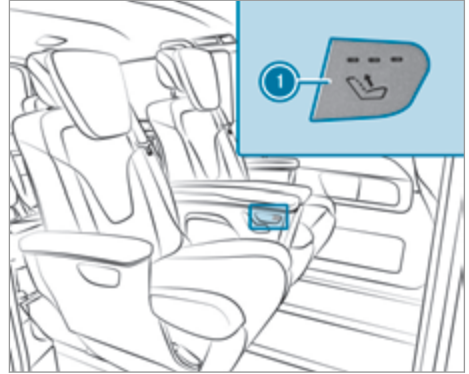
**Setting the massage function**

- ▶ **To switch on:** press button ① repeatedly until the desired massage program has been set.
- ▶ **To switch off:** press button ① until all indicator lamps are off.

**Moving the luxury rear seat**

**⚠ WARNING** Risk of becoming trapped when adjusting the seats

When you adjust a seat, you may trap yourself or a vehicle occupant.

- ▶ When adjusting a seat, make sure that no one has any body parts in the sweep of the seat.

**⚠ WARNING** Risk of injury due to moving the rear bench seat while the vehicle is in motion

If you move the rear bench seat while driving, the seat may move in an unexpected or jerking manner, for instance when braking.

You could become trapped as well as thrown against parts of the vehicle or other vehicle occupants.

- ▶ Only move the rear bench seat when the vehicle is stationary.
- ▶ Make sure that the rear bench seat is engaged after it is moved.

**⚠ WARNING** Risk of injury due to no protective effect from the window airbag

If you move the seat position outside the marked area, the window airbag can no longer provide optimum protection.

The protective effect of the window airbag is gradually reduced and may in some positions no longer be provided at all.

- ▶ Engage the rear seats or the rear bench seat on the guide rail within the marked area.

**⚠ WARNING** Risk of injury from the front seat being positioned too close to vehicle occupants

If you move the rear seats or the rear bench seat outside the markings on the guide rail, this could result in the passenger striking their head on the front seat.

- ▶ Maintain a minimum clearance of 5 cm between the knees of the respective vehicle occupants and the seat in front of them.

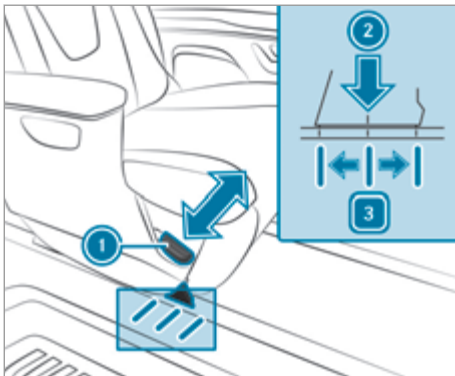

- ① Release handle for seat fore-and-aft adjustment
- ② Fore-and-aft setting marking
- ③ Basic setting marking

Starting from basic setting [3], you can move a luxury rear seat for vehicle occupants forwards or backwards by 5 cm. In doing so, make sure that vehicle occupants have sufficient legroom to reduce the risk of injury during braking.

- ▶ Pull release handle ① in the direction of the arrow.
- ▶ With the release handle pulled, slide the luxury rear seat to the desired position.
- ▶ Let go of release handle ①.

- ▶ Slide the luxury rear seat forwards and backwards until the sliders engage correctly on both sides.  
It should not be possible to move the seat.

### Moving the luxury rear seat from the second seat row

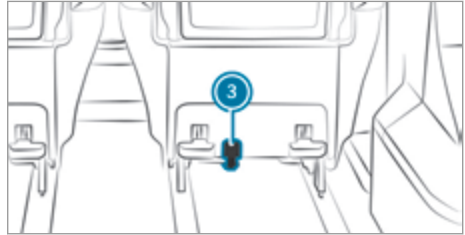

- ▶ Push lever ③ down.
- ▶ Slide the luxury rear seat forwards or backwards.

ⓘ A luxury rear seat is generally removed and installed in the same way as a standard rear seat (→ page 87). Due to the high-quality design and the technical equipment, Mercedes-Benz recommends that you have luxury rear seats installed at a qualified specialist workshop.

### Notes on the seat/bunk combination

**⚠ WARNING** Risk of becoming trapped when adjusting the rear bench seat

When adjusting a rear bench seat, you or another vehicle occupant could become trapped by the guide rail of the rear bench seat, for example.

- ▶ Make sure that no one has any part of their body within the sweep of the rear bench seat when adjusting it.

**⚠ WARNING** Risk of injury due to moving the rear bench seat while the vehicle is in motion

If you move the rear bench seat while driving, the seat may move in an unexpected or jerking manner, for instance when braking.

You could become trapped as well as thrown against parts of the vehicle or other vehicle occupants.

- ▶ Only move the rear bench seat when the vehicle is stationary.

- ▶ Make sure that the rear bench seat is engaged after it is moved.

**⚠ WARNING** Risk of injury due to no protective effect from the window airbag

If you move the seat position outside the marked area, the window airbag can no longer provide optimum protection.

The protective effect of the window airbag is gradually reduced and may in some positions no longer be provided at all.

- ▶ Engage the seat-/bunk combination on the guide rail within the marked area.

**⚠ WARNING** Risk of injury due to positioning the seat-/bunk combination outside the markings

If you move the seat-/bunk combination outside the markings on the guide rail, this could result in the passenger striking their head on the seat.

- ▶ Maintain a minimum clearance of 5 cm between the knees of the respective vehicle occupants and the seats in front of them.

**! NOTE** Damage to the seat belt retractor due to pulling on the seat belts

The function of the seat belt retractor can be impaired by pulling on the seat belts to adjust the seat backrest.

- ▶ Always use the grab strap on the seat backrest of the middle seat to align the seat backrest.

**! NOTE** Damage to the seat/bunk combination when moving

If you grasp and push the seat/bunk combination by the stowage compartment plastic cover only, the cover may break off.

If the space in front of or behind the seat/bunk combination is not clear, objects may become trapped when displaced.

The seat/bunk combination, trim or the objects may become damaged.

- ▶ To move, use the loop between the seat backrest and sitting surface.

- ▶ When moving, make sure that the space in front of or behind the seat/bunk combination is clear.

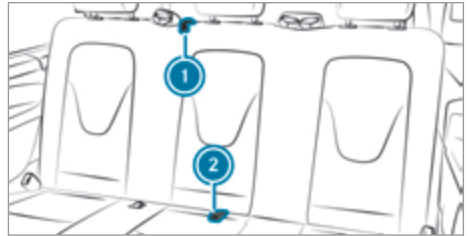

- ① Seat backrest grab strap
- ② Seat/bunk combination grab strap

Use only corresponding grab straps ① and ② to adjust the seat/bunk combination.

The seat/bunk combination can accommodate three persons. You can adjust the seat backrest to a vertical and horizontal position. If you set the seat backrest to the horizontal position, this – together with the bed extension – will give you a full-length bed for two people.

Passengers may use the seats of the seat/bunk combination only when the seat backrest is upright. Only then do the seat belts provide the intended degree of protection.

The seat/bunk combination is fitted with two removable stowage compartments under the seat surface (→ page 101). You can use these stowage compartments to store bedding, for example.

### Positioning the seats in the optimum area of protection

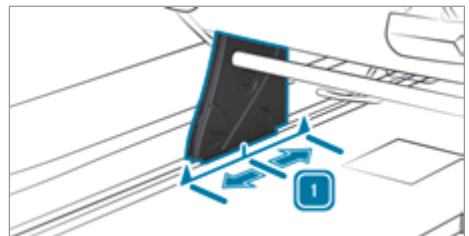

- ① Basic setting

Starting from the basic setting ①, the seat/bunk combination for passengers can be moved forwards or backwards by 5 cm. In doing so, make sure that passengers have sufficient legroom to reduce the risk of injury during braking.

## Using the seat/bunk combination

### Moving the seat/bunk combination

You can move the seat/bunk combination only when it is unoccupied. Pull the seat/bunk combination forwards using only the loop between the seat surface and the seat backrest.



- i** If the seat sliders on the front rear seat row are too far back in the guide rails, the seat/bunk combination cannot be moved forward. In this case, use the handle for the seat sliders to move the seat sliders.
- ▶ Pull release handle **1** up as far as it will go and hold it in this position.
- ▶ Grasp the loop between the seat surface and the seat backrest and move the seat/bunk combination.
- ▶ Let go of release handle **1**. The locking mechanism will engage automatically.
- ▶ Make sure that all seat sliders for fore-and-aft adjustment engage audibly on both sides. It should no longer be possible to move the seat/bunk combination.

### Bed extension

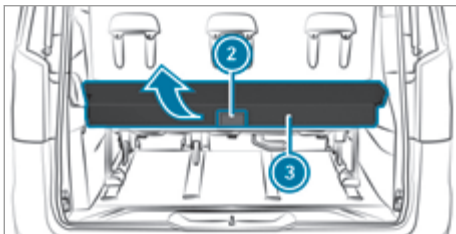

- ▶ **To fold up:** pull release handle **2** back and move bed extension **3** into an upright position. The bed extension will engage in an upright position.

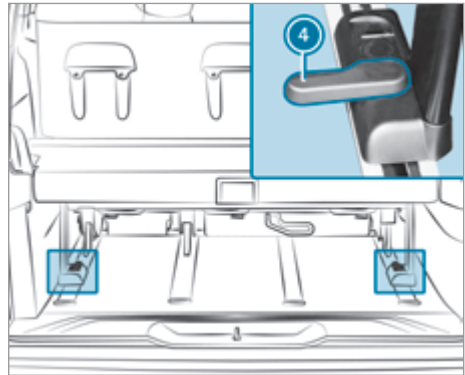

- ▶ **To remove:** fold up bed extension **3** and unscrew thumbscrews **4**. The bed extension will now be loose and capable of being removed from the guide rails.
- ▶ **To install:** guide bed extension **3** into the guide rails and tighten thumbscrews **4**.

### Setting up the berth

**⚠ WARNING** Risk of injury or death if the berth is used while the vehicle is in motion

Any vehicle occupant using a bed while the vehicle is in motion cannot be restrained properly.

- ▶ Use the bed only when the vehicle is parked.

**⚠ WARNING** Risk of becoming trapped when the seat backrest is folded up and down

When folding the seat backrest up or down, you could cause yourself or other vehicle occupants to become trapped.

- ▶ Make sure that the range of movement of the seat backrest is clear and that no one is trapped.

The safety net for the top berth is not a restraint system for vehicle occupants while the vehicle is in motion.

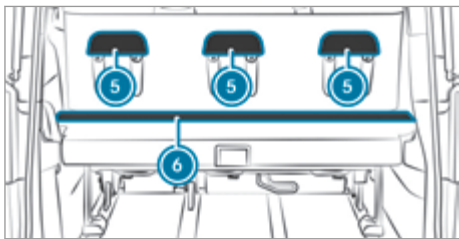

The berth can accommodate two persons.

- ▶ Fold up the short section of bed extension ⑥.

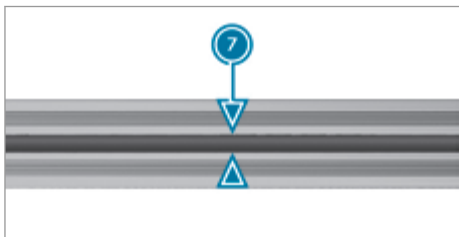

- ▶ Move the seat/bunk combination forwards to mark ⑦ on the guide rail.
- ▶ Remove the head restraints of the seat/bunk combination.
- ▶ Rotate the head restraints by 180° and insert them into brackets ⑤ on the rear side of the seat backrest.

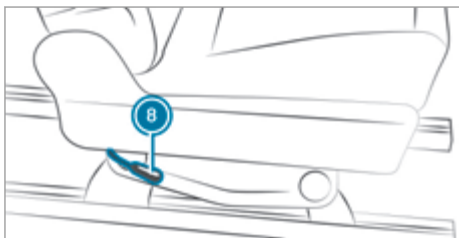

- ▶ Pull backrest release handle ⑧ up and adjust the seat backrest to a horizontal position. When doing so, hold on to the seat backrest only by the grab strap.
- ▶ Fold down the short section of the bed extension ⑥.

### Folding away the berth

- ▶ Perform the steps to set up the berth in reverse order.

After use, finish by moving the seat/bunk combination back to the basic setting and ensure that the seat backrest is in an upright position.

### Moving the seat sliders

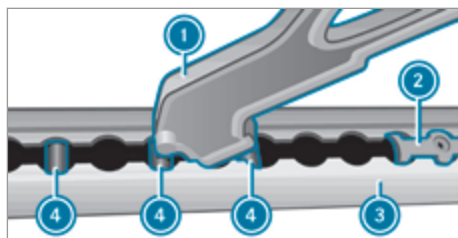
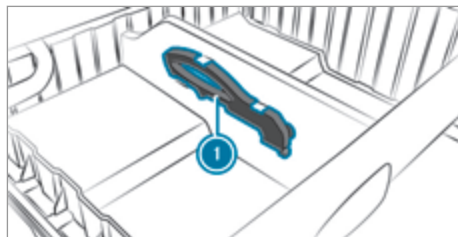

When you remove the seat/bunk combination, a rear bench seat or a seat, the seat slider may slide in a guide rail. The seat sliders will then no longer be parallel in the guide rails. In this case, you will no longer be able to fit the respective seating. The seat sliders must be moved using only the handle for seat sliders ① or at a qualified specialist workshop in order to prevent the risk of damage.

In addition, you can use the end of the handle to open and close the locks on the sliders.

- ① Handle ① is in the stowage compartment of the seat/bunk combination (→ page 101).
- ▶ Place the tip of handle ① onto the middle bolt of three bolts ④.
- ▶ Swing handle ① downwards onto seat slider ②.
- ▶ Press seat slider ② into guide rail ③ with handle ①. Seat slider ② will be unlocked.
- ▶ Move seat slider ② into the correct position and engage it.

## Installing and removing the seat/bunk combination

**⚠ WARNING** Risk of accident and injury as a result of rear bench seat not being engaged

If the rear bench seat is not engaged, it may be flung around during travel.

- ▶ Always make sure that the rear bench seat is engaged as described.

In order to ensure that the rear bench seat can securely engage, keep the seat guide rails and anchorages in the vehicle floor free of dirt and foreign objects.

If the indicator tab of the seat anchorage is not retracted into the seat leg, the seat is not correctly engaged. Engage the seat again.

### Removing the seat/bunk combination

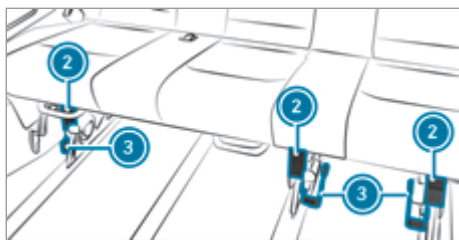
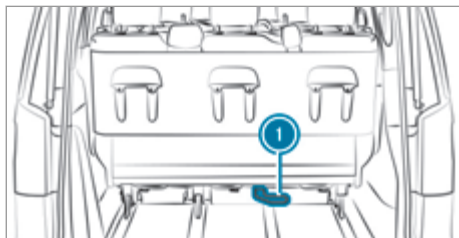

**i** In vehicles with a seat rail system, carry out the release, removal and subsequent reinstallation of a rear bench seat only at the marked basic setting.

- ▶ If necessary, remove the bed extension (→ page 93).
- ▶ Remove the stowage compartments (→ page 101).
- ▶ Fold the release handle for rear seat anchorage ① up.
- ▶ Tilt the seat/bunk combination forward using the upper edge of the seat backrest.

- ▶ Pull the release handle for front seat legs ② up.
- ▶ Hold the seat/bunk combination by the lower edge of the seat cushion.
- ▶ Fold the seat/bunk combination forwards and lift it out of seat anchorages ③.

### Installing the seat/bunk combination

A seat/bunk combination may not be fitted in the face-to-face position.

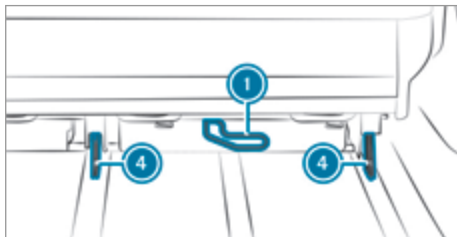

- ▶ Hold the seat/bunk combination by the lower edge of the seat cushion.
- ▶ Place the seat/bunk combination into front seat anchorages ③ from above at the front and engage it.
- ▶ Make sure that release handles for front seat legs ② are folded down in the direction of the floor of the vehicle.
- ▶ Fold the seat/bunk combination back into the seat position.
- ▶ Press the release handle for rear seat anchorage ① downwards until indicator tabs ④ have fully retracted into the rear seat legs.

The rear seat legs of the seat/bunk combination are correctly engaged when the seat legs engage audibly and indicator tabs ④ on the seat legs are no longer visible and have fully retracted into the seat legs.

## Head restraints

### Adjusting the head restraint manually

- ⚠ WARNING** Risk of accident due to adjusting the vehicle settings while the vehicle is in motion

You could lose control of the vehicle in the following situations in particular:

- if you adjust the driver's seat, the head restraint, the steering wheel or the mirror while the vehicle is in motion
- if you fasten your seat belt while the vehicle is in motion

- ▶ Before starting the vehicle: in particular, adjust the driver's seat, head restraint, steering wheel and mirror, and fasten your seat belt.

- ⚠ WARNING** Risk of injury due to head restraints not being fitted or being adjusted incorrectly

If head restraints have not been installed or have not been adjusted correctly, there is an increased risk of injury in the head and neck area, e.g. in the event of an accident or when braking.

- ▶ Always drive with the head restraints fitted.
- ▶ Before driving off, make sure for every vehicle occupant that the centre of the head restraint supports the back of the head at about eye level.

Do not interchange the head restraints of the front and rear seats. Otherwise, you will not be able to set the height and inclination of the head restraints to the correct position.

Using the head restraint fore-and-aft adjustment, adjust the head restraint so that it is as close to the back of your head as possible.

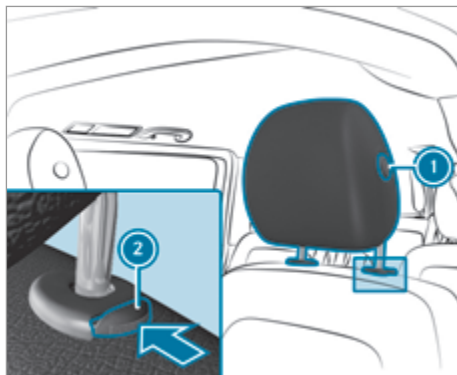

- ▶ **To raise:** pull the head restraint upwards into the desired position and ensure that it engages.

- ⓘ Use the head restraint only when it is engaged.

- ▶ **To lower:** press release button ②, slide the head restraint downwards into the desired position and ensure that it engages.

- ⓘ Use the head restraint only when it is engaged.

- ▶ **To move forwards or backwards:** press release button ① and pull the head restraint forwards or backwards until it engages in the desired position.

- ▶ **To remove:** press release button ② and pull the head restraint up and out.

- ▶ **To fit:** press the head restraint with detent into the holes on the left-hand side when viewed in the direction of travel until it engages.

### Adjusting the head restraint electrically

- ⚠ WARNING** Risk of accident due to adjusting the vehicle settings while the vehicle is in motion

You could lose control of the vehicle in the following situations in particular:

- if you adjust the driver's seat, the head restraint, the steering wheel or the mirror while the vehicle is in motion
- if you fasten your seat belt while the vehicle is in motion

- ▶ Before starting the vehicle: in particular, adjust the driver's seat, head restraint,

steering wheel and mirror, and fasten your seat belt.

**⚠ WARNING** Risk of injury due to head restraints not being fitted or being adjusted incorrectly

If head restraints have not been installed or have not been adjusted correctly, there is an increased risk of injury in the head and neck area, e.g. in the event of an accident or when braking.

- ▶ Always drive with the head restraints fitted.
- ▶ Before driving off, make sure for every vehicle occupant that the centre of the head restraint supports the back of the head at about eye level.

Do not interchange the head restraints of the front and rear seats. Otherwise, you will not be able to set the height and inclination of the head restraints to the correct position.

Adjust the mechanical head restraint fore-and-aft position so that it is as close as possible to the back of your head.

**!** **NOTE** Damage to the electrical head restraint when adjusted manually

If the height of the electrically adjustable head restraint is adjusted manually, this can damage the mechanism of the head restraint.

- ▶ Adjust the height of the electrically adjustable head restraints using the buttons in the door trim.

#### Requirements:

- The vehicle is switched on or the door is open.

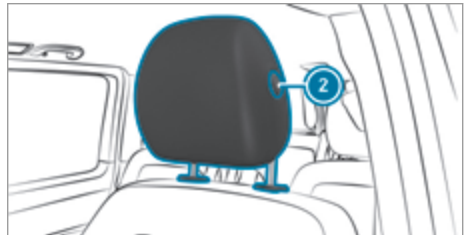
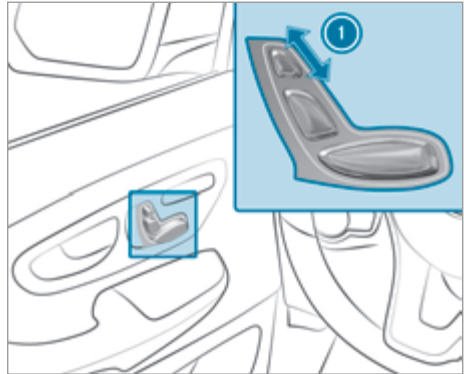

- ▶ **To adjust the height:** push button ① up or down in the direction of the arrow.

#### Moving forward or back

- ▶ Press and hold release knob ②.
  - ▶ Push the head restraint forwards or backwards until it engages in the desired position.
- ① If the vehicle is not switched on, you can adjust the head restraint height within 30 seconds of unlocking the vehicle.

#### Adjusting the head restraint on a luxury rear seat

#### Adjusting the side bolsters

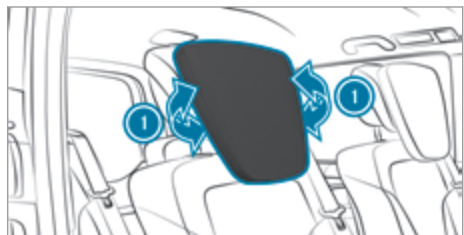

- ▶ Push or pull right-hand and left-hand side bolster ① into the desired position.

### Adjusting the head restraint electrically

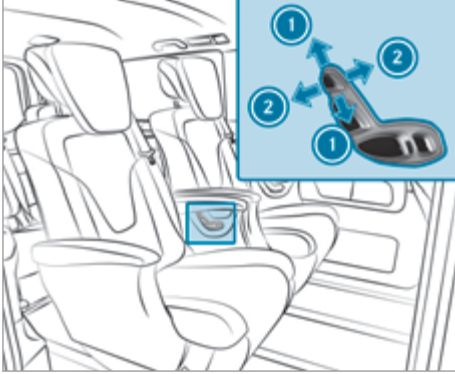

- ▶ Switch on the vehicle.
- ▶ **To adjust the height:** slide the button up or down in the direction of arrow ①.
- ▶ **To adjust the longitudinal direction:** slide the button forwards or backwards in the direction of arrow ②.

### Switching the seat heating on/off

- ⚠ WARNING** Risk of burns due to repeatedly switching on the seat heating

Repeatedly switching on the seat heating can cause the seat cushion and seat backrest padding to become very hot.

In particular, the health of persons with limited temperature sensitivity or a limited ability to react to high temperatures may be affected or they may even suffer burn-like injuries.

- ▶ Do not repeatedly switch on the seat heating.

To protect against overheating, the seat heating may be temporarily deactivated after it is switched on repeatedly.

- ! NOTE** Damage to the seat heating due to overheating

The seat heating may overheat if the seat is unoccupied when the seat heating is switched on or if objects are placed on the seat.

- ▶ Switch off the seat heating when the seat is unoccupied.
- ▶ Do not place any objects on the seat when the seat is unoccupied.

### Requirements:

- The power supply has been switched on.

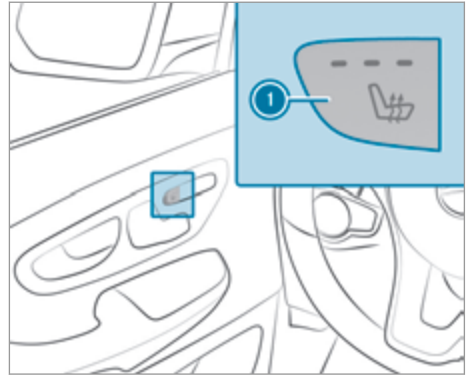

Front seat

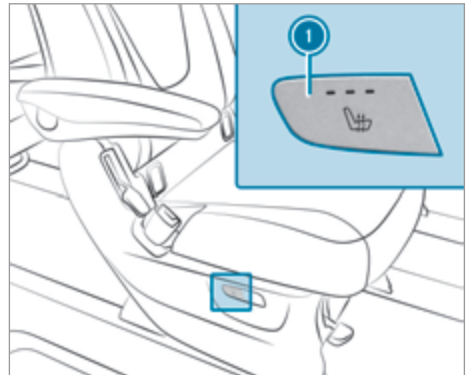

Comfort rear seat

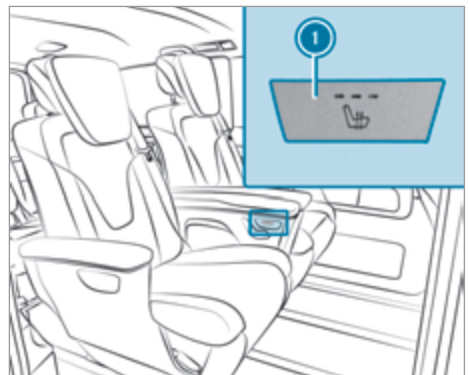

Luxury rear seat

- ▶ **To switch on / increase the level:** press button ① repeatedly until the desired heating level is set.  
Depending on the heating level, one to three indicator lamps will light up.
  - ▶ **To switch off / reduce the level:** press button ① repeatedly until the desired heating level is set.  
When all indicator lamps are off, the seat heating is switched off.
- ① The seat heating will automatically switch back out of the three heating levels after 7, 10 and 20 minutes until the seat heating switches off.
  - ① Rear seat heating activation is possible only once the vehicle has been switched on.

### Switching the seat ventilation on and off

#### Requirements:

- The power supply has been switched on.

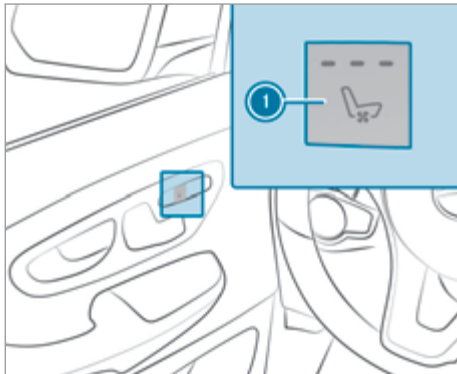

Front seat

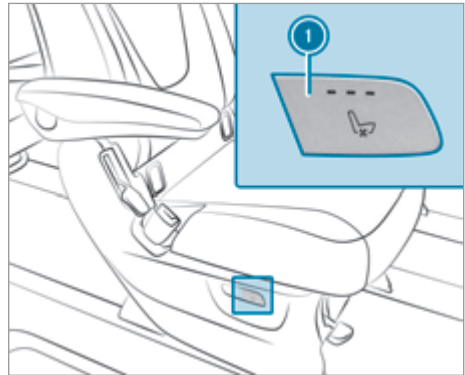

Comfort rear seat

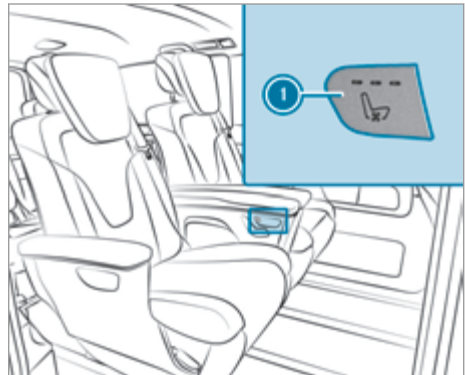

Luxury rear seat

- ▶ Make sure that the air inlet grilles on the back of the seat backrest are not covered.
  - ▶ **To switch on / increase the level:** press button ① repeatedly until the desired blower setting is set.  
Depending on the blower setting, one to three indicator lamps will light up.
  - ▶ **To switch off / reduce the level:** press button ① repeatedly until the desired blower setting is set.  
If all indicator lamps are off, the seat ventilation is switched off.
- ① The convenience opening function automatically switches the seat ventilation for the driver's seat to the highest blower setting (→ page 130).
  - ① Rear seat ventilation activation is possible only once the vehicle has been switched on.

## Steering wheel

### Adjusting the steering wheel

- ⚠ WARNING** Risk of accident due to adjusting the vehicle settings while the vehicle is in motion

You could lose control of the vehicle in the following situations in particular:

- if you adjust the driver's seat, the head restraint, the steering wheel or the mirror while the vehicle is in motion
- if you fasten your seat belt while the vehicle is in motion

▶ Before starting the vehicle: in particular, adjust the driver's seat, head restraint, steering wheel and mirror, and fasten your seat belt.

- ⚠ WARNING** Risk of accident due to unlocked steering wheel

The steering wheel may move unexpectedly if it is unlocked while the vehicle is in motion.

- ▶ Make sure that the steering wheel is locked before driving off.
- ▶ Never unlock the steering wheel when the vehicle is in motion.

- ⚠ WARNING** Risk of entrapment for children when adjusting the steering wheel

Children could injure themselves if they adjust the steering wheel.

- ▶ Never leave children unattended in the vehicle.
- ▶ When leaving the vehicle, always take the key with you and lock the vehicle.

### Adjusting the steering wheel

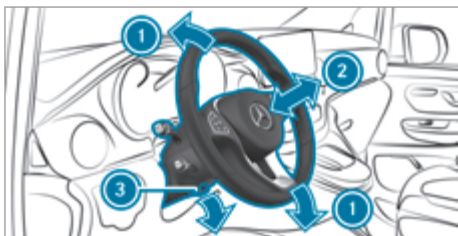

- ▶ **To unlock:** push release lever ③ down as far as it will go.  
The steering column is unlocked.
- ▶ Adjust height ① and distance ② to the steering wheel.
- ▶ **To lock:** push release lever ⑤ up as far as it will go.  
The steering column is locked.

## Stowage areas

### Stowage spaces and stowage compartments

#### Opening and closing the stowage compartment in the centre console

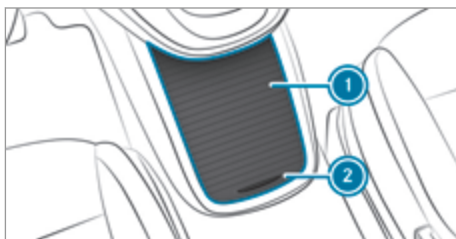

- ▶ Slide cover ① of the centre console up or down using handle ②.

The following can be found in the stowage compartment of the centre console depending on the vehicle's equipment:

- A 12 V socket (→ page 106) or the cigarette lighter (→ page 106)
- The Media Interface with two USB ports or with two USB ports and one SD card slot
- The holder for the mobile phone cradle
- The ashtray (→ page 105)
- A stowage compartment or a device installation frame for auxiliary equipment, e.g. a tachograph

#### Opening and closing the stowage compartment under the armrest

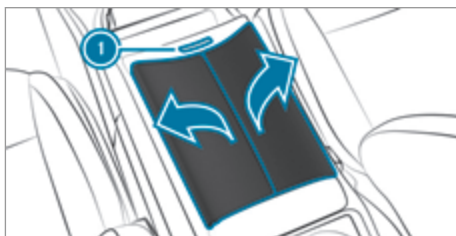

- ▶ **To open:** press button ①.  
The stowage compartment will open.
- ▶ **To close:** press to close the flaps of the stowage compartment in any order.

### Opening and closing the glove compartment

**⚠ WARNING** Risk of injury due to objects being stowed incorrectly

If objects in the vehicle interior are stowed incorrectly, they can slide or be thrown around and hit vehicle occupants. In addition, cup holders, open stowage spaces and mobile phone brackets cannot always retain all objects they contain.

There is a risk of injury, particularly in the event of sudden braking or a sudden change in direction.

- ▶ Always stow objects in such a way that they cannot be thrown around in such situations.
- ▶ Always make sure that objects do not protrude from stowage spaces, luggage nets or stowage nets.
- ▶ Close the lockable stowage spaces before starting a journey.
- ▶ Always stow and secure heavy, hard, pointed, sharp-edged, fragile or bulky objects in the boot.

Observe the notes on loading the vehicle.

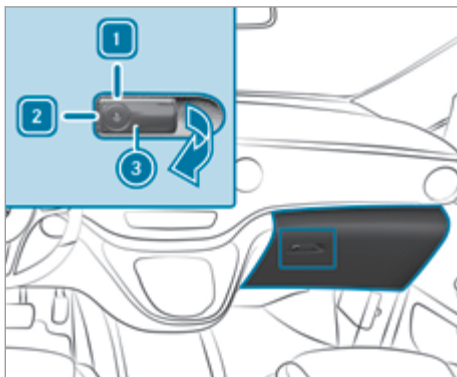

- ① Unlocked
- ② Locked
- ③ Glove compartment handle

- ▶ **To lock/unlock:** turn the emergency key a quarter turn anti-clockwise ② (to lock) or clockwise ① (to unlock).
- ▶ **To open:** pull glove compartment handle ③ in the direction of the arrow.
- ▶ **To close:** fold the glove compartment handle up and press on it until it engages.

### Opening the glasses compartment



- ▶ Press on glasses compartment ①.

### Installing and removing stowage compartments underneath the seat/bunk combination

#### Removing

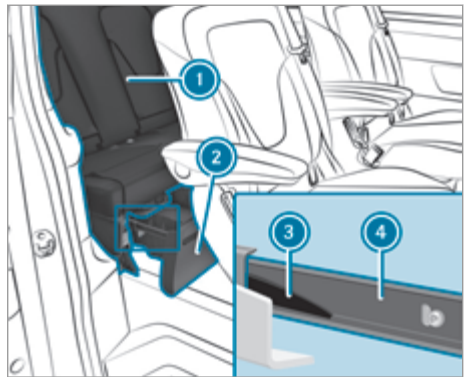

- ① The maximum load that can be placed in each stowage compartment is 13 kg.
- ▶ Slide seat/bunk combination ① as far back as possible (→ page 93).
- ▶ Pull stowage compartment ② out as far as it will go.
- ▶ Pull left-hand plastic tongue ③ down and right-hand plastic tongue ④ up, when viewed in the direction of travel. Pull out stowage compartment ② a little each time. The corresponding stop will be released.
- ▶ Pull out stowage compartment ②.

## Fitting

- ▶ Slide seat/bunk combination ① as far back as possible (→ page 93).
- ▶ Slide stowage compartment ② into guide rails ④ underneath the seat/bunk combination. Plastic tongues ③ will engage automatically.

## Folding table

### Installing and removing the folding table

**⚠ WARNING** Risk of injury from unsecured items in the vehicle

If objects, luggage or loads are not secured or not secured sufficiently, they could slip, tip over or be thrown around and thereby hit vehicle occupants.

There is a risk of injury, particularly in the event of sudden braking or a sudden change in direction.

- ▶ Always stow objects in such a way that they cannot be thrown around.
- ▶ Before the journey, secure objects, luggage or loads against slipping or tipping over.

**⚠ WARNING** Risk of accident- and injury due to the folding table not being engaged

The folding table can come loose and be flung around while the vehicle is in motion.

- ▶ Install the folding table as described.
- ▶ Only move the folding table when the vehicle is stationary.
- ▶ Ensure that the folding table is correctly engaged.

**! NOTE** Damage to the folding table or the armrest when the rear seats are folded forwards or backwards

If the folding table is not positioned all the way back when the rear seats are folded forwards or backwards, the folding table and/or the armrest of the rear seat may be damaged.

- ▶ Slide the folding table all the way back before folding the rear seats forwards or backwards.

## Installing the folding table

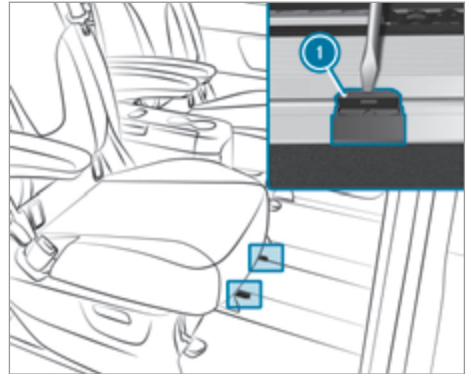

- ▶ Observe the notes on loading (→ page 217).
- ▶ Push the rear seats back fully or, if necessary, remove them.
- ▶ Lift both covers ① out of the guide rail slightly using a suitable tool, e.g. a screwdriver.

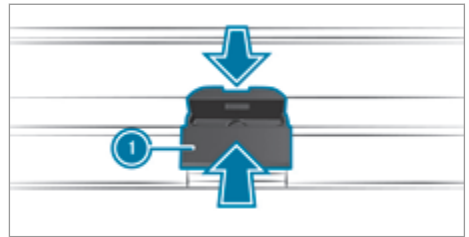

- ▶ Press both covers ① together slightly and remove them from the guide rail. The openings in the rail for the middle slide on the underside of the folding table will be open.
- ▶ Rotate the folding table until the arrow on the underside of the folding table is pointing in the direction of travel.

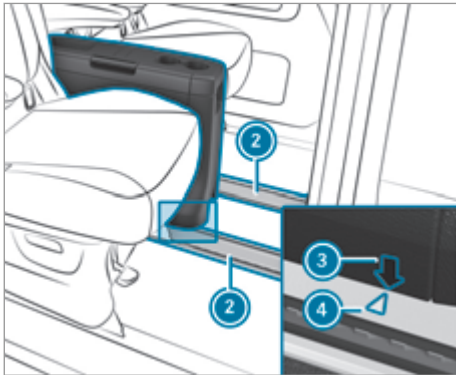

#### Installation position

- ▶ Insert the folding table into guide rail ② so that arrows ③ on the folding table point to both markings ④ on guide rail ②. The guides and slide on the underside of the folding table fit into the guide rail.

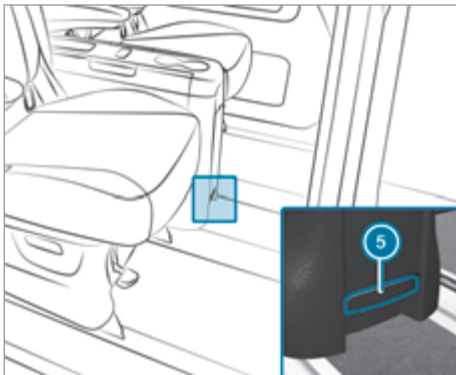

- ▶ Pull lever ⑤ on the front or rear side of the folding table upwards and push the folding table backwards.

Press both covers ① together slightly and engage them in the openings of the guide rails.

#### Moving the folding table

- ▶ Pull and hold lever ⑤ and move the folding table into the desired position.
- ▶ Release lever ⑤.
- ▶ Move the folding table until it automatically engages in the next possible position.
- ▶ After repositioning the table, ensure that the folding table is properly secured again.

#### Removing the folding table

- ▶ Fold in the table panels and retract the table.
- ▶ Push the rear seats back fully or, if necessary, remove them.
- ▶ Push the folding table back so that covers ① of the openings in the rail can be removed.
- ▶ Lift both covers ① out of the guide rail slightly using a suitable tool, e.g. a screwdriver.
- ▶ Press both covers ① together slightly and remove them from guide rail ②. The openings in the rail for the middle slide on the underside of the folding table will be open.
- ▶ Push the folding table forwards into the installation position. Arrows ③ on the folding table point to both markings ④ on guide rail ②.
- ▶ Lift the folding table out of guide rail ②.
- ▶ Press both covers ① together slightly and engage them in the openings of guide rails ②.

#### Using the folding table

##### Extending the folding table

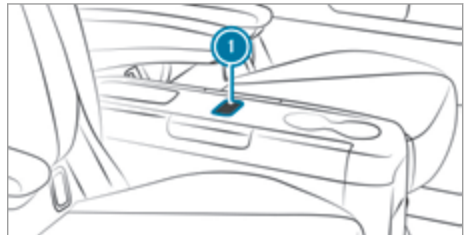

- ▶ Press button ① all the way down and release it. The folding table will move upwards and engage automatically.

##### Retracting the folding table

- ▶ Press button ① all the way down and simultaneously press the centre section of the folding table downwards.
- ▶ Release button ① when the folding table is in its retracted position. The centre section of the folding table will engage automatically.

### Folding the table panel in and out

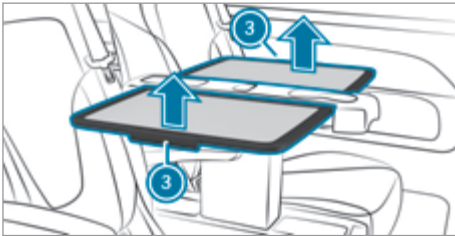
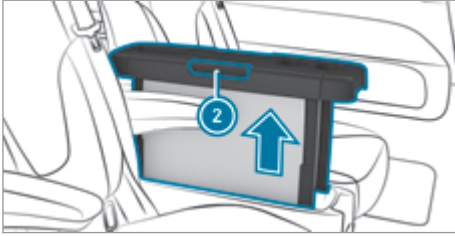

- ▶ **To fold out the table panel:** pull out the table panels upwards to the stop using handle ② and swing them to the side until they engage.
- ▶ **To fold in the table panel:** swing the table panels up using handle ③ and slide them vertically downwards into the table.

### Installing and removing the insert

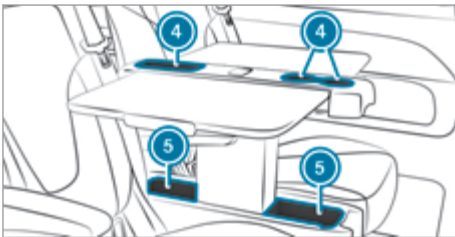

- ④ Recesses on the folding table
- ⑤ Stowage compartments

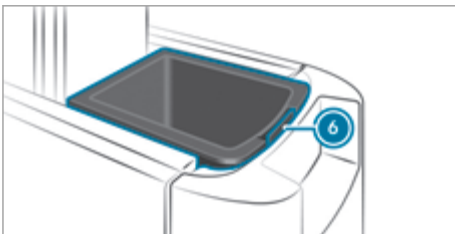

- ▶ **To remove:** press lug ⑥ and remove the insert.
- ▶ **To install:** put in the insert and press it down until it engages.

### Folding the folding table in and out on the seat backrest

**⚠ WARNING** Risk of injury from an open folding table

Vehicle occupants may bump into the folding table and injure themselves.

- ▶ Close the folding table before each journey.

### Folding the folding table out

Do not subject the folding table to a load greater than 2 kg.

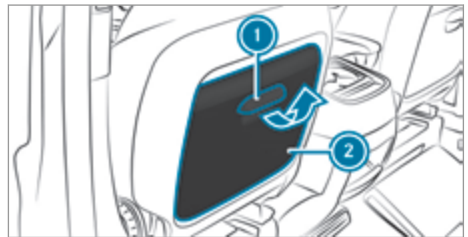

- ▶ Pull handle ① on folding table ② upwards. Folding table ② has been unlocked.

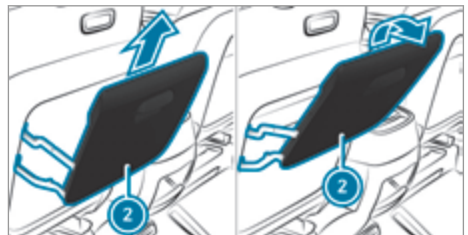

- ▶ Pull folding table ② up with handle ① and swing it out.

## Folding the folding table in

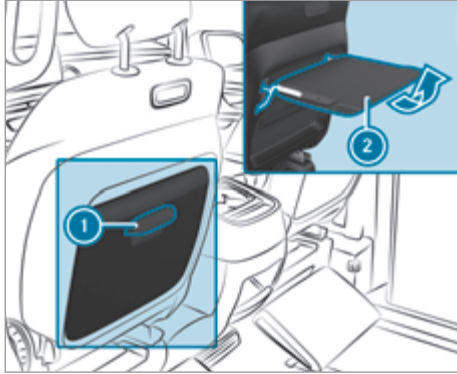

- ▶ Pull folding table ② up with handle ① and swing it in until it engages.

## Information about the bottle holder

The bottle holders are in front of the stowage compartments in the front doors.

There are additional bottle holders on the left and right in the rear compartment side trim.

## Cup holders

### Inserting the cup holder in the rear passenger compartment

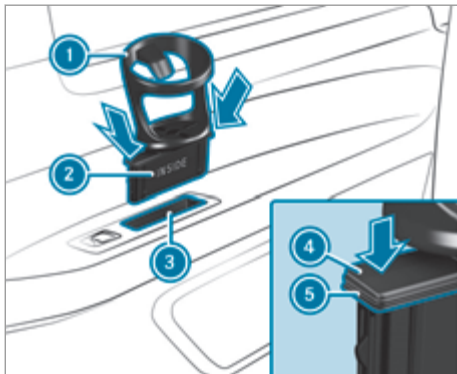

- ▶ Position cup holder ① above stowage compartment ③ so that the lettering "INSIDE" on its base ② faces towards the vehicle interior.
- ▶ Insert base ② into stowage compartment ③ and press down on both sides.

The cup holder is correctly inserted when both sealing rings ⑤ are inserted in stowage compartment ③ and upper edge ④ of the base locks positively with stowage compartment ③.

- ▶ **To remove:** grasp the bottom of cup holder ① from below and remove it by lifting its base ② out vertically.

## Switching the temperature-controlled cup holder on and off

### Requirements:

- The vehicle is switched on.

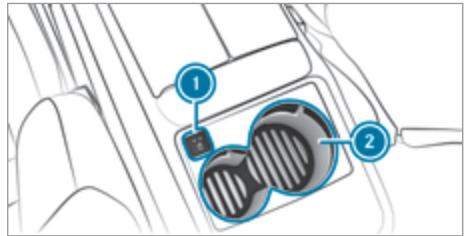

- ▶ **To switch on:** press button ① repeatedly until the blue (keep cool) or red (keep warm) indicator lamp in the button lights up.
- ▶ **To switch off:** press button ① repeatedly until the indicator lamp in the button goes out.

- ① Clean the removable rubber mat only with clean, lukewarm water and cup holder ② only with a damp cloth.

## Ashtray and cigarette lighter

### Using ashtrays

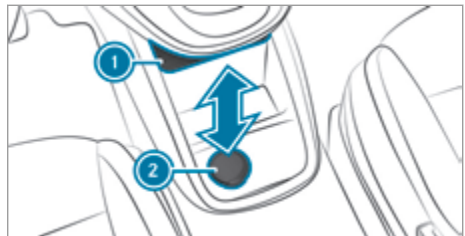

- ▶ Slide cover ① of the centre console upwards (→ page 100).
- ▶ Insert the ashtray with cap ② into a cup holder in the centre console with cover or into a cup holder in the rear passenger compartment.

## Using the ashtray and cigarette lighter in the rear passenger compartment

### Requirements:

- The vehicle is switched on.

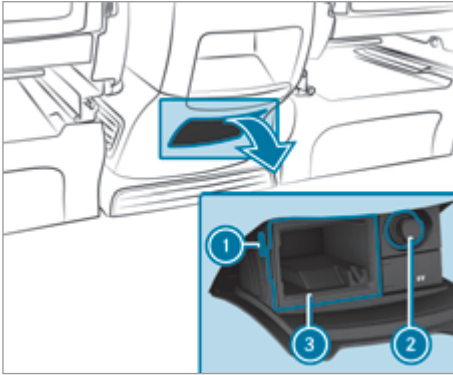

- ▶ Pull down the cover.
- ▶ **To use the cigarette lighter:** press cigarette lighter ②. The cigarette lighter will pop out when the heating element is red-hot.
- ▶ **To remove the ashtray:** press ribbing ① and remove insert ③.
- ▶ **To insert the ashtray:** push in insert ③ from above and press it into the holder until it engages.

## Using the cigarette lighter in the front centre console

**⚠ WARNING** - Risk of fire and injury from the hot cigarette lighter

You can burn yourself if you touch the hot heating element or the socket of the cigarette lighter.

In addition, flammable materials may ignite if:

- you drop the hot cigarette lighter
- a child holds the hot cigarette lighter to objects, for example

- ▶ Always hold the cigarette lighter by the knob.
- ▶ Always make sure that the cigarette lighter is out of reach of children.
- ▶ Never leave children unattended in the vehicle.

### Requirements:

- The power supply has been switched on.

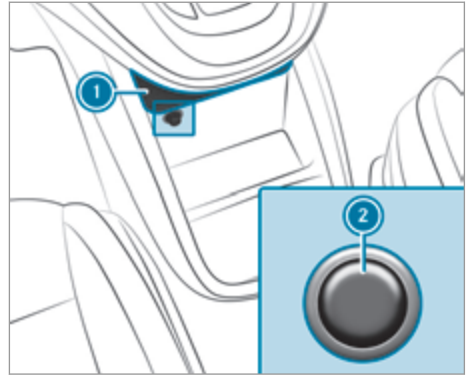

Cigarette lighter in the centre console (example: centre console with cover)

- ▶ Slide cover ① of the centre console upwards (→ page 100).
- ▶ Press in cigarette lighter ②.
- ⓘ You can use the cigarette lighter socket for accessories with a maximum current draw of 180 W (15 A).

## Sockets

### Using the 12 V socket in the front centre console

### Requirements:

- The power supply has been switched on.
- Only devices with up to a maximum of 180 watts (15 A) are permissible.



- ▶ Slide cover ① of the centre console upwards (→ page 100).
- ▶ Fold up cover ② of the socket.
- ▶ Insert the plug of the device.

## Using the socket in the rear centre console

### Requirements

- The power supply has been switched on.
- Only devices with up to a maximum of 180 W (15 A) are permissible.

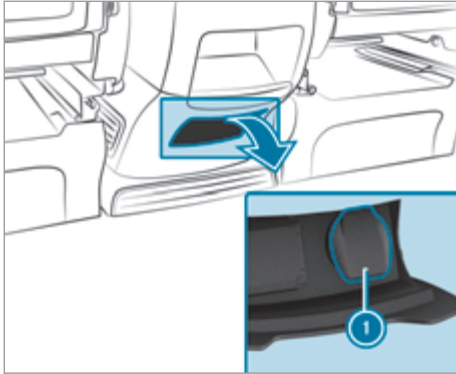

- ▶ Pull down the cover.
- ▶ Fold out the cover of socket ①.
- ▶ Insert the plug of the device.

## Using the 230 V socket

**⚠ DANGER** Risk of fatal injuries due to damage from a connecting cable or socket

You could receive an electric shock when pulling the connecting cable or the 230 V power socket out of the trim, or if it is damaged or wet.

- ▶ Use only connecting cables that are dry and free of damage.
- ▶ When the vehicle is switched off, make sure that the 230 V power socket is dry.
- ▶ Immediately have the 230 V power socket checked or replaced at a qualified specialist workshop if it is damaged or has been pulled out of the trim.
- ▶ Never plug the connecting cable into a 230 V power socket that is damaged or has been pulled out of the trim.

**⚠ DANGER** Risk of death due to using the socket incorrectly

In particular, you could receive an electric shock:

- if you touch the inside of the socket
  - if you insert unsuitable devices or objects into the socket
- ▶ Do not touch the inside of the socket.
  - ▶ Only connect suitable devices to the socket.

**⚠ DANGER** Risk of fatal injuries due to electric shock

If you clean the 230 V socket with a wet cloth, you can receive an electric shock.

There is a risk of fatal injury!

- ▶ Avoid the area around the 230 V socket when cleaning.

### Requirements:

- Only connect devices with a suitable plug which conforms to the standards specific to the country you are in.
- A device up to a maximum of 150 W (0.65 A) is used.
- Do not use multiple socket outlets.
- The on-board electrical system voltage is within a permissible voltage range.
- The electronic device plug is inserted fully into the 230 V socket.

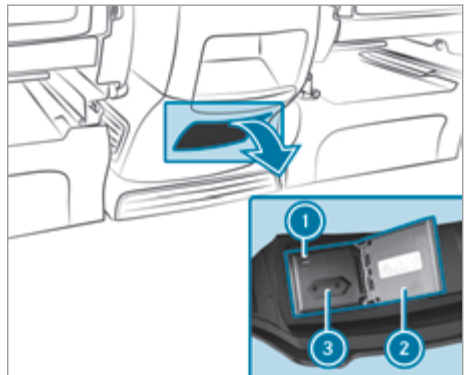

- ▶ Open flap ②.

- ▶ Insert the plug of the device into 230 V socket ③.
- ▶ When the on-board electrical system voltage is sufficient, indicator lamp ① lights up.

If you will not be using the 230 V power socket, keep the flap closed.

### Switching the refrigerator box in the centre console on and off

**⚠ WARNING** Risk of fire due to a covered ventilation grille on the coolbox

If you cover the ventilation grille for the coolbox, it may overheat.

- ▶ Always make sure that the ventilation grille is not covered.

The coolbox ventilation grille is between the front seat base and the centre console sidewall.

#### Requirements:

- The vehicle is switched on.
- The stowage compartment under the armrest is open (→ page 100).

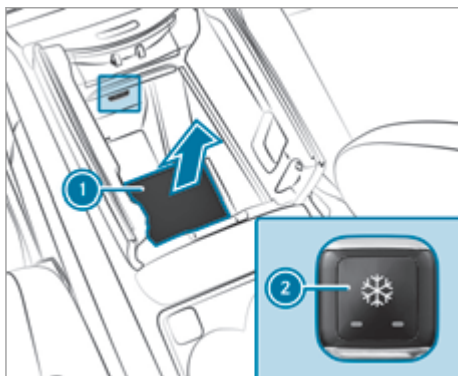

The refrigerator box can bear a maximum load of 3.5 kg.

- ▶ **To open:** fold cover ① upwards.
- ▶ **To switch the cooling level to low:** press button ② for approximately two seconds.
- ▶ **To switch the cooling level to high:** press button ② again.
- ▶ **To switch off:** press button ② for approximately two seconds until all indicator lamps go out.

- ① If you do not need to use the refrigerator box for an extended period, you should switch it off, defrost it and clean it. After doing so, leave the lid open for a time.

### Notes on attaching the iPad®

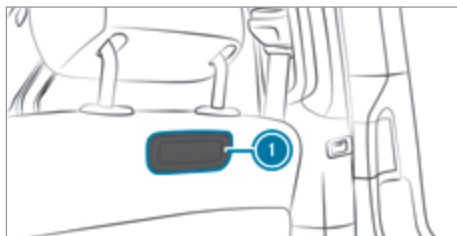

Your vehicle is equipped with iPad® attachment ① on the driver's and co-driver's seat backrests.

A mount, which has been tested and approved especially for Mercedes-Benz vehicles, is available as an accessory. Only this mount can unlock the attachment opening and allow the iPad® to be charged whilst it is installed.

iPad® attachment ① may only be used for accessories up to 42 W (3.5 A).

Contact a Mercedes-Benz Service Centre for information and availability. Before using the mount, please read the operating instructions for the mount.

- ① Only use accessories which have been tested and recommended by Mercedes-Benz.

## Exterior lighting

### Notes on changing the lights when driving abroad

#### Low beam

In countries in which traffic drives on the opposite side of the road from the country in which the vehicle is registered, you will have to switch the headlamps to symmetrical dipped beam. This will prevent oncoming traffic from being dazzled. Symmetrical dipped beam will no longer illuminate the edge of the carriageway as far or as high.

#### Vehicles with halogen headlamps:

It is not necessary to change the headlamps over to symmetrical dipped beam. The statutory requirements of the countries in which traffic drives on the opposite side of the road from the country in which the vehicle is registered will also be met without changing over.

#### Vehicles with LED headlamps:

You can set the low beam for driving on the right or left via the on-board computer (→ page 192).

### Information about lighting systems and your responsibility

The vehicle's various lighting systems are only aids. The vehicle driver is responsible for adjusting the vehicle's lighting to the prevailing light, visibility, statutory conditions and traffic conditions.

### Light switch

#### Operating the light switch

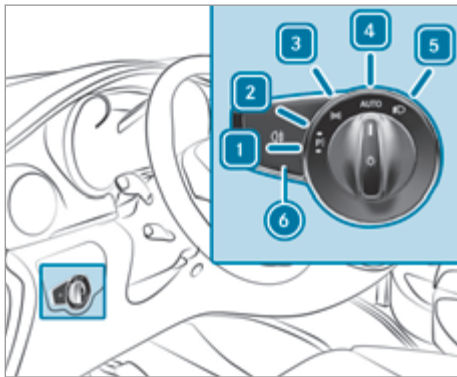

- 1 Left parking lights  
2 Right parking lights

- 3 Standing lights and licence plate and instrument lighting  
4 Automatic driving lights (preferred light switch position)  
5 Low beam or high beam  
6 Rear fog light

If you hear a warning tone when exiting the vehicle, the lights may still be on.

- ▶ Turn the light switch to .

The exterior lighting (except standing and parking lights) will automatically switch off in the following cases:

- If you remove the key from the ignition lock.
- if you open the driver's door while the key is in position in the ignition lock.

#### Switching on the daytime running lights

- ▶ Turn the light switch to .

#### Automatic driving lights function

The standing lights, low beam and daytime running lights will be switched on automatically depending on the vehicle status and the light conditions.

**⚠ WARNING** Risk of accident when the dipped beam is switched off in poor visibility

When the light switch is set to , the dipped beam may not be switched on automatically if there is fog, snow or other causes of poor visibility such as spray.

- ▶ In such cases, turn the light switch to .

The automatic driving lights are only an aid. Responsibility for vehicle lighting rests with you.

If the standing lights and low beam have been switched on, the green (standing lights) and (low beam) indicator lamps on the instrument cluster will light up.

#### Activating/deactivating the fog lights

##### Requirements:

- The light switch is in the or position.
- The power supply or the vehicle has been switched on.

- ▶ **To switch the rear fog light on or off:** press the button.

Comply with the country-specific regulations for using the rear fog lamp.

### Adjusting headlamp range

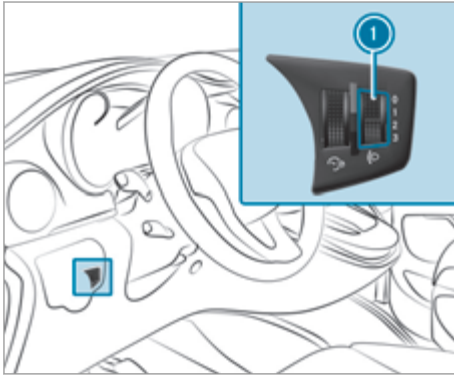

- ▶ Turn headlamp range adjuster ① to the required position.
- ▶ If the vehicle is unladen, select position 0.

The illumination of the road should be 40 m to 100 m and the low beam must not dazzle oncoming traffic.

You can use the headlamp range adjuster to adjust the light cone of the headlamps to your vehicle's load condition. As the seats are occupied or the load compartment is loaded or unloaded, the light cone changes. This may cause visibility conditions to deteriorate and you could dazzle oncoming traffic.

### Operating the combination light switch

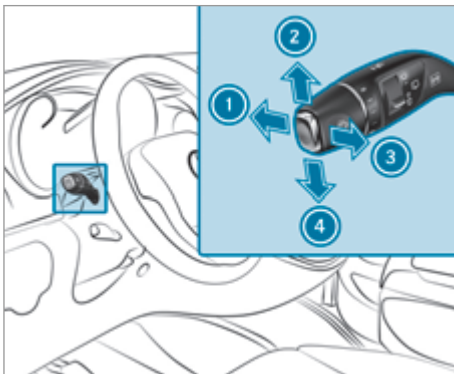



- ① High beam
- ② Right turn signal light

- ③ Headlamp flashing
- ④ Left turn signal light

- ▶ Use the combination switch to select the desired function.

### Switching on high beam

- ▶ Switch on the low beam (→ page 109).
- ▶ Push the combination switch forwards ①. The  indicator lamp on the instrument cluster will light up.
- ① In the **AUTO** position, the high beam switches on only in darkness and when the vehicle is switched on.
- ▶ **To switch off:** move the combination switch back to its starting position. The  indicator lamp goes out on the instrument cluster.

### Headlamp flashing

- ▶ Briefly pull the combination switch in the direction of arrow ③.

### Turn signal light

- ▶ **To indicate:** push the combination switch in the required direction ② or ④ until it engages. In the case of larger steering movements, the combination switch will reset itself automatically.
- ▶ **To indicate briefly:** tap the combination switch briefly in the required direction ② or ④. The corresponding turn signal lamp will flash three times.

### Switching the hazard warning light system on/off

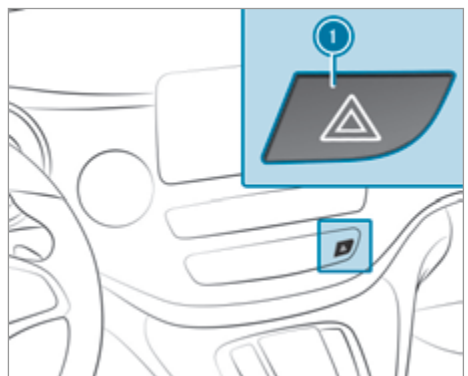

- ▶ Press button ①.

If you operate a turn signal indicator while the hazard warning light system is switched on, only the turn signal lamps on the relevant side of the vehicle will light up.

The hazard warning light system will switch on automatically in the following situations:

- The airbag is deployed
- The vehicle is heavily braked from a speed of more than 70 km/h to a standstill.

The hazard warning light system will automatically switch off when the vehicle regains a speed of more than 10 km/h after maximum full-stop braking.

## Intelligent Light System

### Function of the Intelligent Light System

The Intelligent Light System adapts the headlamps' lighting function to the current driving and weather situation.

The system comprises the following functions:

- Active light function (→ page 111)
- Cornering light (→ page 111)
- Motorway mode (→ page 111)
- Enhanced fog light function (→ page 112)

You can switch the Intelligent Light System function on or off via the on-board computer (→ page 112).

### Active light function



The active light function has the following functions:

- The headlamps follow the steering movements.
- Relevant areas are better illuminated during a journey.

The functions will be active when low beam is switched on.

The active light function can, for example, detect pedestrians, cyclists and animals at an earlier stage.

### Cornering light function



The function is active under the following conditions:

- Your speed is less than 40 km/h and the turn signal light has been switched on or the steering wheel is turned.
- Your speed is between 40 km/h and 70 km/h and the steering wheel is turned.

The cornering light may still light up for a short time but will be switched off automatically after a maximum of three minutes.

### Motorway mode function

Motorway mode increases the range and brightness of the cone of light, enabling better visibility.



Motorway mode will automatically be activated in the following cases:

- Your speed is greater than 110 km/h and the vehicle has covered at least 1,000 m without any significant steering movement.
- Your speed is greater than 130 km/h.

If your speed falls below 80 km/h after motorway mode has been activated, it will automatically be deactivated.

### Enhanced fog light function

The enhanced fog light function reduces self-dazzling and improves the illumination of the edge of the carriageway.













If your speed is below 70 km/h and the rear fog light has been switched on, the enhanced fog light function will automatically be activated.

The enhanced fog light function will automatically be deactivated after activation in the following cases:

- Your speed is greater than 100 km/h.
- The rear fog light will be switched off.

### Switching the Intelligent Light System on/off

- ▶ Press the  button to call up the list of menus.
  - ▶ Use the  or  button to select **Settings**.
  - ▶ Press the  button.
  - ▶ Use the  or  button to select **Lights**.
  - ▶ Press the  button.
  - ▶ Use the  or  button to select **Intelligent Light System**.
- If the Intelligent Light System has been switched on, the display will show the  symbol in yellow on the instrument cluster.
- ▶ Press the  button.

When you switch on the Intelligent Light System function, you will enable the following functions:

- Motorway mode
- Active light function
- Cornering light
- Enhanced fog light function

- ① If you set the low beam for driving on the right or left, the display will show the display message **Inactive for left-side traffic** or **Inactive for right-side traffic** in the **Lights** submenu instead of **Intelligent Light System** (→ page 192). This display message will

appear only if the setting for driving on the right or left is the opposite to your vehicle's national version.

- ① You can find further information in "Intelligent Light System" (→ page 111).

### Adaptive Highbeam Assist

#### Adaptive Highbeam Assist function

**⚠ WARNING** Risk of accident despite Adaptive Highbeam Assist

Adaptive Highbeam Assist does not react to:

- road users without lights, e.g. pedestrians
- road users with poor lighting, e.g. cyclists
- road users whose lighting is obstructed, e.g. by a barrier

On very rare occasions, Adaptive Highbeam Assist may fail to recognise other road users with their own lighting, or may recognise them too late.

In these, or in similar situations, the automatic high beam will not be deactivated or will be activated despite the presence of other road users.

- ▶ Always observe the road and traffic conditions carefully and switch off the high beam in good time.

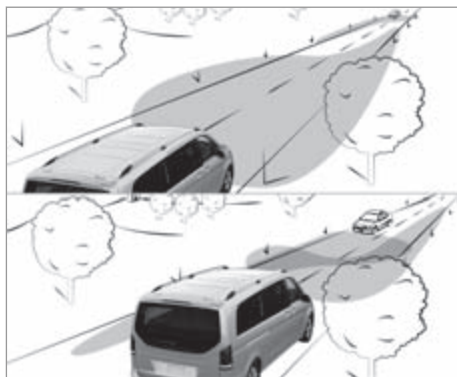

The Adaptive Highbeam Assist automatically switches between the following settings:

- Low beam
- High beam

The system detects that vehicle lights are approaching in the opposite direction or driving ahead of the vehicle.

If your speed is greater than 30 km/h and no other road users are detected, high beam will automatically be switched on.

If your speed is greater than 25 km/h, the headlamp range will be controlled automatically depending on the distance from other road users. High beam will automatically be deactivated in the following cases:

- Your speed is lower than 25 km/h.
- Other road users have been detected.
- The road is sufficiently illuminated.

### System limits

Adaptive Highbeam Assist cannot take the road, weather or traffic conditions into consideration.

The detection of obstacles may be restricted if:

- visibility is poor, e.g. in fog, heavy rain or snow.
- the sensors are dirty or covered.

Adaptive Highbeam Assist is only an aid. You are responsible for ensuring correct vehicle lighting in accordance with the prevailing light, visibility and traffic conditions.

The system's optical sensor is located behind the windscreen near the overhead control panel.

### Switching Highbeam Assist on/off

#### Requirements:

- The light switch is in the **AUTO** position.

▶ **To switch on:** switch on high beam using the combination switch. When the high beam is switched on automatically in the dark, the  indicator lamp will light up on the instrument cluster display.

▶ **To switch off:** switch off high beam using the combination switch.

## Adaptive Highbeam Assist Plus

### Adaptive Highbeam Assist Plus function

**⚠ WARNING** Risk of accident despite Adaptive Highbeam Assist Plus

Adaptive Highbeam Assist Plus does not react to:

- road users without lights, e.g. pedestrians
- road users with poor lighting, e.g. cyclists
- road users whose lighting is obstructed, e.g. by a barrier

On very rare occasions, Adaptive Highbeam Assist Plus may fail to recognise other road users with their own lighting, or may recognise them too late.

In these, or in similar situations, the automatic high beam will not be deactivated or will be activated despite the presence of other road users.

▶ Always observe the road and traffic conditions carefully and switch off the high beam in good time.

Adaptive Highbeam Assist Plus cannot take into account road, weather or traffic conditions.

Detection may be restricted in the following cases:

- In poor visibility, e.g. fog, heavy rain or snow
- if there is dirt on the sensors or the sensors are obscured

Adaptive Highbeam Assist Plus is only an aid. You are responsible for ensuring correct vehicle lighting in accordance with the prevailing light, visibility and traffic conditions.





Adaptive Highbeam Assist Plus switches automatically between the following light types:

- Low beam
- Partial high beam
- High beam

Partial high beam uses high beam to shine past other road users rather than dazzling them. The low beam illumination area covers the vehicle in front.

At speeds lower than 25 km/h or if there is insufficient street lighting, Highbeam Assist Plus will perform the following actions:

- Partial high beam and high beam will be automatically deactivated.
- The  indicator lamp on the instrument cluster will go out. The  symbol for Highbeam Assist Plus will remain switched on.

At speeds greater than 30 km/h, Highbeam Assist Plus will perform the following actions:

- If no other road users are detected, high beam will be switched on.
- If other road users are detected, partial high beam will be switched on.
- The  indicator lamp on the instrument cluster will light up.

At speeds greater than 40 km/h, Highbeam Assist Plus will perform the following actions:

- If no other road users are detected and the road is straight, high beam will be switched on.
- If highly reflective signs are detected, high beam will automatically be switched off.
- If other road users are detected, partial high beam will be switched on automatically.
- The  indicator lamp on the instrument cluster will light up.

The system's optical sensor is located behind the windscreen near the overhead control panel.

### Switching Adaptive Highbeam Assist Plus on/off

#### Requirements:

- The light switch is in the **AUTO** position.

▶ **To switch on:** switch on high beam using the combination switch.

When the high beam is switched on automatically in the dark, the  indicator lamp will light up on the instrument cluster display.

▶ **To switch off:** switch off high beam using the combination switch.

### Setting the exterior lighting switch-off delay time

#### Requirements:

- The light switch is in the **AUTO** position.

Multimedia system:

▶  ▶ Settings ▶ Lights  
▶ Ext. light. del. sw. off

▶ Set a switch-off delay time.

When the vehicle is switched off, the exterior lighting will be activated for the set time.

### Activating and deactivating the surround lighting

Multimedia system:

▶  ▶ Settings ▶ Lights  
▶ Surround lighting

▶ Activate or deactivate the function.

The exterior lighting will remain on for 40 seconds after the vehicle is unlocked. When you start the vehicle, the surround lighting will be deactivated and the automatic driving lights activated.



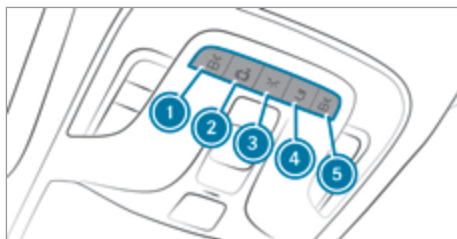

### Adjusting the interior lighting

#### Adjusting the interior lighting

##### Front overhead control panel



Interior lighting buttons (example: comfort overhead control panel)

- ①  Front-left reading lamp
- ②  Automatic interior lighting control
- ③  Front interior lighting
- ④  Rear or load compartment lighting
- ⑤  Front-right reading lamp

▶ **To switch on/off:** press the corresponding button ① - ⑤.

The layout and number of buttons depend on the equipment.

### Operating unit in the grab handle

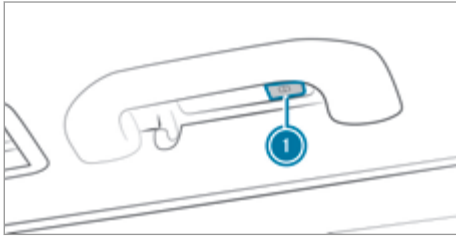

①  Rear reading lamp

▶ **To switch on/off:** press button ①.

### Adjusting ambient lighting

Multimedia system:

▶  ▶ **Comfort** ▶ **Ambient lighting**

#### Setting the colour

▶ Select **Colour**.

▶ Set the required colour.

or

▶ Select a colour combination.

#### Adjusting the brightness

▶ Select **Brightness**.

▶ Adjust the brightness.

### Switching the interior lighting switch-off delay time on/off

Multimedia system:

▶  ▶ **Settings** ▶ **Lights**

▶ **Int. light. del. sw. off**

▶ Switch the switch-off delay time on or off. If the function is active, the interior lighting will switch on automatically when the vehicle is unlocked or switched off.

### Changing bulbs

#### Instructions for replacing light sources

**⚠ WARNING** Risk of burns from hot component parts whilst replacing a bulb

Bulbs, lamps and plug connectors can become very hot during operation.

When replacing a bulb, you could burn yourself on these component parts.

▶ Allow the component parts to cool down before replacing the bulbs.

#### Important safety notes

- Before changing the bulbs, switch off the vehicle's lighting system. This will prevent a short circuit.
- Use only spare bulbs of the same type and with the correct voltage.
- Use bulbs only in enclosed lamps that have been designed for them.
- Do not use any light source that has been dropped or has scratches on its glass tube. Otherwise, the light source may explode.
- The light source may explode under the following conditions:
  - if it is hot and you touch it
  - if you drop it
  - if you scratch it
- Stains on the glass tube will reduce the service life of the light source. Do not touch the glass tube with your bare hands. If necessary, clean the glass tube with alcohol or spirits while it is cold and wipe it down with a lint-free cloth.
- Protect light bulbs from humidity and do not bring them into contact with liquids.

Always ensure the bulbs are firmly secured.

Have the following light sources changed at a qualified specialist workshop only:

- Additional turn signal lamps on the outside mirror
- Bulbs in the licence plate lighting

## Replacing front light bulbs (vehicles with halogen headlamps)

### Overview of front light source types



- ➊ Additional turn signal lamp on the outside mirror: LED
- ➋ Turn signal light: PY 21 W
- ➌ Low beam: H7 55 W
- ➍ High beam/standing/parking lights/daytime running lights: H15 55 W/15 W

### Replacing light sources in the headlamp

#### Requirements:

- The lighting system is switched off.
- The appropriate front wheel is turned inwards.
- **Low beam:** you require a H7 55 W light bulb.
- **Turn signal light:** you require a PY 21 W light bulb.
- **High beam / standing/parking lights / daytime running lights:** you require a H15 55 W/15 W light bulb.

### Fitting/removing the cover in the front wheel arch

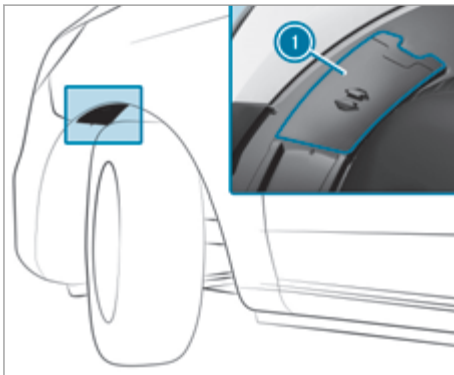

- ▶ **To remove:** grip the centre of cover ➊, slide it upwards and pull it out. The cover will hang downwards on the strap.

- ▶ **To fit:** insert cover ➊ at the top and slide it downwards until it engages.

### Low beam

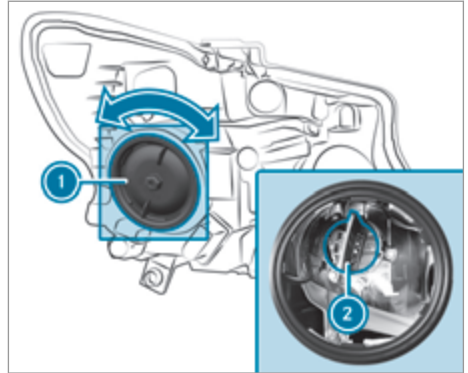

- ▶ Remove the cover in the front wheel arch.
- ▶ Turn housing cover ➊ anti-clockwise and remove it.
- ▶ Turn socket ➋ for low beam to the left and pull it out.
- ▶ Pull the bulb out of socket ➋.
- ▶ Insert the new bulb into socket ➋.
- ▶ Insert socket ➋ and rotate it to the right to tighten it.
- ▶ Press on housing cover ➊ and rotate it to the right to tighten it.
- ▶ Replace the cover in the front wheel arch.

### High beam, standing/parking lights and daytime running lights

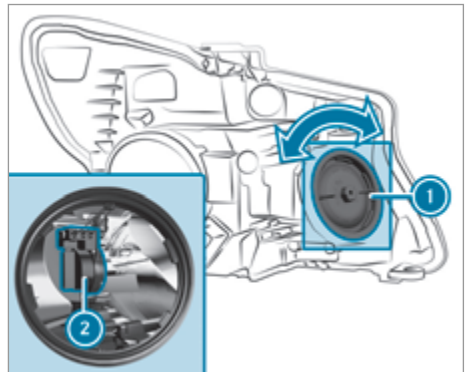

- ▶ Open the bonnet.

- ▶ Turn housing cover ❶ anti-clockwise and remove it.
- ▶ Pull out the bulb with socket ❷.
- ▶ Insert the new bulb with socket ❷ and engage it as far as it will go.
- ▶ Press on housing cover ❶ and rotate it to the right to tighten it.
- ▶ Close the bonnet.

### Turn signal light

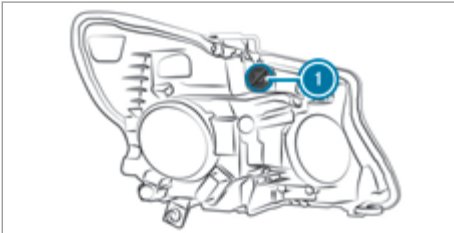

- ▶ Open the bonnet.
- ▶ Turn socket ❶ anti-clockwise and pull it out.
- ▶ Pull the bulb out of socket ❶.
- ▶ Insert the new bulb into socket ❶.
- ▶ Insert socket ❶ and turn it clockwise until it engages.
- ▶ Close the bonnet.

### Replacing rear bulbs

#### Overview of rear light source types



Vehicles with standard tail lamp

- ❶ Third brake light: LED
- ❷ Licence plate lighting: LED
- ❸ Rear fog light (driver's side): P 21 W
- ❹ Reversing light: P 21 W
- ❺ Brake light, tail light/parking lights: P 21 W
- ❻ Turn signal light: P 21 W

Vehicles with LED tail lamps

- ❶ Third brake light: LED
- ❷ Licence plate lighting: LED
- ❸ Rear fog light (driver's side): LED
- ❹ Reversing light: W 16 W
- ❺ Brake light, tail light/parking lights: LED
- ❻ Turn signal light: LED

### Replacing light sources in the tail lamp

#### Requirements

- The lighting system is switched off.
- **Standard tail lamp:** you require a P 21 W light source.
- **LED tail lamp:** you require a W 16 W light source.

#### Removing the tail lamp

**!** **NOTE** Damage to the paintwork during tail lamp removal

The paintwork may be damaged when the tail lamps are removed. The tail lamp may, for example, scratch the paintwork when it is removed.

- ▶ Remove the tail lamps carefully.
- ▶ Mercedes-Benz recommends having the tail lamp light sources replaced at a qualified specialist workshop.

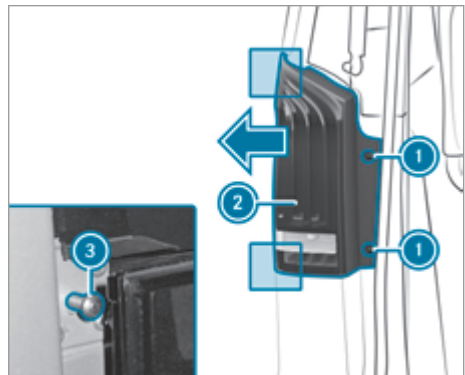

Please note that you can change the bulb of the reversing light only in the case of an LED tail lamp.

- ▶ Open the tailgate.
- ❶ You will find a screwdriver in the vehicle tool kit (→ page 253).
- ▶ Unscrew two side screws ❶.

- ▶ Push tail lamp ② outwards against bolts ③ as far as it will go.
- ▶ Press tail lamp ② off outwards and away from bolts ③.
- ▶ Pull the connector off the bulb mount of tail lamp ②.

### Installing the tail lamp

- ▶ Push the connector into the bulb mount of tail lamp ②.
- ▶ Push tail lamp ② onto bolts ③ from the side and press it against the vehicle.
- ▶ Tighten two side screws ①.

### Standard tail lamp

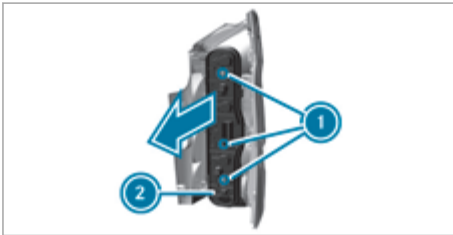

- ▶ Unscrew three screws ① and remove bulb mount ② from the tail lamp.

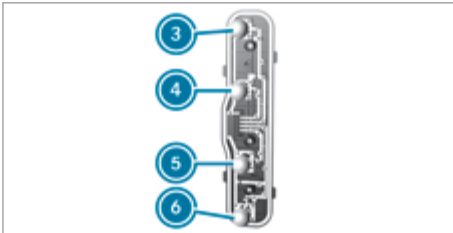

### Bulb mount

- ③ Turn signal light
- ④ Brake light, tail light, parking light
- ⑤ Reversing light
- ⑥ Rear fog light (only on the driver's side)

- ▶ Remove the tail lamp.
- ▶ Gently turn the bulb anti-clockwise and take it out of the socket.
- ▶ Push the new bulb into the socket and turn it clockwise to screw it in.
- ▶ Insert bulb mount ② into the tail lamp and tighten all three screws ①.
- ▶ Install the tail lamp.

### LED tail lamp



- ▶ Remove the tail lamp.
- ▶ Unscrew housing cover ① by turning it anti-clockwise.
- ▶ Turn the socket anti-clockwise and pull it out.
- ▶ Pull the bulb out of the socket.
- ▶ Insert the new bulb into the socket.
- ▶ Insert the socket and rotate it clockwise to tighten it.
- ▶ Press on housing cover ① and rotate it clockwise to tighten it.
- ▶ Install the tail lamp.

### Replacing interior light bulbs

#### Replacing illuminants in the interior

#### Requirements:

- The interior lighting has been switched off.
- **Rear and load compartment lamp:** you require a T10 6W xenon illuminant.
- **Interior and surround lighting:** you require a W 5 W illuminant.
- **Signal and ambient lamp in the tailgate:** you require a W 5 W illuminant.

### Rear and load compartment lamps

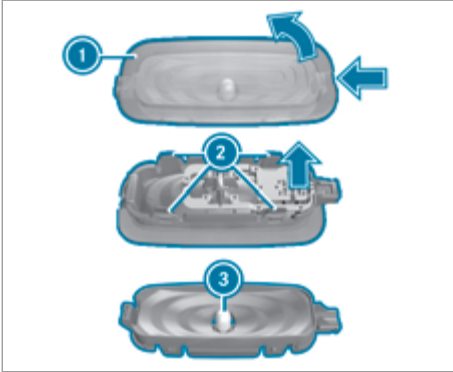

- ▶ Push in the catch spring of lens ① with a suitable object, e.g. a screwdriver, and then prise off the lens with the lamp housing.
- ▶ Push the lugs of socket ② inwards.
- ▶ Remove light source ③ from the lamp housing.
- ▶ Insert the new illuminant.
- ▶ Position the lens on the lamp housing and engage it.
- ▶ Align the lens with the lamp housing and engage it.

### Additional interior and surround lighting

Depending on the equipment, replacing the illuminants as described here applies to the following lamps:

- The sun visor mirror lamp
- The ambient lamp at the bottom of the front door
- The ambient lamp on the inside of the tailgate

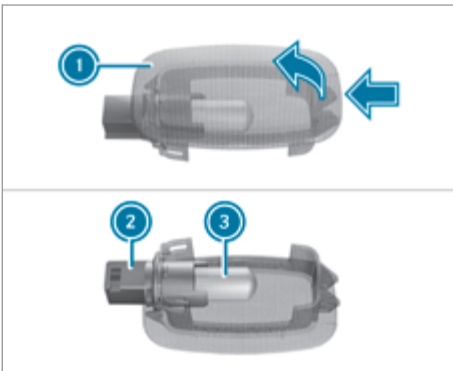

- ▶ Push in the catch spring of lamp housing ① with a suitable object, e.g. a screwdriver, and prise off lamp housing ①.
- ▶ Turn socket ② anti-clockwise and pull it out of lamp housing ①.
- ▶ Pull bulb ③ out of socket ②.
- ▶ Push new bulb ③ into socket ②.
- ▶ Screw socket ② into lamp housing ① by turning it clockwise.
- ▶ Place lamp housing ① in position on the left and engage it.

### Signal and ambient lamp in the tailgate

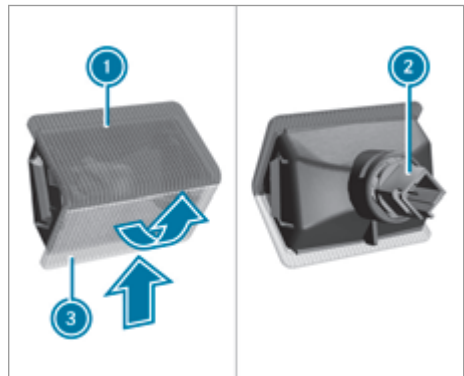

- ▶ Push in the catch spring of the lamp housing on the side of transparent lens ③ with a suitable object, e.g. a screwdriver, and prise off the lamp housing.
- ▶ Turn socket ② anti-clockwise and pull it out of the lamp housing.
- ▶ Pull the bulb out of socket ②.
- ▶ Push the new bulb into socket ②.
- ▶ Screw socket ② into the lamp housing by turning it clockwise.
- ▶ Place the lamp housing in position at the side of red lens ① and engage it.

## Windscreen wipers

### Switching the windscreen wipers on and off

#### Requirements:

- The power supply has been switched on.



- 1 0 Windscreen wipers off
- 2 ... Intermittent wiping, low (low rain sensor sensitivity)
- 3 .... Intermittent wiping, high (high rain sensor sensitivity)
- 4 — Continuous wiping, slow
- 5 == Continuous wiping, fast

- ▶ Turn the combination switch to the corresponding position 1 – 5.
- ▶ **Single wiping:** push the button on the combination switch in the direction of arrow 6.
- ▶ **Washing:** push the button on the combination switch in the direction of arrow 6 as far as the second point of resistance.

### Switching the rear window wiper on/off

#### Requirements:

- The power supply has been switched on.

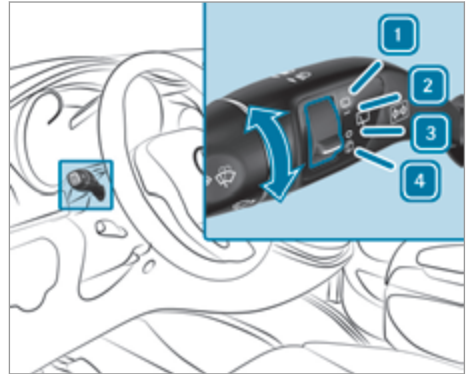

- 1 Wiping with washer fluid
- 2 Intermittent wiping
- 3 0 Rear window wiper off
- 4 Wiping with washer fluid

- ▶ Move the switch to the corresponding position. When the rear window wiper is switched on, the symbol will appear on the instrument cluster display.
- ▶ **Wiping with washer fluid:** press and hold the switch beyond the current position up to the 1 or 4 limit.

### Replacing the windscreen wiper blades

**⚠ WARNING** Risk of becoming trapped if the windscreen wipers are switched on while wiper blades are being replaced

If the windscreen wipers begin to move while you are changing the wiper blades, you can be trapped by the wiper arm.

- ▶ Always switch off the windscreen wipers and vehicle before changing the wiper blades.

**! NOTE** Damage to the windscreen or rear window during wiper blade replacement

If the wiper arm on the windscreen or rear window is folded back before a wiper blade has been fitted, the window may be damaged by the force of the impact.

- ▶ Never fold the wiper arm on the windscreen or rear window back until a wiper blade has been fitted. Keep hold of the wiper arm when replacing a wiper blade.

**!** **NOTE** Damage to bonnet or windscreen wipers when opening the bonnet

If the windscreen wipers have been folded back from the windscreen when the bonnet is opened, the windscreen wipers or the bonnet may be damaged.

- ▶ Ensure that the windscreen wipers have not been folded back from the windscreen.

### Removing the wiper blades

- ▶ Fold the wiper arms away from the windscreen.

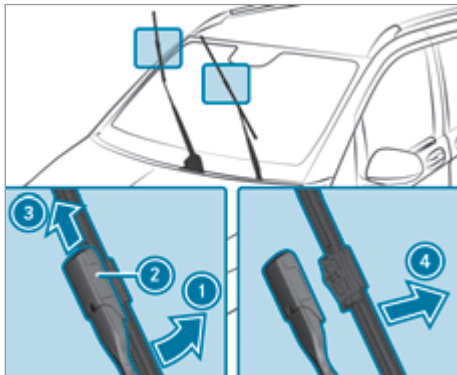

- ▶ Hold the wiper arm with one hand. With the other hand, turn the wiper blade in the direction of arrow ① away from the wiper arm as far as it will go.
- ▶ Slide catch ② in the direction of arrow ③ until it engages in the removal position.
- ▶ Remove the wiper blade from the wiper arm in the direction of arrow ④.

### Fitting the wiper blades

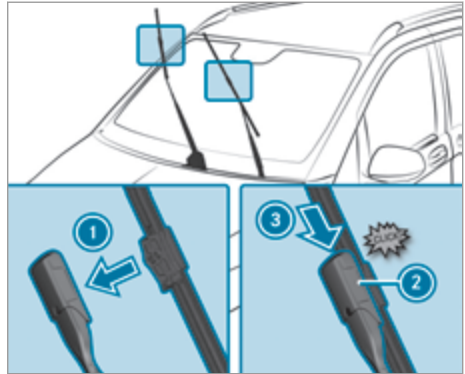

- ▶ Insert the new wiper blade into the wiper arm in the direction of arrow ①.
- ▶ Slide catch ② in the direction of arrow ③ until it engages in the locking position.
- ▶ Make sure that the wiper blade is seated correctly.
- ▶ Fold the wiper arms back onto the windscreen.

### Maintenance display

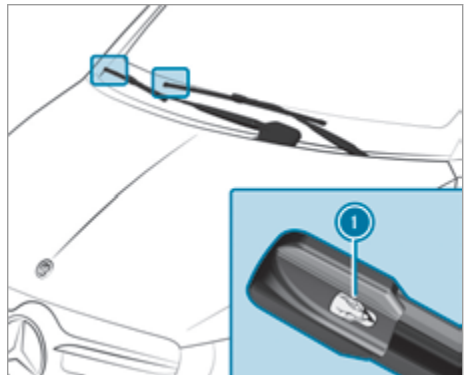

- ▶ Remove protective film ① from the maintenance displays on the tips of the newly fitted wiper blades.

If the colour of the maintenance display changes from black to yellow, the wiper blades should be replaced.

- ① The time until the colour changes varies depending on the usage conditions.

## Replacing rear window wiper blades

### Tailgate

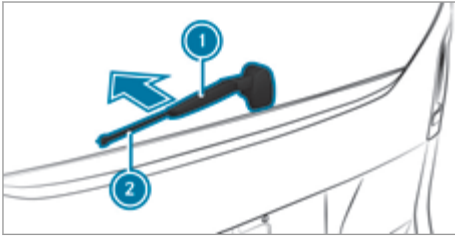

- ▶ Fold wiper arm ① away from the rear window until it engages in the replacement position.
- ▶ Keep hold of wiper arm ① and pull wiper blade ② off the wiper arm in the direction of the arrow.
- ▶ Place new wiper blade ② on wiper arm ①.
- ▶ Keep hold of wiper arm ① and push wiper blade ② in the opposite direction to the arrow until it engages.
- ▶ Make sure that wiper blade ② is seated correctly.
- ▶ Fold wiper arm ① back onto the rear window.

## Mirrors

### Operating the outside mirrors

- ⚠ **WARNING** Risk of accident due to adjusting the vehicle settings while the vehicle is in motion

You could lose control of the vehicle in the following situations in particular:

- if you adjust the driver's seat, the head restraint, the steering wheel or the mirror while the vehicle is in motion
- if you fasten your seat belt while the vehicle is in motion

▶ Before starting the vehicle: in particular, adjust the driver's seat, head restraint, steering wheel and mirror, and fasten your seat belt.

- ⚠ **WARNING** Risk of accident due to misjudgement of distance when using the outside mirror

The outside mirrors reflect objects on a smaller scale. The objects in view are in fact closer than they appear.

▶ Therefore, always look over your shoulder in order to ensure that you are aware of the actual distance between you and the road users driving behind you.

### Adjusting the outside mirrors electrically

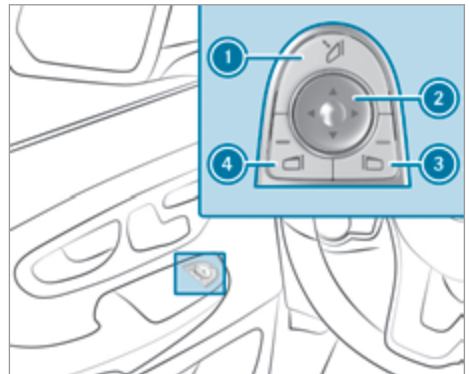

- ▶ Switch on the power supply or the vehicle.
- ▶ Press button ③ or ④ to select the outside mirror to be adjusted.
- ▶ Set the position of the mirror glass using button ②.

### Folding the electric outside mirrors in/out

- ⚠ **NOTE** Damage to the electric outside mirrors

If you fold or unfold the electric outside mirrors by hand, you may damage the outside mirrors and the outside mirrors will not engage properly.

If the outside mirrors are not folded in when the vehicle is washed in an automatic car wash, the brushes may forcibly fold in and damage the outside mirrors.

- ▶ Fold the outside mirrors in and out electrically only.
- ▶ Fold in the outside mirrors before washing the vehicle in an automatic car wash.

- ▶ Switch on the power supply or the vehicle.

- ▶ Briefly press button ①.

You will no longer be able to fold in the outside mirrors once you reach a speed greater than 47 km/h.

### Engaging the outside mirrors

If an outside mirror has been forcibly disengaged forwards or backwards, proceed as follows.

- ▶ Press and hold button ① until you hear a click followed by the mirror audibly engaging in position.  
The mirror housing will now be engaged and you will be able to adjust the outside mirrors as normal.



### Resetting the outside mirrors

- ① If the battery has been disconnected or completely discharged, the outside mirrors must be reset. Only then will the automatic mirror folding function work properly.
- ▶ Switch on the power supply or the vehicle.
- ▶ Briefly press button ①.

### Heating the outside mirrors

**Vehicles without a rear window heater:** at temperatures below 15°C, the mirror heater will automatically switch on permanently once the vehicle has been started.

**Vehicles with a rear window heater:** at temperatures below 15°C, the mirror heater will automatically switch on for ten minutes once the vehicle has been started. The mirror heater can also be switched on together with the rear window heater.

- ▶ Switch on the vehicle.
- ▶ Press the  button on the climate control operating unit.  
The indicator lamp on the  button will light up and the mirror heater will be switched on together with the rear window heater.

### Using the digital rearview mirror

The vehicle may be fitted with a digital inside rearview mirror. This uses a camera in the rear window and a display integrated in the mirror to provide a better view to the rear. The rearview mirror can be used either as a standard rearview mirror or as a display.

To prevent glare from the digital rearview mirror, first set the digital rearview mirror as the standard rearview mirror.

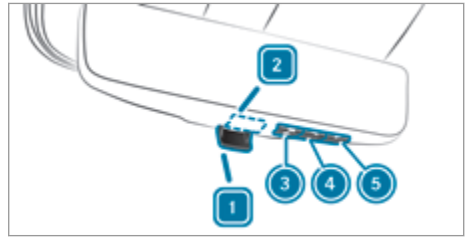

Certain types of sunlight, e.g. sun low on the horizon or light from another intense light source, can reduce the display's contrast and cause it to become too bright. In such situations, objects on the display may be obscured or difficult to see. In these cases, be particularly careful and adapt your driving style accordingly.

Drivers must always wear the necessary personal visual aids required for them to drive a vehicle. Drivers with presbyopia (age-related long-sightedness) should, if necessary, wear visual aids with multifocal lenses to be sufficiently able to see traffic including via the displays.

- ① If the camera in the rear window is dirty, operate the rear window wiper with washer fluid (→ page 120) or clean the rear window manually. Observe the notes on cleaning the digital rearview mirror (→ page 236).

- ▶ **To use the standard rearview mirror:** move the switch to position ①.
- ▶ **To use the display:** move the switch to position ②.

### Adjusting the display brightness

- ① The digital rearview mirror is equipped with light sensors on the front and back and automatically adjusts the brightness of the display to the lighting conditions. Do not cover the light sensors, e.g. with a sticker.

- ▶ Press menu button ③ once.
  - ▶ Press button ④ to reduce the display brightness.
- or
- ▶ Press button ⑤ to increase the display brightness.

### Adjusting the angle of the camera

- ▶ Press menu button ③ twice.
  - ▶ Press button ④ to move the angle downwards.
- or
- ▶ Press button ⑤ to move the angle upwards.

### Error mode of the digital rearview mirror

If a system error occurs, e.g. if the camera fails, a crossed-out camera will appear at the top left of the display and no camera image will be visible in the mirror.

- ▶ Switch to the standard rearview mirror if there is a system error.

### Automatic anti-dazzle mirrors function

**⚠ WARNING** Risk of acid burns and poisoning due to the anti-dazzle mirror electrolyte

Electrolyte may escape if the glass in an automatic anti-dazzle mirror breaks.

The electrolyte is hazardous to health and causes irritation. It must not come into contact with your skin, eyes, respiratory organs or clothing or be swallowed.

- ▶ If you come into contact with electrolyte, observe the following:
  - Immediately rinse the electrolyte from your skin with water and seek medical attention.
  - If electrolyte comes into contact with your eyes, immediately rinse them thoroughly with clean water and seek medical attention.
  - If the electrolyte is swallowed, immediately rinse your mouth out thoroughly. Do not induce vomiting. Seek medical attention immediately.
  - Immediately change out of clothing which has been contaminated with electrolyte.
  - If an allergic reaction occurs, seek medical attention immediately.

The inside rearview mirror and the outside mirror on the driver's side will automatically go into anti-dazzle mode if light from a headlamp hits the sensor on the inside rearview mirror.

### System limits

The system will not go into anti-dazzle mode if:

- the vehicle is switched off
- reverse gear is engaged.
- the interior lighting is switched on.
- the incident light from the headlamps is blocked by objects in the load compartment,

for example, and does not hit the sensor on the inside rearview mirror.

### Operating sun visors

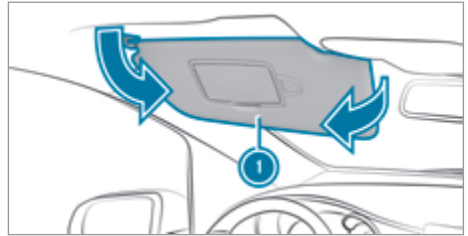

- ▶ **Glare from front:** Fold the sun visor ① downwards.
- ▶ **Glare from the side:** Swivel the sun visor ① to the side.

## Overview of climate control systems

### TEMPMATIC overview

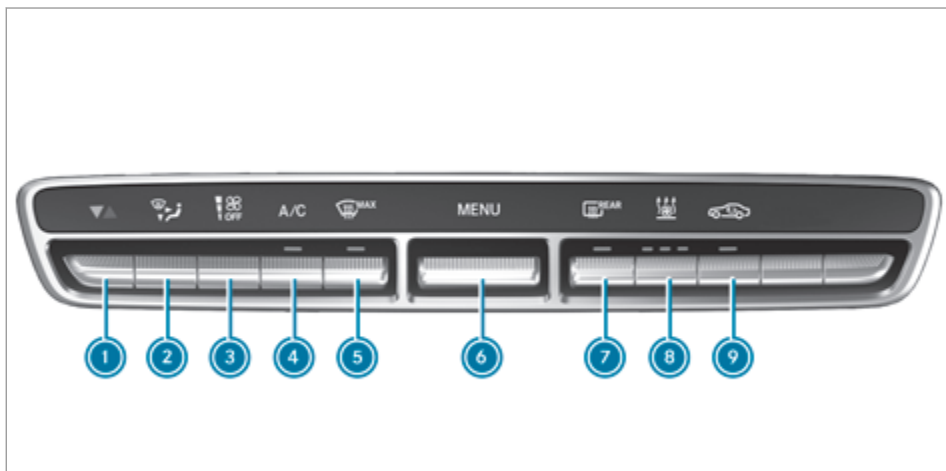

- ① Sets the temperature (→ page 129)
- ② Sets the air distribution (→ page 128)
- ③ Sets the airflow (→ page 128)
- ④ Switches cooling with air dehumidification on/off (→ page 127)
- ⑤ Demists the windscreen (→ page 129)
- ⑥ Calls up the air conditioning menu of the multimedia system
- ⑦ Switches the rear window heater and mirror heater on/off (→ page 130)
- ⑧ Switches the hot-water auxiliary heater (stationary heater) on/off (→ page 133)
- ⑨ Switches air-recirculation mode on/off manually (→ page 129)

## THERMOTRONIC overview

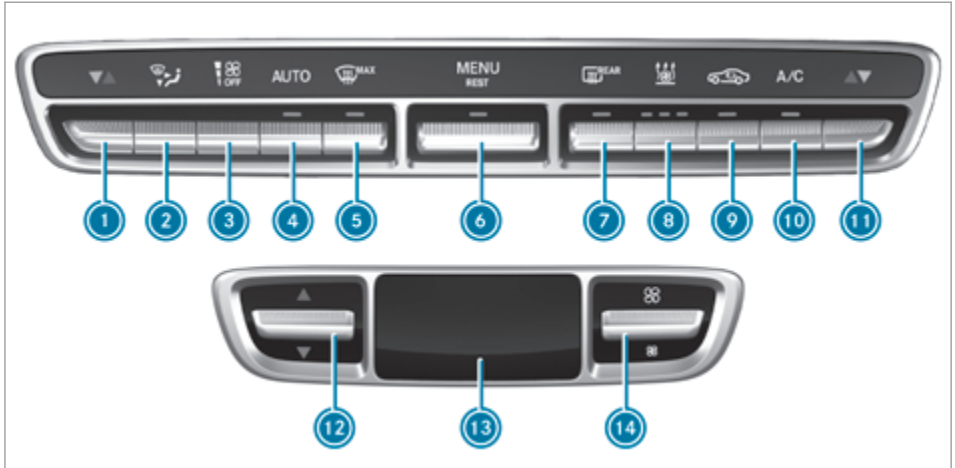

Vehicles with a hot-water auxiliary heater (stationary heater)

Front operating unit:

- ① Sets the temperature on the left (→ page 129)
- ② Sets the air distribution (→ page 128)
- ③ Sets the airflow (→ page 128)
- ④ Sets climate control to automatic mode (→ page 128)
- ⑤ Demists the windscreen (→ page 129)
- ⑥ Calls up the air conditioning menu of the multimedia system  
Switches residual heat utilisation on/off (→ page 130)
- ⑦ Switches the rear window heater and mirror heater on/off (→ page 130)
- ⑧ Switches the hot-water auxiliary heater on/off (→ page 133)
- ⑨ Switches air-recirculation mode on/off manually (→ page 129)
- ⑩ Switches cooling with air dehumidification on/off (→ page 127)
- ⑪ Sets the temperature on the right (→ page 129)

Rear operating unit:

- ⑫ Sets the temperature (→ page 129)
- ⑬ Display
- ⑭ Sets the airflow (→ page 128)

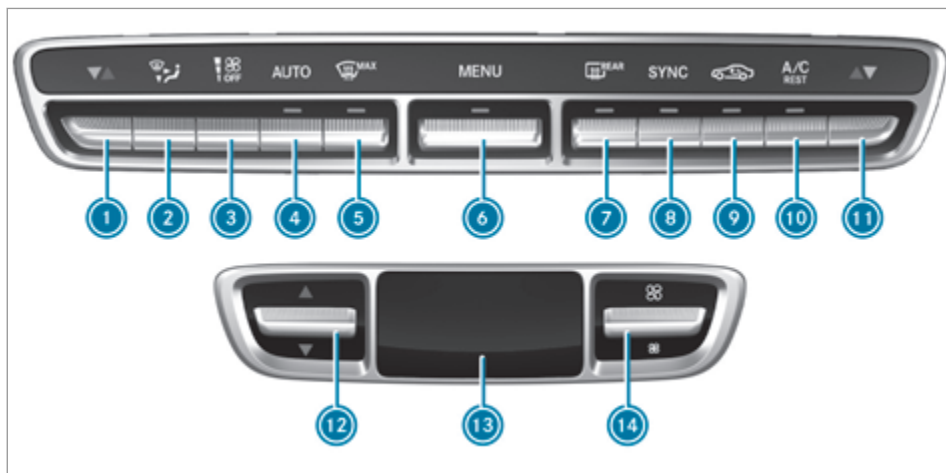

Vehicles without a hot-water auxiliary heater (stationary heater)

Front operating unit:

- ① Sets the temperature on the left (→ page 129)
  - ② Sets the air distribution (→ page 128)
  - ③ Sets the airflow (→ page 128)
  - ④ **AUTO** Automatically regulates climate control (→ page 128)
  - ⑤ Demists the windscreen (→ page 129)
  - ⑥ **MENU** Calls up the air conditioning menu of the multimedia system
  - ⑦ Switches the rear window heater and mirror heater on/off (→ page 130)
  - ⑧ **SYNC** Switching the synchronisation function on/off (→ page 129)
  - ⑨ Switches air-recirculation mode on/off manually (→ page 129)
  - ⑩ Switches cooling with air dehumidification on/off (→ page 127)
- Switches residual heat utilisation on/off (→ page 130)

- ⑪ Sets the temperature on the right (→ page 129)

Rear operating unit:

- ⑫ Sets the temperature (→ page 129)
- ⑬ Display
- ⑭ Sets the airflow (→ page 128)

▶ **To switch on:** press the top or bottom section of the **MENU** rocker switch or press . The multimedia system air conditioning menu will open.

or

▶ Set the airflow to level **1** or higher using the rocker switch.

▶ **To switch off:** press the top or bottom section of the **MENU** rocker switch or press .

or

▶ Set the airflow to level **0** using the rocker switch.

ⓘ When climate control is switched off, "OFF" will appear on the display of the rear operating unit.

ⓘ When the vehicle is started, the climate control settings most recently selected will be adopted automatically.

### Switching the A/C function on/off

#### Requirements:

- The climate control system has been switched on (→ page 127).
- The vehicle has been started.

When the "Cooling with air dehumidification" function is switched on, the air inside the vehicle is cooled and dehumidified according to the temperature selected.





The function can be activated or deactivated only in the air conditioning menu, but not in the air con-

## Operating climate control systems

### Switching the climate control system on/off



- ▶ Switch on the vehicle.

ditioning menu for the rear air conditioning system (second menu level).

- ▶ Set the airflow to level **1** or higher using the  rocker switch.
  - ▶ Press the top or bottom section of the  or  rocker switch.
- When the indicator lamp above the  or  rocker switch lights up, the "Cooling with air dehumidification" function is switched on.

or

- ▶ Switch the function on and off via the air conditioning menu of the multimedia system.

When the indicator lamp above the  or  rocker switch flashes three times, the function is switched off due to a defect. Have the climate control system checked at a qualified specialist workshop.

- ⓘ Switch off the A/C function only briefly. Otherwise, the windows could mist up more quickly.
- ⓘ Condensation may leak from the underside of the vehicle in cooling mode. This is not a sign of a defect.

### Automatically regulating climate control



#### Requirements:

- The climate control system has been switched on (→ page 127).

#### THERMOTRONIC automatic climate control

When THERMOTRONIC automatic climate control is in automatic mode, the set temperature will automatically be kept constant. The system automatically regulates the temperature of the dispensed air, the airflow and the air distribution.

Automatic mode can be activated or deactivated only in the climate control menu and not in the climate control menu for rear-compartment air conditioning (second menu level).









- ▶ **To switch automatic mode on/off:** press the top or bottom section of the  rocker switch.  
When the indicator lamp above the  rocker switch lights up, automatic mode is switched on.

In automatic mode, if you adjust the airflow or air distribution manually, the indicator lamp above the  rocker switch will go out. The function that has not been changed manually, however, will continue to be regulated automatically. When the manually changed function switches back to automatic

mode, the indicator lamp above the  rocker switch will light up again.



### Information on the air distribution settings

THERMATIC air-conditioning system and THERMOTRONIC automatic climate control

-  Directs air to the demister vents
-  Directs air to the demister, centre and side air vents
-  Directs air to the demister, centre, side and footwell vents
-  Directs air to the demister and footwell vents
-  Directs air to the centre and side air vents
-  Directs air to the centre, side and footwell vents
-  Directs air to the footwell vents
-  Controls air distribution automatically

### Setting the air distribution

#### Requirements:

- The climate control system is switched on.
- ▶ Press rocker switch  up or down. The various air distribution settings appear in the air conditioning menu of the multimedia system.
- ▶ Press the  rocker switch up or down until the desired setting is reached.

#### Vehicles with rear climate control

When the rear air conditioning system is switched on, the air distribution setting on the control panel also applies to rear climate control.

This also applies to the automatic mode of THERMOTRONIC automatic climate control. The air is then automatically directed to the footwell and/or the headroom of the rear compartment.

### Setting the airflow

#### Requirements:

- The climate control system is switched on.
- ▶ **To increase or decrease:** press the top or bottom section of the  rocker switch.

Vehicles with rear climate control: use the air conditioning menu of the multimedia system or the

rear control panel to set the airflow for the rear compartment.

### Setting the temperature

#### Requirements:

- The climate control system is switched on.

▶ **To increase or decrease:** press the top or bottom section of the  rocker switch.

Vehicles with rear climate control: use the air conditioning menu of the multimedia system or the rear control panel to set the temperature for the rear compartment.

### Switching the synchronisation function on/off

#### Requirements:

- The climate control system has been switched on (→ page 127).

The temperature can be set centrally using the synchronisation function. The temperature setting for the driver's side will then be adopted for the front passenger side and, in vehicles with rear climate control, the rear compartment as well.

#### TEMPMATIC and THERMOTRONIC with hot-water auxiliary heater

▶ Switch the "Synchronisation" function on and off via the air conditioning menu of the multimedia system.

#### THERMOTRONIC without hot-water auxiliary heater

▶ Press the top or bottom section of rocker switch .

The synchronisation function will be switched off if the settings for the front passenger side or rear compartment are changed.

### Demisting the windscreen

You can use this function to defrost and demist the windscreen and the front side windows from the inside. Switch off the "Demist windscreen" function as soon as the windscreen is clear.

 Vehicles with THERMOTRONIC: if the vehicle detects mist on the windows, the function will automatically be switched on.

▶ Switch on climate control (→ page 127).

▶ **To switch on/off:** push the top or bottom section of the  rocker switch on the front control panel.

If the indicator lamp above the  rocker switch lights up, the function has been switched on. The current air-conditioning settings will be deactivated.

The temperature, airflow and air distribution will be regulated automatically to optimise the demisting effect. Air-recirculation mode will be deactivated.

When you enable automatic mode, the "Demist windscreen" function will switch off automatically.

When you switch off the "Demist windscreen" function, the previous settings for automatic climate control will be applied again.

Note the following exceptions:

- Air-recirculation mode will remain switched off.
- If the A/C function has been automatically activated, it will remain active.

### Switching air-recirculation mode on/off

When air-recirculation mode is switched on, the windows may mist up more quickly. Switch on air-recirculation mode only briefly.

▶ Press the top or bottom section of the  rocker switch.

When the indicator lamp above the  rocker switch lights up, air-recirculation mode is switched on.

Air-recirculation mode will automatically switch on in the following cases:

- in high outside temperatures
- while the vehicle is driving through a tunnel (vehicles with THERMOTRONIC automatic climate control and navigation only)

After approximately 30 minutes, outside air will automatically be introduced again.

Air-recirculation mode will automatically switch off in the following cases:

- after approximately five minutes at outside temperatures below approximately 7°C
- after approximately five minutes when the "Cooling with air dehumidification" function is deactivated
- after approximately 30 minutes at outside temperatures above approximately 7°C and when

the "Cooling with air dehumidification" function is switched on.

### Convenience opening/closing

**⚠ WARNING** Risk of entrapment due to not paying attention during convenience closing

When the convenience closing feature is operating, parts of the body could become trapped in the closing area of the side windows.

- ▶ When the convenience closing feature is operating, monitor the entire closing process and make sure that no body parts are in the closing area.

**⚠ WARNING** Risk of entrapment when opening a side window





When opening a side window, parts of the body could be drawn in or become trapped between the side window and window frame.

- ▶ When opening, make sure that nobody is touching the side window.
- ▶ Release the button immediately if somebody becomes trapped.

- ▶ **Convenience closing with the air recirculation rocker switch:** press and hold the  rocker switch up or down until the side windows close automatically.

The indicator lamp above the  rocker switch lights up. The original position of the side windows is stored. Air-recirculation mode is activated.

If you open the side windows manually after using convenience closing, they first open automatically to the original position before convenience closing.

- ▶ **To interrupt convenience closing:** release the rocker  switch.
- ▶ **Convenience opening with the air-recirculation rocker switch:** press and hold the  rocker switch up or down until the side windows open automatically. The indicator lamp above the  rocker switch goes out. Air-recirculation mode will be deactivated.
- ▶ **To interrupt convenience opening:** release the  rocker switch.



- ▶ **Pre-entry climate control and convenience opening with the key:** press and hold the  button on the key.

The side windows open automatically and the blower of the climate control system is activated.

- ▶ **To interrupt convenience opening:** release the  button.

### Switching the rear window heater on/off









The rear window heater consumes a lot of electricity. You should therefore switch off the rear window heater as soon as the rear window is clear.

- ▶ Switch on the vehicle.
- ▶ Press the top or bottom of the  rocker switch. If the indicator lamp above the  rocker switch lights up, the rear window heater is switched on.

The rear window heater will switch off automatically after a few minutes.

### Switching the residual heat utilisation on/off

When the vehicle is switched off, it is possible to make use of the residual heat of the engine to heat or ventilate the vehicle interior for approximately 30 minutes. The heating or ventilation time depends on the set vehicle interior temperature.

- ▶ Switch off the vehicle or remove the key.
- ▶ **To switch on:** press the top or bottom section of the  rocker switch or press . When residual heat utilisation is switched on, the indicator lamp above the  rocker switch or the  button will light up. The blower will run at a low speed regardless of the airflow setting. If the "Residual heat" function is switched on at high outside temperatures, only the stationary ventilation will be switched on. The blower will then run at medium speed.
- ▶ **To switch off:** press the top or bottom section of the  rocker switch or press  again. The indicator lamp above the  rocker switch or the  button goes out.

Residual heat utilisation will switch off automatically in the following cases:

- after a running time of approximately 30 minutes
- if the starter battery's charge status is too low

- if the vehicle is switched on
- when the hot-water auxiliary heater is switched on

## Operating air vents

### Adjusting the air vents

**⚠ WARNING** Risk of burns or frostbite due to being too close to the air vents

Very hot or very cold air can flow from the air vents.

- ▶ Make sure that all vehicle occupants always maintain a sufficient distance from the air vents.
- ▶ If necessary, direct the airflow to another area of the vehicle interior.

### Adjusting the centre air vents

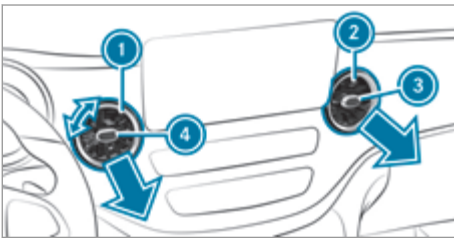

- ▶ **To open/close:** turn controller ③ or ④ to the left or right as far as it will go.
- ▶ **To adjust the airflow direction:** hold centre air vent ① or ② by controller ③ or ④ and move it up or down or to the left or right.

### Adjusting the side air vents:

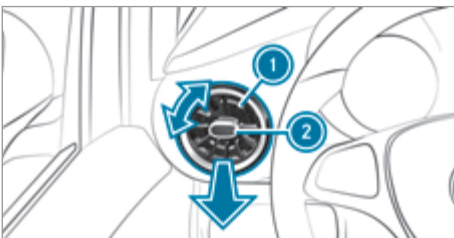

- ▶ **To open/close:** turn controller ② clockwise or anti-clockwise as far as it will go.
- ▶ **To adjust the airflow direction:** hold side air vent ① by controller ② and move it up or down or to the left or right.

### Opening/closing the rear air vents:

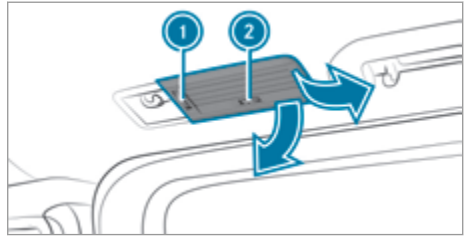

- ① Adjustment wheel for vertically adjusting and regulating airflow
- ② Adjustment wheel for horizontally adjusting airflow

The air vents can be adjusted only on vehicles with rear-compartment air conditioning.

- ▶ **To open:** turn adjustment wheel ① of the rear air vent to the centre position.
- ▶ **To close:** turn adjustment wheel ① to the upper or lower end position.

## Auxiliary heating

### Notes on auxiliary heating

**⚠ DANGER** Risk of fatal injury due to poisonous exhaust gases

If the tailpipe is blocked or sufficient ventilation is not possible, poisonous exhaust gases such as carbon monoxide may enter the vehicle. This is the case in enclosed spaces or if the vehicle gets stuck in snow, for example.

- ▶ Always switch the stationary heater off in enclosed spaces without an air extraction system, e.g. in garages.
- ▶ Keep the tailpipe and the area around the vehicle free from snow when the engine or the stationary heater is running.
- ▶ Open a window on the side of the vehicle facing away from the wind to ensure an adequate supply of fresh air.

**⚠ WARNING** Risk of fire due to hot stationary heater components and exhaust gases

Flammable materials such as leaves, grass or twigs may ignite.

- ▶ When the stationary heater is switched on, make sure that:

- hot vehicle parts do not come into contact with flammable materials.
- the exhaust gas can flow out of the stationary heater exhaust pipe unhindered.
- the exhaust gas does not come into contact with flammable materials.

The heater for the auxiliary heating is fitted at the front of the vehicle underbody. The emissions outlet is on the left side of the vehicle below the front door.

**⚠ WARNING** Risk of poisoning during work on the auxiliary warm-air heater

If work on the heat exchanger of the auxiliary warm-air heater is not performed correctly, exhaust fumes could leak into the passenger compartment.

- ▶ Have all work on the auxiliary warm-air heater carried out at a qualified specialist workshop.

If you are transporting hazardous materials, comply with the relevant safety regulations. Place objects a sufficient distance from the auxiliary heating outlet opening.

**! NOTE** Damage to the auxiliary heating due to overheating

If the flow of hot air is blocked, the auxiliary heating may overheat and switch off.

- ▶ Do not block the flow of hot air.

**! NOTE** Battery discharge caused by stationary heater or stationary ventilation operation

Operating the stationary heater or stationary ventilation drains the battery.

- ▶ After heating or ventilating the vehicle twice, drive for a longer period of time.

Your vehicle may be equipped with either a hot-water auxiliary heater or an auxiliary warm-air heater.

The **hot-water auxiliary heater** is adjusted and operated using the  rocker switch on the climate control system operating unit and via the multimedia system or by remote control.

The **auxiliary warm-air heater** is adjusted and operated via the switch clock on the lower centre console.

### Hot-water auxiliary heater

#### Function of the hot-water auxiliary heater

Observe the notes on auxiliary heating (→ page 131).

The hot-water auxiliary heater has a heater booster, stationary heater and stationary ventilation function.

The stationary heater automatically adapts its operating mode to changes in outside temperature and weather conditions. It is therefore possible that the stationary heater may switch from ventilation to heating mode or from heating to ventilation mode.

The stationary heater will automatically switch itself off after a maximum of 50 minutes. The heater booster function helps to heat up the vehicle while the engine is running and at low outside temperatures.

You can set up to three departure times for pre-entry climate control by remote control or via the multimedia system. The switch-on time is then calculated based on the outside temperature and the activated departure time. This means that your vehicle is preheated or precooled by the set departure time.

If the departure time is reached and the vehicle is not started, the auxiliary heating will continue to run for approximately five more minutes. It will then switch off automatically.

When the auxiliary heating is heating and the vehicle is started, the heater booster function of the auxiliary heating will be activated.

When the auxiliary heating is ventilating and the vehicle is started, the auxiliary heating will be automatically switched off.

## Switching the hot-water auxiliary heater on/off with the button



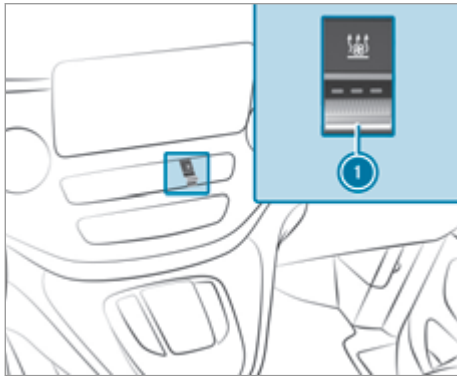

### Requirements:

- The fuel tank is filled above the reserve level.



The coloured indicator lamps above the  rocker switch have the following meanings:

- Blue – stationary ventilation is switched on
- Red – the stationary heater is switched on
- Yellow – a departure time is preselected

- ▶ **To switch on:** press the top or bottom section of rocker switch . The red or blue indicator lamp above rocker switch  will light up. The multimedia system will be activated for approximately one minute.
- ▶ Set the desired temperature via the multimedia system.
- ▶ **To switch off:** press the top or bottom section of rocker switch  again. The red or blue indicator lamp above rocker switch  will go out.

## Adjusting the hot-water auxiliary heater by remote control

### Requirements:











- The fuel tank is filled above the reserve level.

### Switching on immediately







- ▶ Press and hold the  button until the "ON" message appears on the remote control's display.

### Setting the departure time

- ▶ Briefly press the  button.
- ▶ Continue to press the  or  button until the time to be changed appears on the display.
- ▶ Press the  and  buttons simultaneously. The  symbol on the remote control display will flash.
- ▶ Set the required departure time with the  and  buttons.
- ▶ Press the  and  buttons simultaneously. The new departure time will be saved.

Up to three departure times can be saved.

### Activating the departure time

- ▶ Briefly press the  button.
- ▶ Select the required departure time with the  and  buttons.
- ▶ Press and hold the  button. The  symbol, the departure time and, depending on the selected departure time, letter **A**, **B** or **C** will appear on the remote control's display.

**To deactivate the departure time:**

- ▶ Select the desired display and press and hold the **[OFF]** button. "OFF" will appear on the display.

**Checking the status of the active stationary heater**

- ▶ Briefly press the **[ON]** button.

**Switching off immediately**

- ▶ Press and hold the **[OFF]** button.

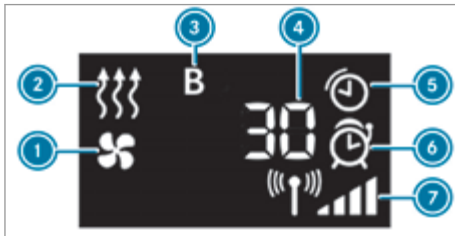
**Overview of remote control displays (stationary heating/ventilation)**

- ① Stationary ventilation switched on
- ② Stationary heating switched on
- ③ Selected departure time
- ④ Remaining stationary heating or ventilation time (in minutes)
- ⑤ Stationary heating or ventilation active
- ⑥ Departure time activated
- ⑦ Signal strength

Further display options:

- **Time:** the selected departure time.
- **0 minutes:** the running time of the stationary heating extends as the operating temperature has not yet been reached when the engine is started.
- **OFF:** stationary heating or ventilation has been switched off.

**Changing the remote control's battery (stationary heater)**

**⚠ DANGER** Risk of fatal injuries due to swallowing batteries

Batteries contain toxic and corrosive substances. Swallowing batteries may cause severe internal burns within two hours.

There is a risk of fatal injuries.

- ▶ Keep batteries out of the reach of children.
- ▶ If the battery cover does not close securely, do not continue to use the remote control, and keep it out of the reach of children.
- ▶ If batteries are swallowed, seek medical attention immediately.

**♻ ENVIRONMENTAL NOTE** Environmental damage due to improper disposal of batteries



Batteries contain toxic and corrosive substances.



Take discharged batteries to a qualified specialist workshop or to a collection point for used batteries.

**Requirements**

- A CR2450 lithium battery is available.

Mercedes-Benz recommends that you have the battery replaced by a qualified specialist workshop.

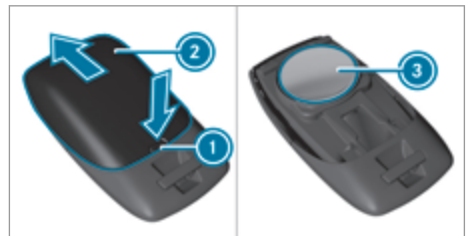

- ▶ Push a pointed object into recess ①.
- ▶ Slide battery cover ② backwards in the direction of the arrow.
- ▶ Insert new battery ③ with the lettering facing upwards.
- ▶ Slide battery cover ② onto the remote control in the opposite direction to the arrow until the battery cover engages.

## Rectifying problems with the hot-water auxiliary heater

### FAIL appears on the remote control display

Possible cause:

- Signal transmission between transmitter and receiver is malfunctioning.
- ▶ Change your position in relation to the vehicle, moving closer if necessary.

### FAIL appears on the remote control display

Possible cause:

- The starter battery is not sufficiently charged.
- ▶ Charge the starter battery.

Possible cause:

- The fuel tank is not filled up to the reserve level.
- ▶ Refuel at the nearest filling station.

### FAIL appears on the remote control display

Possible cause:

- The auxiliary heating has malfunctioned.
- ▶ Have the auxiliary heating checked at a qualified specialist workshop.

## Auxiliary warm-air heater

### Function of the auxiliary warm-air heater

Observe the notes on auxiliary heating (→ page 131).

The air-intake opening for the auxiliary warm-air heater is located on the inner side of the left front seat base. The warm-air outlet is on the rear side of the left front seat.

The auxiliary warm-air heater supplements the climate control system of your vehicle and has an auxiliary heating function.

The stationary heater will switch off automatically when the vehicle is switched off or when the set heating duration has elapsed.

The immediate heating mode of the auxiliary heating supports the climate control system when the engine is running and the outside temperature is low.

The switch clock for the auxiliary warm-air heater is located in the lower centre console.

You can use the switch clock to set up to three departure times for pre-entry climate control.

## Switch clock overview (auxiliary warm-air heater)

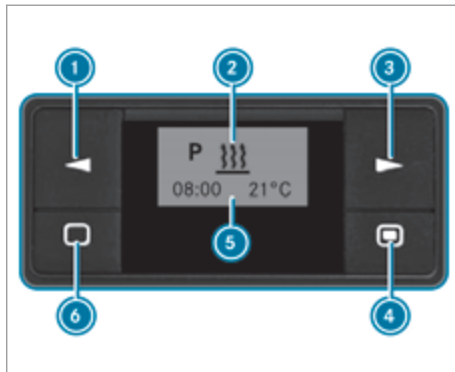

- ① Select option / change values
- ② Menu bar
- ③ Select option
- ④ Pressing briefly: confirms a selection or setting  
Pressing and holding: switches immediate heating mode on/off
- ⑤ Status bar
- ⑥ Pressing briefly: switches switch clock on / cancels or terminates the settings in a menu  
Pressing and holding: terminates all functions

### Switching the switch clock on (auxiliary warm-air heater)

- ▶ Press button ⑥.



- ⓘ The switch clock will switch to standby mode after ten seconds. The display will go off.

### Setting the switch clock (auxiliary warm-air heater)

#### Setting the time

You must reset the day, time and default value for the operating duration in the following cases:

- initial operation
- after a voltage supply interruption (e.g. if the battery has been disconnected)
- after a malfunction

- ▶ Press button ① or ③ until  flashes on menu bar ②.
- ▶ Press button ④.
- ▶ Press button ① or ③ until  flashes.
- ▶ Press button ④.
- ▶ Use button ① or ③ to set the hours.

- ▶ Press button ④.
- ▶ Use button ① or ③ to set the minutes.
- ▶ Press button ④.



### Setting the time format

- ▶ Press button ① or ③ until  flashes on menu bar ②.
- ▶ Press button ④.
- ▶ Press button ① or ③ until the symbol for the time format flashes.
- ▶ Press button ④.
- ▶ Select the desired time format using button ① or ③.
- ▶ Press button ④.

### Setting the day

- ▶ Press button ① or ③ until  flashes on menu bar ②.
- ▶ Press button ④.
- ▶ Press button ① or ③ until the symbol for the day flashes.
- ▶ Press button ④.
- ▶ Use button ① or ③ to select the desired day of the week.
- ▶ Press button ④.

### Switching immediate heating mode on/off

- ▶ **To switch on:** press button ④ until  flashes on menu bar ②.  
On will briefly appear on the display, followed by the remaining operating duration or the  symbol for continuous operation.
- ▶ **To switch off:** press button ④ until Off appears on the display.

### Setting the departure time (auxiliary warm-air heater)

You can set three departure times with the switch clock. Following malfunctions or if the battery has been disconnected, you will need to re-set the departure times.

### Selecting a program memory

- ▶ Press button ① or ③ until **P** flashes on menu bar ②.
  - ▶ Press button ④.
- The numbers of the program memories are shown on status bar ⑤. The tick denotes activated program memories.

- ▶ Use button ① or ③ to select the desired program memory.
- ▶ Press button ④.

### Activating/deactivating program memories

- ▶ Use button ① or ③ to select On or Off.
- ▶ Press button ④.

### Editing program memories

- ▶ Use button ① or ③ to select .
- ▶ Press button ④.
- ▶ Set the day of the week and the time (→ page 135).

### Setting the temperature and operating duration (auxiliary warm-air heater)

- ▶ Press button ④.
- ▶ Set the temperature with button ① or ③.
- ▶ Press button ④.
- ▶ Set the operating duration with button ① or ③ or select the  symbol for continuous operation.
- ▶ Press button ④.

- ① The operating duration set is the default setting for immediate heating mode. You can set the operating duration within a range of 10 to 120 minutes or to continuous operation.

### Rectifying problems with the auxiliary warm-air heater

#### The message **ERROR** appears on the switch clock's display.

Possible cause:

- A malfunction has occurred.
- ▶ Have the auxiliary heating checked at a qualified specialist workshop.

#### The message **INIT** appears on the switch clock's display.

Possible cause:

- The power supply has been interrupted. All saved settings have been deleted.  
Automatic hardware detection is currently active.
- ▶ When automatic hardware detection is complete, set the day of the week, time and operating duration (→ page 135).
- ▶ Set the departure time (→ page 136).

**Auxiliary heating automatically switches off and/or cannot be switched on.**

Possible cause:

- The undervoltage protection system integrated in the control unit is switching the auxiliary heating off as the on-board electrical system voltage is below 10 V.

▶ Have the alternator and the battery checked.

Possible cause:

- The electrical fuse has blown.

▶ Replace the electrical fuse; see "Fuse assignment" supplement.

▶ Have the cause of the faulty fuse investigated at a qualified specialist workshop.

**The hot-air auxiliary heater has overheated**

Possible cause:

- The air ducts are clogged.

▶ Ensure that the flow of hot air is not blocked.

▶ Have the auxiliary heating checked at a qualified specialist workshop.

## Driving

### Key positions

**⚠ WARNING** Risk of accident and injury due to leaving children unattended in the vehicle

If children are left unattended in the vehicle, they could, in particular:

- open doors, thereby endangering other persons or road users.
- get out and be struck by oncoming traffic.
- operate vehicle equipment and become trapped, for example.

In addition, the children could also set the vehicle in motion by, for example:

- releasing the parking brake.
- changing the transmission position.
- starting the vehicle.

- ▶ Never leave children unattended in the vehicle.
- ▶ When leaving the vehicle, always take the key with you and lock the vehicle.
- ▶ Keep the vehicle key out of the reach of children.

**⚠ DANGER** Risk of fatal injuries due to exhaust gases

Combustion engines emit poisonous exhaust gases such as carbon monoxide. Breathing in these exhaust gases is hazardous to health and results in poisoning.

- ▶ Never leave the engine and, if present, the stationary heater, running in an enclosed space without sufficient ventilation.

**⚠ WARNING** Risk of fire due to flammable material in the engine compartment or the exhaust system

Flammable materials may ignite.

- ▶ Therefore, check regularly that there are no flammable materials in the engine compartment or on the exhaust system.



- 0** Inserting/removing the key
- 1** Switching on the power supply
- 2** Switching on vehicle
- 3** Starting the vehicle

**i** If the key does not belong to the vehicle, it can still be turned in the ignition lock. The vehicle is not switched on and cannot be started.

- ▶ Insert the key into the ignition lock in position **0** and turn it to the desired position.

### Running-in notes

Protect the engine during the first 1,500 km by:

- driving at varying road and engine speeds.
- shifting to the next highest gear at the very latest when the needle reaches the last third before the red area in the rev counter.
- avoiding stress on the vehicle such as driving at full throttle.
- not shifting manually to a lower gear to brake.
- after 1,500 km, gradually increasing the engine speed and accelerating the vehicle up to full speed.
- **vehicles with automatic transmission:** not depressing the accelerator pedal beyond the pressure point (kickdown).

This also applies if the engine or parts of the drive-train have been replaced.

Also observe the following running-in notes:

- After the vehicle has been delivered or after repairs, the sensor system of some driving systems and driving safety systems adjusts itself automatically after the vehicle has been driven a certain distance. Full system effectiveness is not reached until the end of this teach-in process.
- New or exchanged brakepads, brake discs and tyres only provide optimal braking and bonding after several hundred kilometres. Until then,

compensate for the reduced braking effect by applying greater pressure to the brake pedal.

## Driving tips

### Notes on driving

#### **⚠ WARNING** Risk of accident due to objects in the driver's footwell

Objects in the driver's footwell may impede pedal travel or block a depressed pedal.

This jeopardises the operating and road safety of the vehicle.

- ▶ Stow all objects in the vehicle securely so that they cannot get into the driver's footwell.
- ▶ Ensure floor mats and carpets cannot slip and provide sufficient room for the pedals.
- ▶ Do not lay multiple floor mats or carpets on top of one another.

#### **⚠ WARNING** Risk of accident due to incorrect footwear

Incorrect footwear includes, for example:

- shoes with platform soles
- shoes with high heels
- slippers

There is a risk of an accident.

- ▶ Always wear suitable footwear so that you can operate the pedals safely.

#### **⚠ WARNING** Risk of accident when vehicle is switched off due to steering wheel locking

If you switch off the vehicle while it is stationary, you can no longer steer the vehicle.

- ▶ Before the vehicle begins to roll, switch on the vehicle to deactivate steering wheel locking.

#### **⚠ WARNING** Risk of accident if the vehicle is switched off while driving

If you switch off the vehicle while driving, safety functions are restricted or no longer available.

This may affect the power steering system and the brake force boosting, for example.

You will need to use considerably more force to steer and brake, for example.

- ▶ Do not switch off the vehicle while driving.

#### **⚠ DANGER** Risk of fatal injuries due to exhaust gases

Combustion engines emit poisonous exhaust gases such as carbon monoxide. Breathing in these exhaust gases is hazardous to health and results in poisoning.

- ▶ Never leave the engine and, if present, the stationary heater, running in an enclosed space without sufficient ventilation.

#### **⚠ WARNING** Risk of skidding and of an accident due to shifting down on slippery road surfaces

If you shift down on slippery road surfaces to increase the engine braking effect, the drive wheels may lose traction.

- ▶ Do not shift down on slippery road surfaces to increase the engine braking effect.

#### **⚠ DANGER** Risk of fatal injury due to poisonous exhaust gases

If the tailpipe is blocked or sufficient ventilation is not possible, poisonous exhaust gases such as carbon monoxide may enter the vehicle. This is the case, for example, if the vehicle gets stuck in the snow.

- ▶ Keep the tailpipe and the area around the vehicle free from snow when the engine or the stationary heater is running.
- ▶ Open a window on the side of the vehicle facing away from the wind to ensure an adequate supply of fresh air.

#### **! NOTE** Damage to the drivetrain and engine when pulling away

- ▶ Do not warm up the engine while the vehicle is stationary. Pull away immediately.
- ▶ Avoid high engine speeds and driving at full throttle until the engine has reached its operating temperature.

**!** **NOTE** Damage to the vehicle due to not observing the maximum permitted headroom clearance

If the vehicle height is greater than the maximum permitted headroom clearance, the roof and other parts of the vehicle may be damaged.

- ▶ Observe the signposted headroom clearance.
- ▶ If the vehicle height is greater than the permitted headroom clearance, do not enter.
- ▶ Observe the changed vehicle height with add-on roof equipment.

### Notes on short-distance trips

If the vehicle is predominantly used in short-distance driving, a fault in the automatic cleaning function of the diesel particulate filter can occur. Due to this, fuel may also accumulate in the engine oil and cause engine failure.

During automatic cleaning, extremely hot exhaust gases escape from the exhaust pipe. Maintain a distance of at least 1 m to other objects, e.g. parked vehicles, in order to avoid material damage.

If you mainly drive short distances, you should drive on a motorway or go for a country drive for 20 minutes every 500 km. This facilitates the regeneration of the diesel particulate filter.

### Information about transport by rail

Transporting your vehicle by rail may be subject to certain restrictions or require special measures to be taken in some countries due to varying tunnel heights and loading standards.

You can obtain information about this from a Mercedes-Benz Service Centre.

### Information on brakes

**!** **WARNING** Risk of accident due to the brake system overheating

If you leave your foot on the brake pedal when driving, the brake system may overheat.

This increases the braking distance and the brake system can even fail.

- ▶ Never use the brake pedal as a footrest.
- ▶ Do not depress the brake pedal and the accelerator pedal at the same time while driving.

**!** **NOTE** Causing wear to the brake linings by permanently depressing the brake pedal

- ▶ Do not permanently depress the brake pedal while driving.
- ▶ To use braking effect of the engine, shift to a lower gear in good time.

### Downhill gradients

On long and steep downhill gradients you should observe the following instructions:

- in vehicles with an automatic transmission, shift down to shift ranges **2** or **1** in good time so that the engine is running at a medium to high engine speed (→ page 145).
- in vehicles with a manual transmission, shift down to a lower gear in good time, so that the engine is running at a medium to high engine speed.

**i** Change the shift range in good time when cruise control or the limiter are activated. Observe the driving tips (→ page 139).

You thereby make use of the braking effect of the engine and do not have to brake as often to maintain the speed. This relieves the load on the service brake and prevents the brakes from overheating and wearing too quickly.

### Heavy and light loads

If the brakes have been subjected to a heavy load, do not stop the vehicle immediately. Drive on for a short while. The brakes cool down more quickly in the airflow.

If the brakes have been used only moderately, you should occasionally test their effectiveness. To do this, brake more firmly from a higher speed while paying attention to the traffic conditions. The brakes will grip better as a result.

### Wet road surfaces

If you have been driving for a long time in heavy rain without braking, there may be a delayed response when you first apply the brakes. This may also occur after driving through a car wash or deep water. You must depress the brake pedal more firmly. Maintain a greater distance to the vehicle in front.

While paying attention to the traffic conditions, you should brake the vehicle firmly after driving on a wet road surface or through a car wash. This heats the brake disks so that they dry more quickly, which protects them against corrosion.

Limited braking effect on salt-treated roads:

- a layer of salt on the brake disks or brakepads can increase braking distances considerably, or braking may happen on only one side
- maintain an especially large safe distance to the vehicle in front

To remove the layer of salt:

- apply the brakes from time to time, paying attention to traffic conditions
- carefully depress the brake pedal at the end of a journey and after the start of a new journey

### New brake disks and brakepads

New brakepads and brake disks only reach their optimal braking effect after approximately 100 km.

Until then, compensate for the reduced braking effect by applying greater pressure to the brake pedal. For safety reasons, Mercedes-Benz recommends that you only have brakepads and brake disks which are approved by Mercedes-Benz installed on your vehicle.

Other brake disks or brakepads may compromise the safety of your vehicle.

Always replace all brake disks and brakepads on an axle at the same time. Always fit new brakepads when replacing brake disks.

### Information about driving on wet roads

#### Notes on aquaplaning

Aquaplaning can take place once a certain amount of water has accumulated on the road surface.

Observe the following notes during heavy precipitation or in conditions in which aquaplaning may occur:

- reduce your speed
- avoid tyre ruts
- avoid sudden steering movements
- brake carefully

Also observe the notes on regularly inspecting wheels and tyres (→ page 255).

#### Notes on driving through water on roads

Water which has entered the vehicle can damage the engine, electrics and transmission.

Water can also enter the air intake fitting of the engine and cause engine damage.

Observe the following if you must drive through water:

- The water, when calm, may only reach the lower edge of the vehicle body.
- Drive at walking pace at most; water can otherwise enter the vehicle interior or engine compartment.
- Vehicles travelling in front, or oncoming vehicles, can create waves which may exceed the maximum permissible height of the water

The braking effect of the brakes is reduced after fording. Brake carefully while paying attention to the traffic conditions until braking power has been fully restored.

### Notes on driving in mountainous areas

**Vehicles with diesel engines:** the operating safety of the diesel engine is guaranteed up to a height of 2500 m above sea level. You may exceed this altitude for a short time, e. g. in mountainous terrain. Do not drive continuously at altitudes above 2500 m. Otherwise you may damage the diesel engine. Depending on the vehicle equipment, the operating safety of the diesel engine may also be unimpaired up to a height of 4000 m above sea level. You can obtain information on this at a qualified specialist workshop.

When driving in mountainous areas, note that engine output – and thus start-off capability on gradients – will decrease with increasing altitude. The ECO start/stop function is no longer available when driving at heights of more than 2500 m above sea level. Observe the notes on braking on downhill gradients (→ page 140).

The maximum permissible trailer loads are valid for journeys at heights of up to 1000 m above sea level with gradients up to 12 % (→ page 282).

### ECO start/stop function



#### Operation of the ECO start/stop function

**⚠ WARNING** Risk of accident and injury due to automatic engine starting

If the engine was switched off automatically and you then get out, it started again automatically. The vehicle could pull away.

- ▶ Before leaving the vehicle, always switch off the vehicle and secure the vehicle against rolling away.

Displaying the ECO start/stop function on the instrument cluster:

- : The ECO start/stop function is operational.
  - : Not all vehicle conditions for an engine stop are met.
- i** Depending on the engine, the  symbol first appears during the automatic engine stop or during a journey.

If all vehicle conditions for the automatic engine stop are met, the engine will be switched off automatically:



- **Vehicles with manual transmission:** You decelerate the vehicle to a lower speed, engage neutral **[N]** and then take your foot off the clutch pedal.
- **Vehicles with automatic transmission:** You stop the vehicle in transmission position **[D]** or **[N]**.

The engine will restart automatically in the following cases:

- **Vehicles with manual transmission:** You depress the clutch pedal.
- **Vehicles with automatic transmission:** You release the brake pedal in transmission position **[D]** and with the HOLD function deactivated.
- **Vehicles with automatic transmission:** You select transmission position **[D]** or **[R]**.
- You depress the accelerator pedal.
- The vehicle requires an automatic engine start.

If the engine was switched off by the ECO start/stop function and one of the doors is opened, the engine will automatically start.

### Switching the ECO start/stop function off/on

- ▶ Press the  button on the centre console. When the indicator lamp in the  button lights up, the ECO start/stop function is activated.

### Function of the ECO display

The ECO display summarises your driving characteristics from the start of the journey to its completion and assists you in achieving the most economical driving style. If you interrupt your journey and switch off the vehicle for longer than four hours, the ECO display values will automatically be reset.

You can influence consumption if you:

- Anticipate road and traffic conditions.
- Drive in drive program **[E]** if it is available; otherwise, in drive program **[C]** (→ page 146).
- Follow the gearshift recommendations when changing gear manually.
  - Vehicles with manual transmission (→ page 143)
  - Vehicles with automatic transmission (→ page 146)

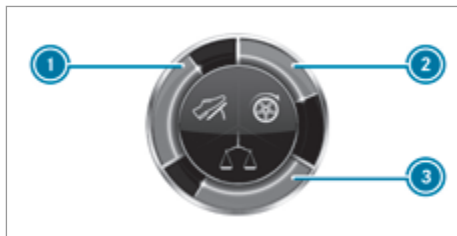

The inner segment lights up green and the outer segment fills up:

- **1** Moderate acceleration
- **2** Gentle deceleration and rolling
- **3** Consistent speed

The inner segment is grey and the outer segment empties:

- **1** Sporty acceleration
- **2** Heavy braking
- **3** Speed fluctuations

You are driving economically if the edge of the ECO display lights up and the three outer segments are completely full at the same time.

The additional range achieved as a result of your driving style in comparison with a driver with a very sporty driving style is shown under **Bonus from start**. The range displayed does not indicate a fixed reduction in consumption.

### Activating ECO display

On-board computer



- ▶ Select **ECO display**.

The instrument cluster display will show the ECO display.

## Manual transmission

### Using the gearshift lever

**!** **NOTE** Damage to the engine and transmission by shifting to a gear that is too low

- ▶ When changing between gears **5** and **6** push the gearshift lever to the right.
- ▶ Do not shift down at high speeds.

**!** **NOTE** Damage to the transmission by shifting to reverse gear **R** while the vehicle is in motion

- ▶ Only shift into reverse gear **R** when the vehicle is stationary.

**!** **NOTE** Damage to the coupling due to improper use

Holding the vehicle on inclines with a slipping coupling can damage it.

- ▶ Do not allow the coupling to slip in order to hold the vehicle on inclines.

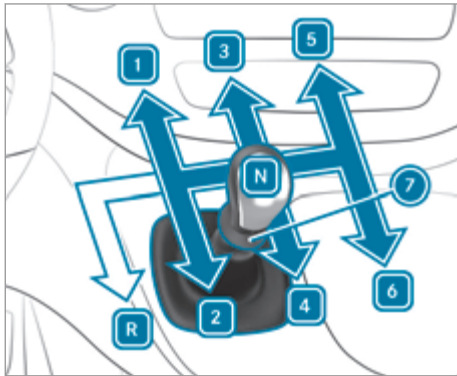

- R** Reverse gear
- 1** - **6** Forward gears
- 7** Reverse gear pull ring
- N** Neutral

- ▶ Fully depress the clutch pedal and shift the gearshift lever to the desired position.

### Gearshift recommendation

The gearshift recommendations assist you in adopting an economical driving style. Depending

on the equipment, these will appear at the top or bottom of the instrument cluster display.

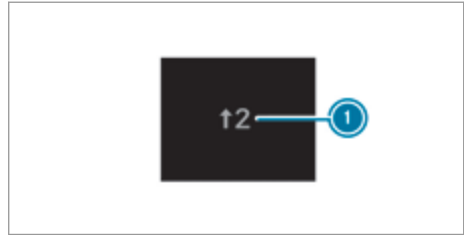

- ▶ If gearshift recommendation **1** appears, shift to the recommended gear.

**i** In vehicles with an ECO start/stop function, a gearshift recommendation to shift to neutral **N** will be displayed as well.

## Automatic transmission

### DIRECT SELECT lever

#### Function of the DIRECT SELECT lever

**!** **WARNING** Risk of accident and injury due to leaving children unattended in the vehicle

If children are left unattended in the vehicle, they could, in particular:

- open doors, thereby endangering other persons or road users.
- get out and be struck by oncoming traffic.
- operate vehicle equipment and become trapped, for example.

In addition, the children could also set the vehicle in motion by, for example:

- releasing the parking brake.
- changing the transmission position.
- starting the vehicle.

- ▶ Never leave children unattended in the vehicle.
- ▶ When leaving the vehicle, always take the key with you and lock the vehicle.
- ▶ Keep the vehicle key out of the reach of children.

**⚠ WARNING** Risk of accident due to incorrect gearshifting

If the engine speed is higher than the idle speed and you engage the transmission position **D** or **R**, the vehicle may accelerate sharply.

- ▶ If you engage the transmission position **D** or **R** when the vehicle is at a standstill, always depress the brake pedal firmly and do not accelerate at the same time.

**Vehicles with 7-speed automatic transmission:**

**⚠ WARNING** Risk of accident due to the vehicle rolling away

When the vehicle is switched off, the automatic transmission shifts into neutral position **N**.

- ▶ Always shift to park position **P** after switching off the vehicle.
- ▶ Secure against rolling away with the parking brake.

**ⓘ NOTE** Transmission damage due to shifting at high engine speed or when the vehicle is rolling

You can damage the automatic transmission if you shift from **D** to **R**, from **R** to **D** or directly to **P** when the engine speed is too high or the vehicle is rolling.

- ▶ Only change the transmission position when the vehicle is stationary.

Depending on the transmission, the automatic transmission switches to transmission position **P** (9-speed automatic transmission) or **N** (7-speed automatic transmission) when switching off the vehicle. The power transmission between the engine and transmission is interrupted in transmission position **N**. In this case, shift the automatic transmission to transmission position **P** before switching off the vehicle when the vehicle is stationary. Observe the messages in the display of the instrument cluster. Apply the parking brake to prevent the vehicle from rolling away.

You use the DIRECT SELECT lever to switch the transmission position. The current transmission position appears in the display of the instrument cluster (→ page 186).

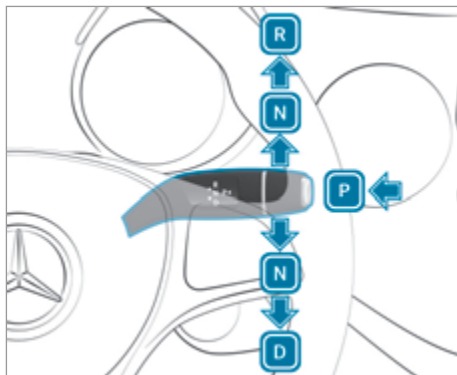

- P** Park position
- R** Reverse gear
- N** Neutral
- D** Drive position

**Engaging reverse gear R**

- ▶ Depress the brake pedal and push the DIRECT SELECT lever upwards past the first point of resistance.

**Selecting neutral N**

**⚠ WARNING** Risk of accident and injury when neutral position is engaged

If you park the vehicle with the transmission in neutral position **N** and the parking brake is not engaged, the vehicle may roll away.

There is a risk of accident and injury!

- ▶ Before parking the vehicle, apply the parking brake.

- ▶ Press the brake pedal and the DIRECT SELECT lever upwards or downwards to the first point of resistance.

- ⓘ When you switch off the vehicle, the 7-speed automatic transmission automatically shifts into neutral **N**.

Subsequently releasing the brake pedal will allow you to move the vehicle freely, e.g. to push it or tow it away.

**If the automatic transmission should also stay in neutral **N** when the vehicle is switched off, proceed as follows:**

- ▶ **7-speed automatic transmission:** Leave the key in the ignition lock.

- ▶ **9-speed automatic transmission:** Start the vehicle.
- ▶ Depress the brake pedal and engage neutral **[N]**.
- ▶ Release the brake pedal.
- ▶ Switch off the vehicle and leave the key in the ignition lock.

### Engaging park position P

- ▶ Press the **[P]** button on the DIRECT SELECT lever when the vehicle is stationary.

Park position **[P]** is engaged automatically when one of the following conditions is met:

- You switch the vehicle off with the transmission in position **[D]** or **[R]** (9-speed automatic transmission).
- You remove the key from the ignition lock.
- You open the driver's door when the vehicle is stationary or moving at a very low speed and with the transmission in position **[D]** or **[R]**.

### Engaging drive position D

- ▶ Depress the brake pedal and push the DIRECT SELECT lever downwards past the first point of resistance.

The automatic transmission shifts through the individual gears automatically when it is in transmission position **[D]**. This is determined by the following factors:

- The drive program selected (→ page 146)
- Shift range is limited (→ page 145)
- Position of the accelerator pedal
- Driving speed

### Rocking free

This function is only available for vehicles with 7-speed automatic transmission.

At speeds of up to 9 km/h you can switch back and forth between transmission positions **[D]** and **[R]** without applying the brakes. This helps when rocking the vehicle free out of snow or slush.

- ▶ Push the DIRECT SELECT lever alternately upwards and downwards past the first point of resistance.

## Restricting the shift range

### Requirements:

- Transmission position **[D]** is engaged (→ page 145).
- Drive program **[C]**, **[E]** or **[S]** is selected (→ page 146).



- ▶ **To restrict the shift range:** Briefly pull the steering wheel gearshift paddle **①**.

The automatic transmission shifts to the next lower gear, depending on the gear currently engaged. The shift range is also restricted.

The selected shift range is shown in the instrument cluster display. The automatic transmission shifts only as far as the selected gear.

- ▶ Pull and hold the steering wheel gearshift paddle **①**.

The automatic transmission will change to a shift range which allows easy acceleration and deceleration. To do this, the automatic transmission shifts down one or more gears and restricts the shift range.

The selected shift range is shown in the instrument cluster display. The automatic transmission shifts only as far as the selected gear.

- ① The automatic transmission does not shift down if you pull the steering wheel gearshift paddle **①** whilst travelling at too high a speed.

If the maximum engine speed for the restricted shift range is reached and you continue to depress the accelerator pedal, the automatic transmission will shift up automatically. This protects against engine overrev.

- ▶ **To de-restrict the shift range:** Briefly pull the steering wheel gearshift paddle **②**.

The automatic transmission shifts to the next gear up, depending on the gear currently engaged. This de-restricts the shift range at the same time.

The selected shift range is shown in the instrument cluster display. The automatic transmission shifts only as far as the selected gear.

- **To de-restrict the shift range:** Pull and hold the steering wheel gearshift paddle ②.

or

- engage transmission position **D** again (→ page 145).

The automatic transmission shifts up one or more gears depending on the gear currently engaged. Simultaneously, the shift range restriction is deactivated and the transmission position display appears in the instrument cluster display **D**.

Recommended shift ranges for the following driving conditions:

- ③ Use the engine's braking effect.
- ② Use the engine's braking effect on downhill gradients and when driving on steep roads, in mountainous areas as well as under arduous operating conditions.
- ① Use the engine's braking effect on extremely steep downhill gradients and on long downhill stretches.

## Drive programs

### Function of the DYNAMIC SELECT switch

- ① Depending on the engine line-up and equipment, the vehicle has different drive programs.

Use the DYNAMIC SELECT switch to switch between the following drive programs.

The drive program selected appears in the instrument cluster display next to the transmission position display. After starting the vehicle, the automatic transmission switches automatically to drive program **C**.

#### **M** Manual

- Permanent manual gearshifting

#### **S** Sports

- Stable but sporty handling
- Can lead to higher fuel consumption

#### **C** Comfort



- Comfortable and economical driving
- Balance between traction and stability
- Improved driving stability, e.g., on slippery road surfaces

#### **E** Eco

- Particularly economical driving
- Reduced engine torque
- In kickdown, automatic change to **C**
- Improved driving stability, e.g., on slippery road surfaces

#### (Lift) vehicles with AIRMATIC:

- Driving up to a speed of approx. 30 km/h with increased vehicle level for greater ground clearance
- Comfortable and economical driving
- From speeds of approx. 100 km/h changes automatically to **C**

- ① For the drive program **Lift**, the instrument cluster display shows the  symbol next to the transmission position display. The display shows the symbol .

### Selecting the drive program

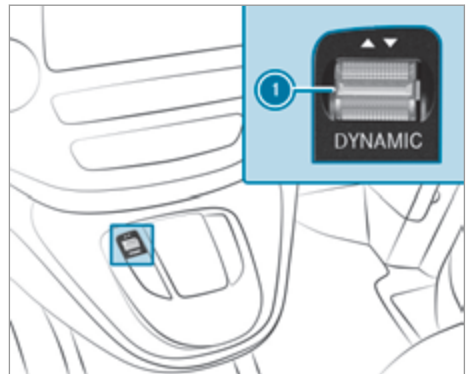

- Press the DYNAMIC SELECT switch ① forwards or backwards. The selected drive program appears in the instrument cluster display.

### Manual shifting



You can change gear manually with the steering wheel gearshift paddles when the automatic transmission is in position **[D]**. If permissible, the automatic transmission shifts to a higher or lower gear depending on the steering wheel gearshift paddle that has been pulled.

To shift the automatic transmission manually, you have the following options:

- Temporary setting in all drive programs except **[M]** with simultaneous limitation of the shift range (→ page 145)
- Permanent setting in drive program **[M]**

### Permanent setting:

▶ Select the drive program **[M]** (→ page 146). The instrument cluster display indicates the transmission position and the current gear e.g. **M1**.

ⓘ Permanent manual shifting is deactivated automatically when you switch from drive program **[M]** to another drive program. The **[D]** transmission position is shown again in the instrument cluster display.

▶ **To shift up:** Pull steering wheel gearshift paddle **②**.

If the engine speed is sufficient, the automatic transmission shifts up to the next gear.

If the maximum engine speed is reached in the currently engaged gear and you continue to accelerate, the automatic transmission will not shift up automatically. Always make sure that the engine speed does not reach the red area of the rev counter. Observe the gearshift recommendation in the display of the instrument cluster. When the engine reaches its maximum speed, the fuel supply is cut to prevent the engine from overrevving.

▶ **To shift down:** Pull steering wheel gearshift paddle **①**.

Provided that the engine will not exceed its maximum speed when shifting down, the automatic transmission shifts to the next lower gear.

If you pull and hold the steering wheel gearshift paddle **①**, the transmission shifts to the lowest possible gear.

ⓘ When coasting, the automatic transmission shifts down automatically.

### Gearshift recommendation

The gearshift recommendations assist you in adopting an economical driving style. It will appear

in the transmission position and drive program display.

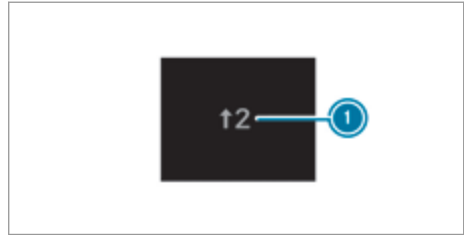

▶ If gearshift recommendation **①** appears, shift to the recommended gear.

### Using kickdown

▶ **For maximum acceleration:** depress the accelerator pedal beyond the pressure point.

ⓘ The drive program switches automatically from **[E]** to **[C]** (vehicles with drive program **[E]**).

### All-wheel drive

#### Notes on the 4MATIC

4MATIC ensures permanent drive for all four wheels, and together with ESP® it improves the vehicle's traction.

ⓘ In wintry road conditions, the maximum effect of 4MATIC can be achieved only if you use winter tyres (M+S tyres), with snow chains if necessary.

Use DSR (Downhill Speed Regulation) when driving downhill off-road (→ page 161).

If you fail to adapt your driving style, 4MATIC can neither reduce the risk of an accident nor override the laws of physics. 4MATIC cannot take account of road, weather and traffic conditions. 4MATIC is only an aid. You are responsible especially for maintaining a safe distance from the vehicle in front, for vehicle speed, for braking in good time and for staying in lane.



### AIRMATIC



#### Function of AIRMATIC

AIRMATIC is an air suspension system with an all-round level control system, which also ensures the best possible suspension and constant ground clearance, even with a laden vehicle. When you

drive at speed, the vehicle is lowered automatically to improve driving safety and to reduce fuel consumption. There is also the option of raising the vehicle level while driving slowly, e.g. for driving off public roads. The AIRMATIC settings are dependent on the drive program selection.

AIRMATIC consists of the following functions and components:

- all-round air suspension
- speed-dependent lowering to reduce fuel consumption
- high level for greater ground clearance when driving slowly, for example off public roads, set with the **Lift**  /  drive program
- DYNAMIC SELECT switch

**i** For the **Lift** drive program, the instrument cluster shows the  symbol next to the transmission position display. The media display shows the  menu.



### Vehicle levels per drive program

Drive programs **C** and **M**:

- the vehicle is set to normal level
- at speeds above approx. 110 km/h, the vehicle is lowered
- at speeds below approx. 75 km/h, the vehicle is raised again

Drive program **S**:

- the vehicle is set to low level
- at higher speeds, the vehicle level does not continue to lower

Drive program  / :

- the vehicle is set to high level
- at speeds above approx. 30 km/h, the vehicle level lowers to the normal level
- at speeds below approx. 10 km/h, the vehicle is raised again
- at speeds above approx. 100 km/h, the vehicle switches to drive program **C**

**i** If the vehicle is raised in the **Lift** drive program or lowered when changing from the **Lift** drive program to another drive program, occasional creaking noises may occur at the brake.

**i** **Operation with a trailer or bicycle rack:** if the electrical connection has been correctly established, the vehicle remains on normal level regardless of speed.

### System limits

If overheating protection has been activated due to several level changes in a short period of time, AIRMATIC will not function or its availability will be limited. The **Compressor is cooling** message is shown in the multifunction display.

After the cooling phase, AIRMATIC is again available without restrictions.

## Refuelling

### Refuelling the vehicle

**⚠ WARNING** Risk of fire or explosion from fuel

Fuels are highly flammable.

- ▶ Fire, naked flames, smoking and creating sparks must be avoided.
- ▶ Before refuelling, switch off the vehicle and, if fitted, the stationary heater and keep switched off during filling.

**⚠ WARNING** Risk of injury from fuels

Fuels are poisonous and hazardous to your health.

- ▶ Do not swallow fuel or let it come into contact with skin, eyes or clothing.
- ▶ Do not inhale fuel vapour.
- ▶ Keep children away from fuel.
- ▶ Keep doors and windows closed during the refuelling process.

If you or other people come into contact with fuel, observe the following:

- ▶ Immediately rinse fuel off your skin with soap and water.
- ▶ If fuel comes into contact with your eyes, immediately rinse them thoroughly with clean water. Seek medical attention immediately.
- ▶ If you swallow fuel, seek medical attention immediately. Do not induce vomiting.
- ▶ Change immediately out of clothing that has come into contact with fuel.

**⚠ WARNING** Risk of fire and explosion due to electrostatic charge

Electrostatic charge can ignite fuel vapour.

- ▶ Before you open the fuel filler cap or take hold of the pump nozzle, touch the metallic vehicle body.
- ▶ To avoid creating another electrostatic charge, do not get into the vehicle again during the refuelling process.

**⚠ WARNING** Risk of fire from fuel mixture

Vehicles with a diesel engine:

If you mix diesel fuel with petrol, the flash point of the fuel mixture is lower than that of pure diesel fuel.

While the vehicle is running, component parts in the exhaust system may overheat without warning.

- ▶ Never refuel using petrol.
- ▶ Never mix petrol with diesel fuel.

**! NOTE** Do not use diesel to refuel vehicles with a petrol engine

If you have accidentally refuelled with the wrong fuel:

- Do not switch on the vehicle. Otherwise fuel can enter the engine.
- Even small amounts of the wrong fuel could result in damage to the fuel system and the engine. The repair costs are high.

- ▶ Consult a qualified specialist workshop.
- ▶ Have the fuel tank and fuel lines drained completely.

**! NOTE** Do not use petrol to refuel vehicles with a diesel engine

If you have accidentally refuelled with the wrong fuel:

- Do not switch on the vehicle. Otherwise, fuel can enter the fuel system.
- Even small amounts of the wrong fuel could result in damage to the fuel system and the engine. The repair costs are high.

- ▶ Consult a qualified specialist workshop.
- ▶ Have the fuel tank and fuel lines drained completely.

**! NOTE** Damage to the fuel system caused by overfilled fuel tanks

- ▶ Only fill the fuel tank until the pump nozzle switches off.

**Requirements:**

- The vehicle is unlocked and switched off.
  - The auxiliary heating is switched off.
  - The front left-hand door is open.
- i** Do not get back into the vehicle during the refuelling process. Otherwise, electrostatic charge could build up again.

Observe the notes on operating fluids (→ page 274).

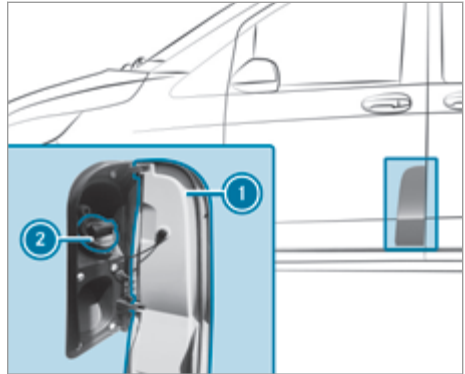

- ▶ Open fuel filler flap ①.
- ▶ Turn fuel filler cap ② anti-clockwise and remove it.
- ▶ Close all vehicle doors to prevent fuel vapours from entering the vehicle interior.
- ▶ Completely slide the filler neck of the pump nozzle into the tank, hook in place and refuel.
- ▶ Fill the fuel tank only until the pump nozzle switches off.
- ▶ Replace fuel filler cap ② and turn it clockwise. You will hear a click when the fuel filler cap is closed fully.
- ▶ Open the front left-hand door.
- ▶ Close fuel filler flap ①.

**i** **Vehicles with a diesel engine and incorrect fuelling protector against refuelling with petrol:** the filler neck is designed for refuelling at diesel filling pumps for passenger vehicles.

- i** **Vehicles with a diesel engine without an incorrect fuelling protector:** refuelling preferred at diesel filling pumps for passenger vehicles. However, you can also refuel at a diesel filling pump for lorries.
- i** If the fuel tank has been run completely dry, top up with at least 5 l of fuel. Switch on the vehicle three to four times before starting the vehicle.
- i** Vehicles that can use a mixture of fuels can be recognised by the sticker "Ethanol up to E85!" on the fuel filler flap.

## AdBlue®

### Notes on AdBlue®

AdBlue® is a water-soluble fluid for the exhaust gas aftertreatment of diesel engines. In order for the exhaust gas aftertreatment to function properly, only use AdBlue® in accordance with ISO 22241.

AdBlue® has the following properties:

- non-toxic
- colourless and odourless
- non-flammable

If you open the AdBlue® tank, small amounts of ammonia vapour may be released. Fill the AdBlue® tank only in well-ventilated areas.

Do not let AdBlue® come into contact with skin, eyes or clothes. Keep AdBlue® away from children.

Do not ingest AdBlue®. If AdBlue® is swallowed, immediately rinse your mouth out thoroughly. Drink plenty of water. Seek medical attention at once.

Observe the notes on the operating fluid AdBlue® (→ page 277).

AdBlue® availability:

- AdBlue® can be topped up at a qualified specialist workshop, e.g. a Mercedes-Benz Service Centre.
  - AdBlue® is available at numerous filling stations via AdBlue® filling pumps.
  - Alternatively, AdBlue® is available at qualified specialist workshops, e.g. a Mercedes-Benz Service Centre, and at numerous filling stations as an AdBlue® refill canister or AdBlue® refill bottle.
- i** Ensure the connection between the refill container and vehicle filler neck does not drip.

### Calling up the AdBlue® range and AdBlue® fill level display

On-board computer:

↳ Service ▶▶ AdBlue

AdBlue® freezes at a temperature of approximately -11 °C. The vehicle is equipped with an AdBlue® preheating system at the factory. This means that winter operation is also ensured for temperatures below -11 °C. If you top up AdBlue® at temperatures below -11 °C, the AdBlue® level in the instrument cluster may not be displayed correctly. If the AdBlue® is frozen, drive for at least 20 minutes and then park the vehicle for a minimum of 30 seconds, so that the level is correctly displayed. In extreme winter conditions, the time needed to detect the amount topped up may be considerably longer. Park the vehicle in a warm garage to speed up this process.

- ▶ Call up the menu.  
The instrument cluster display will show the AdBlue® level.

### Topping up AdBlue®

**!** **NOTE** Engine damage due to AdBlue® being in the fuel

- ▶ AdBlue® must not be used to fill the fuel tank.
- ▶ Only use AdBlue® to fill the AdBlue® tank.
- ▶ Do not overfill the AdBlue® tank.

**!** **NOTE** Contamination of the vehicle interior due to AdBlue® leakage

- ▶ After topping up, carefully close the AdBlue® refill container.
- ▶ Avoid carrying AdBlue® refill containers permanently in the vehicle.

**!** **NOTE** Overfilling the AdBlue® tank due to the vehicle standing at an angle

The AdBlue® tank can only be filled as intended when the vehicle is parked on a level surface. This way, variations in the filling amount are avoided.

When filling the reservoir when the vehicle is standing at an angle, there is a risk of overfilling. This may damage exhaust gas aftertreatment components.

- ▶ Park the vehicle on a level surface to fill the AdBlue® tank.

### Requirements:

- The auxiliary heating is switched off.
- The vehicle is switched off.
- The front left-hand door is open.

The following messages that appear in succession in the instrument cluster display indicate that you need to refill the AdBlue® tank:

- **Refill AdBlue** See [Owner's Manual](#)  
The AdBlue® tank has dropped to the reserve level.
- **Refill AdBlue Emer. oper. in XXX km** See [Owner's Manual](#)

The low AdBlue® level will result in limited performance after the remaining distance displayed has been driven. Top up AdBlue® as quickly as possible.

- **Emergency operation: 20 km/h No start in XXX km** See [Operating Instructions](#)

The vehicle speed is limited to approximately 20 km/h. You will only be able to drive the vehicle the distance shown. Subsequently, it will no longer be possible to start the vehicle.

- **Refill AdBlue Engine start not possible**

The vehicle can no longer be started.

You can also have the AdBlue® fill level and the AdBlue® range displayed (→ page 150).

### Opening the AdBlue® filler cap

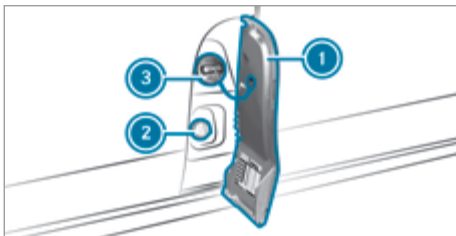

- ▶ Open the front door on the left-hand side and fold out filler flap ①.
- ▶ Close all vehicle doors to prevent ammonia vapours from entering the vehicle interior.
- ▶ Turn blue AdBlue® filler cap ② anti-clockwise and remove it.  
Fuel filler cap ③ for the fuel remains closed.

### Refuelling with a refill canister

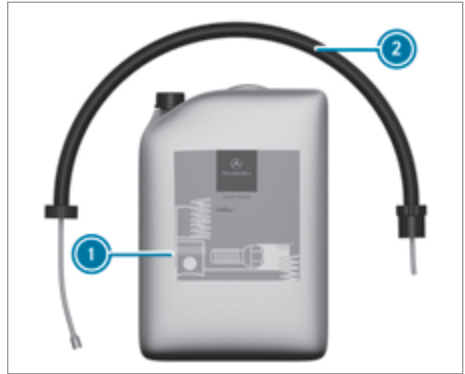

#### Example

- ▶ Unscrew the cap on AdBlue® refill canister ①.
- ▶ Screw disposable hose ② onto the opening of AdBlue® refill canister ① until hand-tight.
- ▶ Screw disposable hose ② onto the filler neck of the vehicle until hand-tight.
- ▶ Lift up and tip AdBlue® refill canister ①. The filling process stops when the AdBlue® tank is completely full.  
AdBlue® refill canister ① can be removed when it has been only partially emptied.

ⓘ Avoid storing AdBlue® containers permanently in the vehicle.

- ▶ Unscrew disposable hose ② in reverse order from AdBlue® refill canister ① and the filler neck of the vehicle.

### Closing the AdBlue® filler cap

- ▶ After filling the AdBlue® tank, place the AdBlue® filler cap on the filler neck and tighten it clockwise.
- ▶ Turn the AdBlue® filler cap until the lettering is legible and horizontal. The filler neck is only locked correctly when this is the case.
- ▶ Open the front left-hand door first, and then close the filler flap.
- ▶ Switch on the vehicle.  
The **Refill AdBlue** See [Owner's Manual](#) message in the instrument cluster display must go out after approximately 20 seconds. If the message continues to be displayed, you must add more AdBlue®.

## Parking

### Parking the vehicle

- ⚠ WARNING** Risk of fire caused by hot exhaust system parts

Flammable materials such as leaves, grass or twigs may ignite.

- ▶ Park the vehicle so that no flammable material can come into contact with hot vehicle components.
- ▶ In particular, do not park on dry grass-land or harvested grain fields.

- ⚠ WARNING** Risk of accident and injury due to leaving children unattended in the vehicle

If children are left unattended in the vehicle, they could, in particular:

- open doors, thereby endangering other persons or road users.
- get out and be struck by oncoming traffic.
- operate vehicle equipment and become trapped, for example.

In addition, the children could also set the vehicle in motion by, for example:

- releasing the parking brake.
  - changing the transmission position.
  - starting the vehicle.
- ▶ Never leave children unattended in the vehicle.
  - ▶ When leaving the vehicle, always take the key with you and lock the vehicle.
  - ▶ Keep the vehicle key out of the reach of children.

- ! NOTE** Damage to the vehicle or the drivetrain due to rolling away

- ▶ Always park your vehicle safely and according to legal requirements.
- ▶ Always properly secure the vehicle against rolling away.

- ! NOTE** Transmission damage due to rollers in neutral position

If the vehicle is switched off and rolling in neutral position (e.g. when towing), this can dam-

age the drivetrain and lead to transmission damage.

- ▶ Only allow the vehicle to roll in neutral position for a short time.

Depending on the transmission, the automatic transmission switches to transmission position **P** (9-speed automatic transmission) or **N** (7-speed automatic transmission) when switching off the vehicle. The power transmission between the engine and transmission is interrupted in transmission position **N**. In this case, shift the automatic transmission to transmission position **P** before switching off the vehicle when the vehicle is stationary. Observe the messages in the display of the instrument cluster. Apply the parking brake to prevent the vehicle from rolling away.

Observe the following points to ensure that the vehicle is properly secured against rolling away unintentionally.

- ▶ Always apply the parking brake.
- ▶ **On uphill or downhill inclines:** Turn the front wheels towards the kerb.
- ▶ **Vehicles with manual transmission:** Engage first or reverse gear.
- ▶ **Vehicles with automatic transmission:** Engage transmission position **P**.
- ▶ Turn the key to position **0**.

### Electric parking brake

#### Information on the electric parking brake

- ⚠ WARNING** Risk of accident and injury due to leaving children unattended in the vehicle

If children are left unattended in the vehicle, they could, in particular:

- open doors, thereby endangering other persons or road users.
- get out and be struck by oncoming traffic.
- operate vehicle equipment and become trapped, for example.

In addition, the children could also set the vehicle in motion by, for example:

- releasing the parking brake.
- changing the transmission position.
- starting the vehicle.

- ▶ Never leave children unattended in the vehicle.
- ▶ When leaving the vehicle, always take the key with you and lock the vehicle.
- ▶ Keep the vehicle key out of the reach of children.



Observe the note on transporting animals in the vehicle (→ page 51).

For the automatic functions to work correctly, the driver must be seated in the correct seat position (→ page 72).

- ① The electric parking brake is only actually applied when the red  indicator lamp lights up continuously.

### Function of the electric parking brake (applying automatically)

When you remove the key from the ignition lock when the vehicle is stationary, the parking brake is applied automatically.

The red  indicator lamp in the instrument cluster lights up. The electric parking brake is only actually applied when the red  indicator lamp lights up continuously.

### Function of the electric parking brake (releasing automatically)

#### Vehicles with automatic transmission:

The electric parking brake of your vehicle is released when all of the following conditions are fulfilled:

- the co-driver seat is occupied
- the seat belt tongue of the seat belt is inserted into the driver's seat belt buckle
- the vehicle has been started
- you shift the transmission to position **D** or **R**

#### Vehicles with manual transmission:

The electric parking brake of your vehicle is released when all of the following conditions are fulfilled:



- the co-driver seat is occupied
- the seat belt tongue of the seat belt is inserted into the driver's seat belt buckle
- the vehicle has been started
- a gear is engaged
- you release the clutch pedal and depress the accelerator pedal at the same time

- ① The holding force of the parking brake is already reduced when the pulling-away gear is engaged. Therefore also depress the brake pedal when engaging the gear. Only then is your vehicle secured against rolling away.

### Applying/releasing the electric parking brake manually

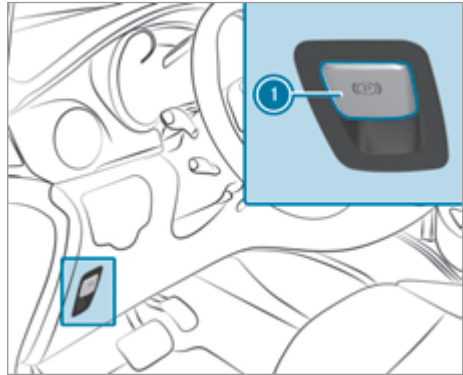
#### Applying the electric parking brake



- ▶ Turn the key in the ignition lock to position **1** or **2**.  
If you turn the key to position **0** in the ignition lock, you can only apply the parking brake within the next five minutes.
- ▶ Press switch **1**.  
When the electric parking brake is applied, the red  indicator lamp lights up in the instrument cluster. The electric parking brake is only actually applied when the red  indicator lamp lights up continuously.

#### Releasing the electric parking brake

- ▶ Turn the key in the ignition lock to position **1** or **2**.  
If you turn the key from position **1** to position **0** in the ignition lock, you can release the parking brake once.
- ▶ Depress the brake pedal.
- ▶ Pull switch **1**.  
The red  indicator lamp in the instrument cluster goes out.

- i** If you apply and release the parking brake frequently within a short period, it may not be possible to release the parking brake again in some cases. To protect it from damage, the parking brake is temporarily locked and cannot be released – repeat lock. The parking brake is operational again after approximately 20 seconds.

### Emergency braking

If, in exceptional cases, the service brake fails, you can use the parking brake to perform emergency braking. The braking distance is then considerably greater.

- ▶ While driving, press switch **1** of the electric parking brake.  
The vehicle is braked as long as you keep switch **1** of the electric parking brake depressed.  
The vehicle's brake lights light up.  
The longer electric parking brake switch **1** is depressed, the greater the braking force.

During the braking procedure, you will receive the following feedback from the vehicle:

- A warning tone sounds.
- The **Release parking brake** message appears in the instrument cluster.
- The red  indicator lamp flashes in the instrument cluster.

When the vehicle has been braked to a standstill, the electric parking brake is applied.

### Parking up the vehicle

#### Parking up the vehicle for longer than four weeks

- ▶ Connect the starter battery to a trickle charger via a jump-start connection (→ page 243).

or

- ▶ Disconnect all batteries (→ page 245).

#### Parking up the vehicle for longer than six weeks

- ▶ Contact a qualified specialist workshop and seek advice.  
The vehicle can otherwise suffer damage as a result of lack of use.

## Driving and driving safety systems

### Notes on driving systems and your responsibility

Your vehicle is equipped with driving systems which assist you in driving, parking and manoeuvring the vehicle. The driving systems are only aids. They are not a substitute for you paying attention to your surroundings and do not relieve you of your responsibility pertaining to road traffic law. The driver is always responsible for maintaining a safe distance to the vehicle in front, for vehicle speed, for braking in good time and for staying in lane. Always pay attention to the traffic and intervene if necessary. Be aware of the limitations regarding the safe use of these systems.

Driving systems can neither reduce the risk of accident if you fail to adapt your driving style nor override the laws of physics. They cannot always take into account road, weather or traffic conditions.

### Information on vehicle sensors and cameras

Some driving and driving safety systems use cameras and radar or ultrasonic sensors to monitor the area in front of, behind or next to the vehicle.

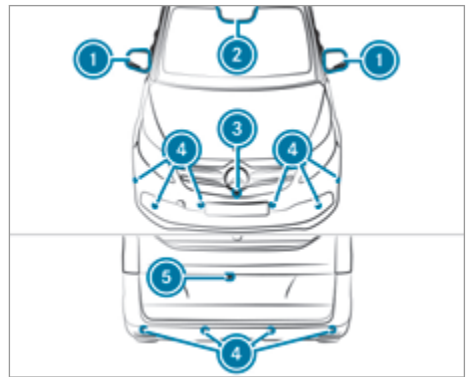

- 1** Cameras in the outside mirrors
- 2** Multifunction camera
- 3** Front camera
- 4** Ultrasonic sensors
- 5** Reversing camera

- i** Depending on the vehicle's equipment, the radar sensors are integrated on the side of the rear bumpers and/or behind the Mercedes star in the radiator grille.

**⚠ WARNING** Risk of accident due to restricted detection performance of vehicle sensors and cameras

If the area around vehicle sensors or cameras is covered, damaged or dirty, certain driving and safety systems cannot function correctly. There is a risk of an accident.

- ▶ Keep the area around vehicle sensors or cameras clear of any obstructions and clean.
- ▶ Have damage to the bumper, radiator grille or stone chipping in the area of the front and rear windows repaired at a qualified specialist workshop.

Keep the areas of the cameras and sensors free of dirt, ice and slush (→ page 235). The sensors and cameras must not be covered and the detection ranges around them must be kept free. Do not attach additional license plate brackets, advertisements, stickers, foils or foils to protect against stone chippings in the detection range of the sensors and cameras. Make sure that there are no overhanging loads protruding into the detection range.

In the event of damage, or following a severe impact, have the function of the sensors checked at a qualified specialist workshop. Have damage or stone chipping in the area of the cameras repaired at a qualified specialist workshop.

## Overview of driving systems and driving safety systems

In this section, you will find information about the following driving systems and driving safety systems:

- ABS (**A**nti-**l**ock **B**raking **S**ystem) (→ page 155)
- BAS (**B**rake **A**ssist **S**ystem) (→ page 155)
- ESP® (**E**lectronic **S**tability **P**rogram) (→ page 155)
- EBD (**E**lectronic **B**rake**f**orce **D**istribution) (→ page 157)
- Active Brake Assist (→ page 157)
- Adaptive brake lights (→ page 159)
- Cruise control (→ page 159) and limiter (→ page 159)
- Active Distance Assist DISTRONIC (→ page 163)
- Hill start assist (→ page 166)

- HOLD function (→ page 166)
- Parking Assist PARKTRONIC (→ page 167)
- Reversing camera (→ page 168)
- 360° Camera (→ page 170)
- Active Parking Assist (→ page 172)
- ATTENTION ASSIST (→ page 175)
- Traffic Sign Assist (→ page 176)
- Blind Spot Assist (→ page 177)
- Lane Keeping Assist (→ page 178)

## Function of ABS (Anti-lock Braking System)

ABS controls the brake pressure in critical situations:

- During braking, for instance, at maximum full-stop braking or if there is insufficient tyre traction, the wheels are prevented from locking.
- The steerability of the vehicle in terms of physical possibilities is ensured when braking.

If ABS intervenes, you will feel pulsations in the brake pedal. The pulsating brake pedal may be an indication of hazardous road conditions and functions as a reminder to take extra care while driving.

## Function of BAS (Brake Assist System)

BAS supports you with additional braking force in an emergency braking situation.

If you depress the brake pedal quickly, BAS is activated:

- BAS automatically boosts the braking force of the brakes
- BAS can shorten the braking distance
- ABS prevents the wheels from locking

When you release the brake pedal, the brakes function as usual again. BAS is deactivated.

## Function of ESP® (Electronic Stability Program)

**⚠ WARNING** Risk of skidding if ESP® is deactivated

If you deactivate ESP®, ESP® cannot carry out vehicle stabilisation.

- ▶ ESP® should only be deactivated in the following situations.

ESP® can, within physical limits, monitor and improve driving stability and traction in the following situations:

- when driving and pulling away on wet or slippery road surfaces
- when braking

If the vehicle is deviating from the direction desired by the driver, ESP® can stabilise the vehicle by performing the following actions:

- one or more wheels are braked
- the engine output is adapted according to the situation

**i** Only use wheels with the recommended tyre sizes. Only then will ESP® function properly.

If the  warning lamp flashes in the instrument cluster, one or more wheels have reached their traction limit:

- adapt your driving style to suit the prevailing road and weather conditions
- do not deactivate ESP® under any circumstances
- only depress the accelerator pedal as far as is necessary when pulling away

Deactivate ESP® in the following situations to improve traction:

- When using snow chains.
- In deep snow.
- On sand or gravel.

**i** Spinning the wheels results in a cutting action, which enhances traction.

If the  warning lamp lights up continuously, ESP® is not available due to a malfunction.

Observe the information on warning lamps and display messages (→ page 307).

When ESP® is deactivated, the  warning lamp in the instrument cluster lights up continuously.

Observe the following points when ESP® is deactivated:

- vehicle stabilisation is delayed and is significantly reduced in the lower speed range
- the drive wheels may start to spin
- traction control is still active

**i** If ESP® is deactivated, ESP® will still support you when braking.

### Deactivating or activating ESP® using the button

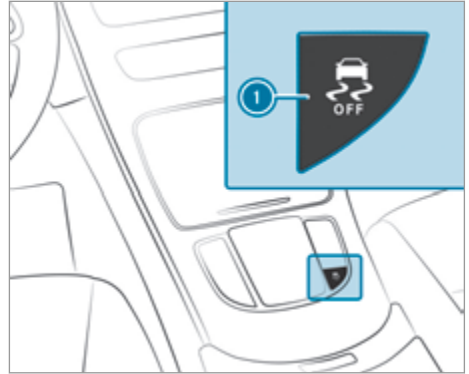

▶ Press button **1**.

The  warning lamp in the instrument cluster goes on when ESP® is deactivated.



**i** Observe the information on warning lamps and display messages (→ page 307).

### Deactivating or activating ESP® using the on-board computer

On-board computer:

→  **Settings** **» Assistance** **» ESP**

Adjusting settings using the on-board computer is only available on vehicles without the  button on the centre console.

▶ **To deactivate/activate:** press the  button. If ESP® is deactivated, the  warning lamp in the instrument cluster lights up.

**i** Observe the information on warning lamps and display messages (→ page 307).

### Function of ESP® Crosswind Assist

ESP® Crosswind Assist detects sudden gusts of side wind and helps the driver to keep the vehicle in the lane:

- ESP® Crosswind Assist is active at vehicle speeds above approx. 80 km/h when driving straight ahead or cornering slightly.
- The vehicle is stabilised by means of individual brake application on one side. The instrument cluster displays a message with the traffic sign for a strong crosswind.

ESP® Crosswind Assist does not react under the following conditions:

- The vehicle is subjected to severe jolts and vibrations, e.g. as a result of uneven surfaces or potholes.
- The vehicle loses traction, e.g. on snow or ice or when aquaplaning.

### Function of ESP® trailer stabilisation

**⚠ WARNING** Risk of accident in poor road and weather conditions

In poor road and weather conditions, the trailer stabilisation cannot prevent lurching of the vehicle/trailer combination. Trailers with a high centre of gravity may tip over before ESP® detects this.

- ▶ Always adapt your driving style to suit the current road and weather conditions.

When you are driving with a trailer, ESP® trailer stabilisation can stabilise your vehicle if it begins to swerve from side to side:

- If the system detects the trailer, ESP® trailer stabilisation is active at speeds above approximately 65 km/h.
- Minor swerving is reduced by a targeted, individual brake application on one side.
- In the event of severe swerving, the engine output is also reduced and all wheels are braked.

### Function of EBD (Electronic Brakeforce Distribution)

EBD has the following characteristics:

- monitoring and controlling the braking force on the rear wheels
- improving driving stabilisation when braking, especially on bends

### Function of Active Brake Assist

Active Brake Assist consists of the following functions:

- Distance warning function
- Autonomous braking function
- Situation-dependent brake force boosting

Active Brake Assist can help you to minimise the risk of a collision with vehicles, cyclists or pedestrians, or reduce the effects of such a collision.

If Active Brake Assist has detected a risk of collision, a warning tone sounds and the  warning lamp lights up in the instrument cluster.

If you do not react to the warning, autonomous braking can be initiated in critical situations. In especially critical situations, Active Brake Assist can initiate autonomous braking directly. In this case, the warning lamp and warning tone are activated simultaneously with the braking application.

If you apply the brake yourself in a situation detected as critical by Active Brake Assist, or apply the brake during autonomous braking, situation-dependent brake force boosting occurs. The brake pressure increases up to maximum full-stop braking if necessary.

If autonomous braking or a situation-dependent braking boosting effect has occurred, the  warning lamp flashes briefly and then goes out.

**Vehicles with PRE-SAFE®:** if the autonomous braking function or the situation-dependent brake force boosting is triggered, additional preventive measures for occupant protection (PRE-SAFE) may also be initiated (→ page 39).

**⚠ WARNING** Risk of an accident caused by limited detection performance of Active Brake Assist

Active Brake Assist cannot always clearly identify objects and complex traffic situations.

In such cases, Active Brake Assist might:

- Give a warning or brake without reason
- Not give a warning or not brake

Active Brake Assist is only an aid. The driver is responsible for maintaining a sufficiently safe distance to the vehicle in front, vehicle speed and for braking in good time.



- ▶ Always pay careful attention to the traffic situation; do not rely on Active Brake Assist alone.
- ▶ Be prepared to brake or swerve if necessary.

Observe the system limitations of Active Brake Assist. Due to the nature of the system, complex but non-critical driving conditions may also cause Active Brake Assist to intervene during braking.

The individual subfunctions are available in the following speed ranges:

#### Distance warning function

The distance warning function warns you in the following situations:

- From approximately 30 km/h, if over several seconds the distance maintained to the vehicle travelling in front is insufficient for the driven speed, the  warning lamp lights up in the instrument cluster.
- From approximately 7 km/h, if your vehicle is critically close to a vehicle or pedestrian, an intermittent warning tone sounds and the  warning lamp lights up in the instrument cluster.

Brake immediately or take evasive action, provided it is safe to do so and the traffic situation allows this.

The distance warning function can aid you in the following situations with an intermittent warning tone and a warning lamp:

- **Vehicles travelling in front:** up to approximately 250 km/h
- **Stationary vehicles:** up to approximately 80 km/h
- **Crossing vehicles:** no reaction
- **Moving pedestrians/cyclists ahead:** up to approximately 80 km/h
- **Crossing cyclists:** up to approximately 60 km/h
- **Stationary pedestrians:** no reaction

#### Autonomous braking function

The autonomous braking function may intervene at speeds starting from approximately 7 km/h in the following situations:

- **Vehicles travelling in front:** up to approximately 200 km/h
- **Stationary vehicles:** up to approximately 50 km/h
- **Crossing vehicles:** no reaction
- **Cyclists ahead:** up to approximately 80 km/h
- **Moving pedestrians/crossing cyclists:** up to approximately 60 km/h
- **Stationary pedestrians:** no reaction

#### Situation-dependent brake force boosting

Situation-dependent brake force boosting may intervene at speeds starting from approximately 7 km/h in the following situations:

- **Vehicles travelling in front:** up to approximately 250 km/h
- **Stationary vehicles:** up to approximately 80 km/h
- **Crossing vehicles:** no reaction
- **Cyclists ahead:** up to approximately 80 km/h
- **Moving pedestrians/crossing cyclists:** up to approximately 60 km/h
- **Stationary pedestrians:** no reaction

#### Cancelling a brake application of Active Brake Assist

You can cancel a brake application of Active Brake Assist at any time by:

- Fully depressing the accelerator pedal or with kickdown.
- Releasing the brake pedal.

Active Brake Assist may cancel the brake application when one of the following conditions is fulfilled:

- You manoeuvre to avoid the obstacle.
- There is no longer a risk of collision.
- An obstacle is no longer detected in front of your vehicle.

#### System limits

Full system performance is not yet available for a few seconds after switching on the vehicle or after driving off.

The system may be impaired or may not function in the following situations:

- In snow, rain, fog or heavy spray.
- If the sensors are dirty, misted up, damaged or covered.
- If the sensors are impaired due to interference from other radar sources, e.g. strong radar reflections in multi-storey car parks.
- If a loss of tyre pressure or a defective tyre has been detected and displayed.
- In complex traffic situations where objects cannot always be clearly identified.
- If pedestrians or vehicles move quickly into the sensor detection range.
- If pedestrians are hidden by other objects.



- If the typical outline of a pedestrian cannot be distinguished from the background.
- If a pedestrian is not detected as such, e.g. due to special clothing or other objects.
- In bends with a narrow radius.

### Activating or deactivating Active Brake Assist

On-board computer:

 **Settings** **Assistance**  
**Active Brake Assist**

 It is recommended that Active Brake Assist is always left activated.

 **To activate/deactivate:** press the  button. The distance warning function and the autonomous braking function of Active Brake Assist are deactivated or activated.

When the functions are deactivated, the  symbol appears in the assistance graphic in the instrument cluster display.

The next time the vehicle is started, Active Brake Assist is automatically activated.

### Function of Adaptive Brake Lights

Adaptive Brake Lights warn following traffic in an emergency braking situation with the following signals:

- By flashing the brake lamps
- By activating the hazard warning lights

If the vehicle is braked sharply from speeds above 50 km/h, the brake lamps flash rapidly. This provides traffic travelling behind you with an even more noticeable warning.

If the vehicle is travelling at speeds of more than 70 km/h at the beginning of the brake application, the hazard warning lights switch on once the vehicle is stationary. When pulling away again, the hazard warning lights switch off automatically at approximately 10 km/h.

You can also switch off the hazard warning lights using the hazard warning button (→ page 110).

### Cruise control and limiter

#### Function of cruise control

Cruise control accelerates and brakes the vehicle automatically in order to maintain a previously stored speed.

If you accelerate to overtake, for example, the stored speed is not deleted. If you remove your foot from the accelerator pedal after overtaking, cruise control will resume speed regulation back to the stored speed.

You operate cruise control using the cruise control lever. You can store any speed above 30 km/h.

Observe the notes on driving systems and your responsibility; you may otherwise fail to recognise dangers (→ page 154).

#### System limits

Cruise control may be unable to maintain the stored speed on uphill gradients. The stored speed is resumed if the uphill gradient evens out and the vehicle's speed does not fall below 30 km/h.

On long and steep downhill gradients, you should change down to a lower gear in good time. Take particular note of this when driving a laden vehicle. By doing so, you will make use of the engine's braking effect. This will take some of the strain off the brake system and prevent the brakes from overheating and wearing too quickly.

If you change wheel size on your vehicle, check it is assigned to the correct wheel size category (→ page 263). If the category is changed without recoding the control units in the vehicle, the functioning of cruise control may be impaired.

Do not use cruise control in the following situations:

- in traffic situations which require frequent changes of speed, e.g. in heavy traffic, on winding roads
- off-road or on construction sites
- on slippery or slick roads, as the drive wheels can lose traction when accelerating and the vehicle can then skid
- if there is poor visibility

#### Function of the limiter

The limiter restricts the speed of the vehicle. To adjust to the set speed quickly, the limiter applies the brakes automatically.

You can limit the speed as follows:

- Variable: for a short-term or medium-term restriction of the highest permissible speed, e.g. in built-up areas
- Permanent: for a long-term restriction of the highest permissible speed, e.g. in winter tyre mode

You can operate the variable limiter with the cruise control lever. You can store any speed above 30 km/h. You can also perform settings while the vehicle is stationary if the vehicle has been started.

Observe the notes on driving systems and your responsibility. You may otherwise fail to recognise dangers (→ page 154).

If you change wheel size on your vehicle, check it is assigned to the correct wheel size category (→ page 263). If the category is changed without recoding the control units in the vehicle, the functioning of the limiter may be impaired.

### Kickdown

If you depress the accelerator pedal beyond the pressure point (kickdown), the limiter switches to passive mode.

The instrument cluster display shows the **Limiter passive** message and you are able to exceed the stored speed.

After completion of kickdown, the variable limiter is activated again in the following situations:

- If the driven speed drops below the stored speed.
- If the stored speed is called up.
- If you store a new speed.

### Operating cruise control or the variable limiter

#### Requirements:

Cruise control

- Cruise control is selected.
- The parking brake has been released.
- ESP® is activated, but may not intervene.
- The driving speed is at least 30 km/h.
- The clutch pedal is not depressed.
- The brake pedal is not depressed.

#### Requirements:

Variable limiter

- The vehicle has been started.
- The variable limiter is selected.

### Switching between cruise control and the variable limiter

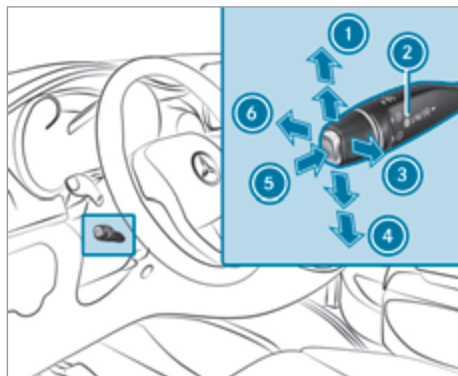

▶ Press button ⑤.

- LIM indicator lamp ② off: cruise control is selected.
- LIM indicator lamp ② lit: the variable limiter is selected.

### Storing and maintaining the current speed

▶ Briefly press the cruise control lever up ① or down ④.

The current speed is stored and the vehicle maintains this speed (cruise control) or does not exceed it (variable limiter).

When you activate cruise control, the stored speed is briefly shown in the text field of the instrument cluster display. The display also shows the  symbol and the stored speed.

When you activate the variable limiter, the instrument cluster display briefly shows the stored speed. The display also shows the **LIM** symbol and the stored speed.

 For vehicles with Active Distance Assist DISTRONIC, the segments between the start of the scale and the stored speed light up in the speedometer dial instead.

### Calling up the stored speed

 **WARNING** Risk of accident due to stored speed

If you call up the stored speed and this is lower than your current speed, the vehicle decelerates.

▶ Take into account the traffic situation before calling up the stored speed.



- ▶ Briefly pull the cruise control lever in direction .

The last stored speed is called up and the vehicle maintains this speed (cruise control) or does not exceed it (variable limiter).

If the last stored speed has previously been deleted, the currently driven speed is stored.



-  When you switch off the vehicle, the last speed stored is cleared.

### Increasing or reducing the speed

- ▶ Press the cruise control lever up  or down  as far as the 1st pressure point.

The stored speed is increased or reduced by 1 km/h.

or

- ▶ Press the cruise control lever up  or down  beyond the 1st pressure point.

The stored speed is increased or reduced by 10 km/h.



If you have set **Miles** as the unit for the digital speedometer, you can maintain any speed from 20 mph (cruise control) or set it as the limit speed (variable limiter). You can then set the limit speed in increments of 1 mph and 5 mph.

### Deactivating cruise control or the variable limiter

- ▶ Briefly press the cruise control lever forwards .

or

- ▶ Press button .

The  or  symbol and the stored speed in the instrument cluster display then go out.

-  Cruise control is deactivated in the following situations:

- you apply the brakes.
- you drive below a speed of 30 km/h.
- you shift the transmission to position .
- ESP<sup>®</sup> intervenes.

In these cases the variable limiter remains activated.

If you deactivate ESP<sup>®</sup>, or ABS or ESP<sup>®</sup> is malfunctioning, cruise control and the limiter are deactivated.

-  **Vehicles with manual transmission:** if the engine speed is very low, cruise control or the limiter is deactivated. When the transmission is in neutral or the clutch pedal is depressed for longer than six seconds, cruise control is deactivated.

If cruise control automatically deactivates, a warning tone sounds and the **Cruise control off** message appears briefly in the instrument cluster display.

### Information on the permanent limiter

-  The permanent limiter is only available in certain countries.

If the vehicle should never exceed a specific speed (e.g. for driving in winter tyre mode), you can set this speed with the permanent limiter.

You can permanently limit the speed to a value between 160 km/h and the maximum permissible speed (→ page 161).

If you accelerate the vehicle using the accelerator pedal, a message with the stored speed is shown in the instrument cluster display shortly before the set limit speed is reached.

The permanent limiter remains active even when the variable limiter is switched off. The permanent limiter does not switch to passive mode even during kickdown and the driven speed remains below the set speed.

### Setting the limit speed for winter tyres

On-board computer:

-   **Settings**  **Vehicle**  
 **Limit speed (winter tyres)**

- ▶ Change the setting and confirm using the  button.  
 By selecting **Off** you switch off the permanent limiter.

### DSR (Downhill Speed Regulation)

#### Notes on DSR

DSR supports you when driving downhill. DSR maintains a set speed for you on downhill gradients by applying the brakes as required. Maintaining the speed is dependent on the road surface conditions and the downhill gradient and cannot therefore be guaranteed in all situations.

Observe the notes on driving systems and your responsibility; you may otherwise fail to recognise dangers (→ page 154).

You can set the speed to between 4 km/h and 18 km/h using the brake and accelerator pedals or the cruise control lever.

DSR automatically controls in the following situations:

- If the vehicle is stationary, or its speed is less than 4 km/h, the speed is set to 4 km/h or it

is set to the minimum speed for the respective gear range.

- If you drive faster than 18 km/h off-road, DSR switches to standby mode. DSR remains activated, but does not brake automatically.
- If you drive downhill slower than 18 km/h, DSR sets the speed to the previously set speed.
- If you drive faster than 45 km/h, DSR switches off automatically.

### Activating/deactivating DSR

#### Requirements:

- you are driving at 40 km/h or the vehicle is stationary.

#### Activating DSR

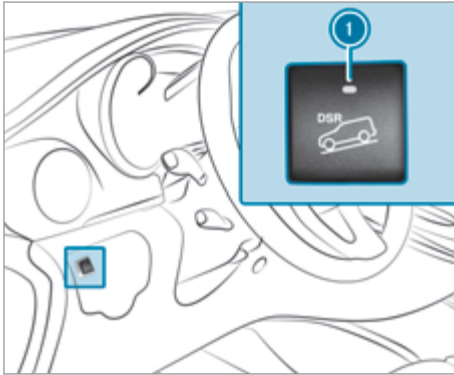

- ▶ Press the ① button. The indicator lamp in the button is lit when DSR is switched on.
- ▶ Brake or accelerate the vehicle to the desired speed between 4 km/h and 18 km/h.
- ▶ Release the brake or accelerator pedal. The current speed is stored. When stationary, 4 km/h or the minimum possible speed for each gear range is stored. DSR maintains the stored speed on the downhill gradient and brakes automatically.



When DSR is activated and the vehicle pulls away, accelerates or brakes on an incline, the speed set corresponds to the speed at which the accelerator or brake pedal is released or the cruise control lever is operated during DSR regulation. This is only the case if you are not driving faster than 18 km/h.

DSR status display in the on-board computer



#### • DSR is activated:

-  DSR and the set speed appear in the status area of the on-board computer.

#### • DSR is activated, but is not intervening:

- You are driving between 18 km/h and 45 km/h.
-  DSR is not shown in the status area of the on-board computer. In addition, the  --- km/h message appears briefly. DSR is in standby mode.

#### • DSR is inactive:

- As soon as you exceed a speed of 45 km/h.
-  DSR is not shown in the status area of the on-board computer. In addition, the  Off message appears briefly.

### Setting the speed while driving downhill

You can set the speed to between 4 km/h and, depending on the gear range, up to 18 km/h using the brake and accelerator pedals or the cruise control lever.

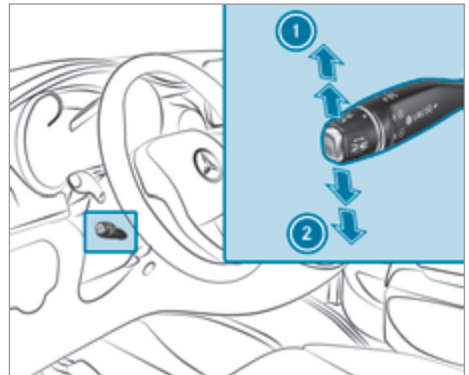

- ▶ Brake or accelerate the vehicle to the desired speed on the downhill gradient.
- ▶ Release the brake or accelerator pedal. The current speed is stored.

or

- ▶ During a DSR regulation, briefly press the cruise control lever up ① or down ② to the first pressure point. The last stored speed is increased or reduced in increments of 1 km/h.

- ❗ It may be a moment before the vehicle starts to brake to the set speed. Take this delay into account when setting the speed with the cruise control lever.

### Deactivating DSR

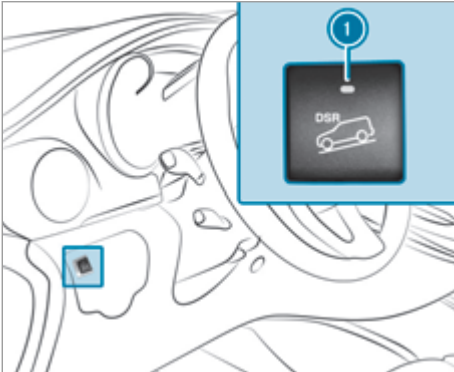

- ▶ Press the ❶ button.  
The indicator lamp in the button goes out.
- ❗ If you drive faster than 45 km/h, the DSR switches off automatically.

### Active Distance Assist DISTRONIC

#### Function of Active Distance Assist DISTRONIC

Active Distance Assist DISTRONIC is only available for vehicles with automatic transmission.

Active Distance Assist DISTRONIC maintains the set speed on free-flowing roads. If vehicles ahead are detected, the set distance is maintained, if necessary until the vehicle comes to a halt. The vehicle accelerates or brakes, depending on the distance to the vehicle in front and the set speed. The speed and distance to the vehicle in front are set and saved using the cruise control lever. The speed can be set in the range between 20 km/h and 200 km/h.

Other features of Active Distance Assist DISTRONIC:

- Depending on the preselected distance, DISTRONIC intervenes either dynamically (short distance) or to save fuel (long distance).
- Depending on the vehicle mass detected, the dynamics of the DISTRONIC intervention are reduced.

- The driving style is adapted depending on the drive program selected.
- Acceleration to the stored speed is initiated if the turn signal indicator is switched on to change to the overtaking lane.

Observe the notes on driving systems and your responsibility; you may otherwise fail to recognise dangers (→ page 154).

#### System limits

The system may be impaired or may not function in the following situations, for example:

- in snow, rain, fog or heavy spray
- if there is dirt on the radar sensors or they are covered
- if there is interference from radar sources or strong radar reflections, for example in multi-storey car parks
- in traffic situations where frequent speed changes are required, e.g. in heavy traffic or on winding roads or off-road
- on roads with steep downhill or uphill gradients
- on winding roads

The system cannot detect stationary objects unless these were previously detected as moving.

In addition, on slippery or slick roads, braking or accelerating can cause one or several of the drive wheels to lose traction and the vehicle can then skid.

Do not use Active Distance Assist DISTRONIC in these situations.

**⚠ WARNING** Risk of accident from acceleration or braking by Active Distance Assist DISTRONIC

Active Distance Assist DISTRONIC may accelerate or brake in the following cases, for example:

- If the vehicle pulls away using Active Distance Assist DISTRONIC.
- If the stored speed is called up and is considerably faster or slower than the currently driven speed.
- If Active Distance Assist DISTRONIC no longer detects a vehicle in front or does not react to relevant objects.

▶ Always carefully observe the traffic conditions and be ready to brake at all times.

- ▶ Take into account the traffic situation before calling up the stored speed.

**▲ WARNING** Risk of accident due to insufficient deceleration by Active Distance Assist DISTRONIC

Active Distance Assist DISTRONIC brakes your vehicle with up to 50% of the possible deceleration. If this deceleration is not sufficient, Active Distance Assist DISTRONIC alerts you with a visual and acoustic warning.

- ▶ Adjust your speed and maintain a suitable distance from the vehicle in front.
- ▶ Brake the vehicle yourself and/or take evasive action.

**▲ WARNING** Risk of accident if detection function of Active Distance Assist DISTRONIC is impaired

Active Distance Assist DISTRONIC does not react or has a limited reaction:

- when driving on a different lane or when changing lanes
- to pedestrians, animals, bicycles or stationary vehicles, or unexpected obstacles
- to complex traffic conditions
- to oncoming vehicles and crossing traffic

As a result, Active Distance Assist DISTRONIC may neither give warnings nor intervene in such situations.

- ▶ Always observe the traffic conditions carefully and react accordingly.

Active Distance Assist DISTRONIC may not detect narrow vehicles driving in front, e.g. motorcycles or vehicles not travelling in line with your vehicle. If the following requirements for activation are no longer fulfilled or the system is malfunctioning, Active Distance Assist DISTRONIC is automatically deactivated. If the vehicle is stationary or is moving very slowly during automatic deactivation, the transmission automatically shifts to park position **P**.

### Operating Active Distance Assist DISTRONIC

#### Requirements:

- The vehicle has been started. It may take up to two minutes of driving before Active Distance Assist DISTRONIC is ready for use.
- The parking brake has been released.

- ESP® is activated and is not intervening.
- Active Parking Assist is not active.
- The transmission is in position **D**.
- The doors and tailgate are closed.
- The driver's seat belt is fastened.

### Switching between the variable limiter and Active Distance Assist DISTRONIC

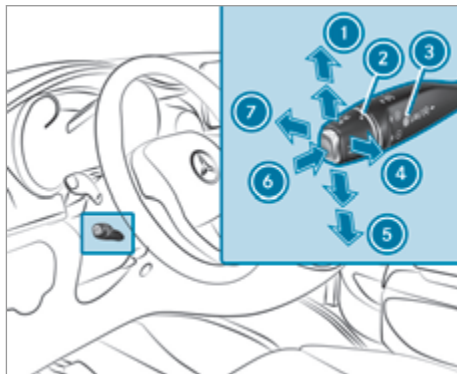

- ▶ Press button **6**.
  - LIM indicator lamp **3** off: Active Distance Assist DISTRONIC is selected.
  - LIM indicator lamp **3** lit: the variable limiter is selected.

### Activating Active Distance Assist DISTRONIC

- ▶ **To activate with the current speed:** briefly press the cruise control lever briefly up **1** or down **5** and take your foot off the accelerator pedal.

The current speed is stored and shown on the speedometer. The instrument cluster display briefly shows the set specified distance as well as the stored speed.

or

- ▶ **To activate with the stored speed:** pull the cruise control lever briefly in direction **4** and take your foot off the accelerator pedal. The speed is displayed on the speedometer. The instrument cluster display shows the set specified distance as well as the stored speed.

- i** Vehicles with Traffic Sign Assist: the speed detected by Traffic Sign Assist can be set by pulling the lever in direction **4** (→ page 176).

- Information on DISTRONIC displays (→ page 165).

If you do not fully release the accelerator pedal, the **Active Distance Assist suspended** message appears on the instrument cluster display. The distance to a slower-moving vehicle in front will then not be set. The position of the accelerator pedal will determine the speed.

When you pull the cruise control lever in direction ④ for the first time after starting the vehicle, Active Distance Assist DISTRONIC adopts the current speed. If the current speed is less than 20 km/h Active Distance Assist DISTRONIC adopts the speed of 20 km/h.

### Pulling away again with Active Distance Assist DISTRONIC

- Remove your foot from the brake pedal.
- Briefly pull the cruise control lever in direction ④.

or

- Depress the accelerator pedal briefly with force.  
The functions of Active Distance Assist DISTRONIC continue to be carried out.

### Deactivating Active Distance Assist DISTRONIC

- WARNING** Risk of an accident due to Active Distance Assist DISTRONIC being active when you leave the driver's seat

If you leave the driver's seat while the vehicle is being braked by Active Distance Assist DISTRONIC only, the vehicle can roll away.

- Always deactivate Active Distance Assist DISTRONIC and secure the vehicle to prevent it from rolling away before you leave the driver's seat.

- Briefly push the cruise control lever forwards ⑦.

or

- Brake if the vehicle is moving.

or

- Press button ⑥.  
The variable limiter is selected. LIM indicator lamp ③ in the cruise control lever lights up.

### Increasing or reducing the speed

- Press the cruise control lever up ① or down ⑤ as far as the first pressure point.  
The stored speed is increased or reduced by 1 km/h.

or

- Press the cruise control lever up ① or down ⑤ beyond the first pressure point.  
The stored speed is increased or reduced by 10 km/h.

### Increasing or reducing the specified distance from the vehicle in front

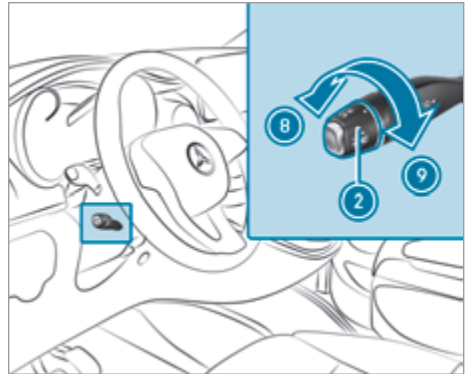

- Turn controller ② in direction ⑨ to increase the specified minimum distance and in direction ⑧ to reduce the specified minimum distance.  
The instrument cluster display briefly shows the set specified distance.

- Information on DISTRONIC displays (→ page 165).

### Displays of Active Distance Assist DISTRONIC

#### Assistance graphic

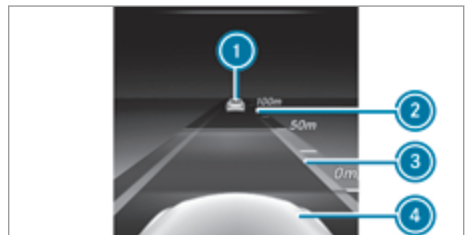

- ① Vehicle in front, if detected
- ② Distance indicator

- ③ Set specified distance
- ④ Own vehicle
- i Information about the assistance graphic menu (→ page 187).

If you set the speed, the assistance graphic briefly appears in the instrument cluster display.

### Displays on the speedometer

When Active Distance Assist DISTRONIC is activated, one or two indicator segments light up in the stored speed range of the speedometer.

If Active Distance Assist DISTRONIC detects a vehicle in front, the indicator segments, located between the speed of the vehicle in front and the stored speed, light up.

### Information on Hill Start Assist

Hill Start Assist holds the vehicle for a short time when pulling away on a hill under the following conditions:

- **Vehicles with manual transmission:** a gear is engaged.
- **Vehicles with automatic transmission:** the transmission is in position **D** or **R**.
- The parking brake has been released.

This gives you enough time to move your foot from the brake pedal to the accelerator pedal and depress it before the vehicle begins to roll.

**⚠ WARNING** Risk of accident and injury due to the vehicle rolling away

After a short time, Hill Start Assist no longer holds the vehicle.

- ▶ Swiftly move your foot from the brake pedal to the accelerator pedal. Do not leave the vehicle when it is being held by Hill Start Assist.

### HOLD function

#### HOLD function

The HOLD function is only available for vehicles with automatic transmission.

The HOLD function holds the vehicle at a standstill without requiring you to depress the brake pedal, e.g. when pulling away on steep slopes or when waiting in traffic. When you depress the accelerator pedal to pull away, the braking effect is cancelled and the HOLD function is deactivated.

The HOLD function is only an aid. The responsibility for the vehicle safely standing still remains with the driver.

#### System limits

The HOLD function is only intended to provide assistance when driving and is not a sufficient means of safeguarding the vehicle against rolling away when stationary.

- The incline cannot be greater than 30%.

#### Activating or deactivating the HOLD function

##### Requirements:

- The vehicle is stationary.
- The vehicle has been started or has been automatically switched off by the ECO start/stop function.
- All the doors and the tailgate are closed and the seatbelt is fastened.
- The parking brake has been released.
- The selector lever is in the **D**, **R** or **N** position.
- Active Distance Assist DISTRONIC is deactivated.

#### Activating the HOLD function

**⚠ WARNING** Risk of an accident due to the HOLD function being active when you leave the vehicle

If the vehicle is only braked with the HOLD function it could, in the following situations, roll away:

- If there is a malfunction in the system or in the power supply.
- If the HOLD function is deactivated by depressing the accelerator pedal or brake pedal, e.g. by a vehicle occupant.
- ▶ Always secure the vehicle against rolling away before you leave it.

- ▶ Depress the brake pedal until the **HOLD** display appears in the instrument cluster display. The HOLD function is activated. You can release the brake pedal.

- i If depressing the brake pedal the first time does not activate the HOLD function, wait briefly and then try again.

#### Deactivating the HOLD function

- ▶ Depress the accelerator pedal to pull away.
- or

- ▶ Depress the brake pedal until the **HOLD** display in the instrument cluster disappears from the driver's display.

The HOLD function is deactivated in the following situations:

- Active Distance Assist DISTRONIC is activated.
- The transmission is shifted to position **P**.
- The vehicle is secured with the electric parking brake.

In the following situations, the vehicle is held by transmission position **P** and/or by the electric parking brake:

- The driver's side seat belt is not fastened, or a door or the tailgate is open.
- The vehicle is switched off without ECO start/stop function.

## PARKTRONIC

### Function of PARKTRONIC

PARKTRONIC is an electronic parking assistance system with ultrasonic sensors. The system monitors the area around your vehicle using sensors on the front bumper and on the rear bumper. PARKTRONIC indicates visually and audibly the distance between your vehicle and an object.

The warning ranges in front of and behind the vehicle are indicated by different warning tones.

PARKTRONIC is only an aid. It is not a substitute for you paying attention to the surroundings. You are always responsible for safe manoeuvring, parking and exiting a parking space. Make sure that there are no persons, animals or objects etc. in the manoeuvring area while manoeuvring and parking or exiting parking spaces.

Requirements for automatic activation:

- The vehicle is switched on.
- The parking brake has been released.

The selected transmission position determines whether the front and/or rear area is monitored.

Front area only:

- Forward gear (manual transmission)
- Idle (manual transmission)
- Transmission position **D**

Front and rear area:

- Reverse gear (manual transmission)
- Transmission position **R**
- Transmission position **N**

Regardless of the transmission position, PARKTRONIC automatically monitors the area behind the vehicle if the vehicle begins to roll backwards, e.g. after stopping on an uphill gradient.

PARKTRONIC is deactivated at speeds above 18 km/h. PARKTRONIC is reactivated at speeds below 16 km/h.

**Vehicles with trailer hitch:** PARKTRONIC is deactivated for the rear area when you establish an electrical connection to the trailer or to a rear bicycle rack.

After uncoupling the trailer, unplug the 7-pin plug adapter from the socket. Otherwise, PARKTRONIC remains deactivated for the rear area.

Remove a detachable trailer coupling if it is no longer required. PARKTRONIC measures the minimum detection range to an obstacle from the bumper, not the ball neck.

### Warning displays

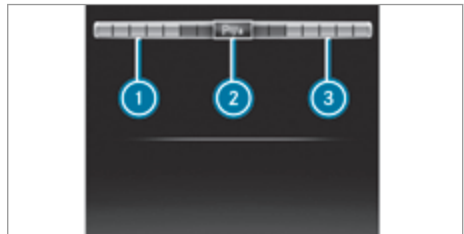

Front zone warning displays in the display of the instrument cluster

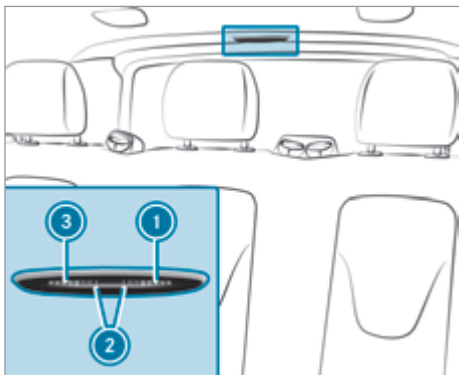

Rear area warning display in the rear at the centre of the roof lining

- ① Warning segments for the left side of the vehicle
- ② Measurement operational readiness indicator
- ③ Warning segments for the right side of the vehicle

At least one segment will light up as the vehicle approaches an obstacle, depending on the vehicle's distance from the obstacle.

In addition, warning tones are emitted. When the distance to the obstacle is sufficient, you will hear an intermittent warning tone. The shorter the distance to the obstacle, the shorter the frequency of the intermittent warning tones becomes. When the minimum distance is reached, you hear a continuous warning tone.

The warning display for each side of the vehicle is divided into five yellow and two red segments. PARKTRONIC is active if measurement operational readiness indicator ② lights up.

### System limits

PARKTRONIC may not take the following obstacles into account:

- obstacles below the detection range, e.g. persons, animals or objects
- obstacles above the detection range, e.g. overhanging loads, overhangs or loading ramps of lorries

The sensors must be free of dirt, ice and slush. They may otherwise not function or their function may be impaired. Clean the sensors regularly, taking care not to scratch or damage them (→ page 235).

### Problems with PARKTRONIC



There is a malfunction if only the red segments of the warning display light up. In addition, a warning tone sounds for approximately two seconds. If problems persist, have PARKTRONIC checked at a qualified specialist workshop.

If the warning indicators are displaying implausible distances, it may be due to the following causes:

- **The sensors are dirty:** clean the sensors. Observe the notes on care of vehicle parts (→ page 235).
- **Licence plates or other detachable parts in the vicinity of the sensors are not correctly fastened:** check the licence plate or the detachable parts for correct fit.
- **Interference by another source of radio or ultrasound waves:** check the function of PARKTRONIC at another location.

### Deactivating/activating PARKTRONIC



- ▶ Press the  button. If PARKTRONIC is deactivated, the indicator lamp of the  button lights up.

### Reversing camera

#### Function of the reversing camera

The reversing camera is located next to the tailgate handle and is protected from raindrops and dust by means of a flap. When the reversing camera is activated, this flap opens (→ page 154).

The flap closes again when you have ended the manoeuvring process or you switch the vehicle off.

For technical reasons, the flap may remain open briefly after the reversing camera has been deactivated.

You can activate the automatic display function of the reversing camera in the multimedia system (→ page 172). When you engage reverse gear, the image from the reversing camera is shown automatically in the media display. Dynamic guide lines show the path the vehicle will take for the current steering movement. This helps you to orient yourself and to avoid obstacles when reversing.

The reversing camera is only an aid. It is not a substitute for you paying attention to the surroundings. You are always responsible for safe manoeuvring and parking. Make sure that there are no persons, animals or objects etc. in the manoeuvring area while manoeuvring and parking in parking spaces.

You can use the softkeys located below or to the side to choose between the following views:

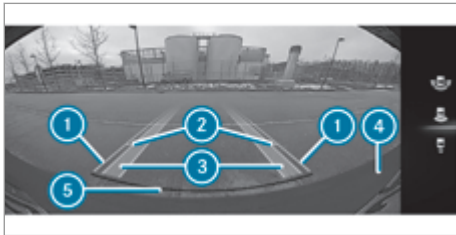

#### Normal view

- ① Yellow guide line, vehicle width (driven surface) depending on the current steering angle (dynamic)
- ② Yellow guide line at a distance of approximately 1.0 m from the rear area
- ③ Yellow path marking the course the tyres will take at the current steering position (dynamic)
- ④ Bumper
- ⑤ Red guide line at a distance of approximately 0.3 m from the rear area

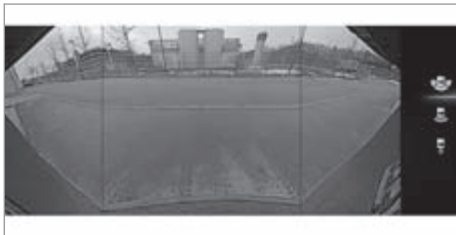

#### Wide-angle view

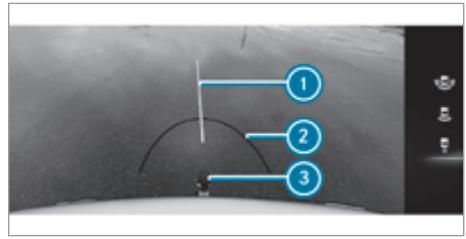

#### Trailer view (vehicles with a trailer hitch)

- ① Yellow guide line, locating aid
- ② Red guide line at a distance of approximately 0.3 m to the ball head of the trailer hitch
- ③ Ball head of the trailer hitch

Observe the notes on cleaning and care of the reversing camera.

The reversing camera may show a distorted view of obstacles, show them incorrectly or not at all. The reversing camera cannot show all objects which are very near to or under the rear bumper. It will not warn you of a collision, people or objects.

The area behind the vehicle is displayed as a mirror image, as in the inside rearview mirror.

When you shift out of reverse gear, the dynamic guide lines are faded out. If, after shifting out of reverse gear, you drive faster than 16 km/h, the reversing camera is deactivated.

#### System limits

The reversing camera will not function or will only partially function in the following situations:

- if the tailgate is open
  - if there is heavy rain, snow or fog
  - if the light conditions are poor, e.g. at night
  - if the camera lens is covered, dirty or misted up
  - if cameras, or vehicle components in which the cameras are fitted, are damaged. Have the cameras, their positions and their setting checked at a qualified specialist workshop.
- ⓘ The media display contrast may be impaired due to direct sunlight or other light sources. In this case, pay particular attention.
- ⓘ Have the media display repaired or replaced if, for example, pixel errors considerably restrict its use.

**i** Objects that are not at ground level appear further away than they actually are. This includes, for example:

- the bumper of a vehicle parked behind
- the drawbar of a trailer
- the ball neck of a trailer hitch
- the tail-end of a lorry
- slanted posts

Only use the guide lines of the camera image for orientation. Do not travel further than the lowest horizontal guide line when approaching objects. You may otherwise damage your vehicle and/or the object.

### Opening the reversing camera cover

Multimedia system:

→  **Settings** **Vehicle**

→ **Rear view camera**

▶ Select **Open camera cover**.

**i** The camera cover closes automatically after a while or when the vehicle is switched off with the cover open.

## 360° Camera

### Function of the 360° Camera

The system consists of four cameras. The cameras cover the immediate vehicle surroundings. The system assists you, for example, when parking or at exits with reduced visibility.

The 360° Camera is only an aid. It is not a substitute for you paying attention to the surroundings. You are always responsible for safe manoeuvring and parking. Make sure that there are no persons, animals or objects etc. in the manoeuvring area while manoeuvring and parking in parking spaces.

The system evaluates images from the following cameras:

- Reversing camera
- Front camera
- Two side cameras in the outside mirrors

### Views of the 360° Camera

You can use the softkeys located below or to the side to choose between the following views:



View with softkeys located at the bottom

- ① Wide-angle view, front
- ② Top view with image from the front camera
- ③ Top view with the image from the forward-facing side cameras (front wheel view)
- ④ Wide-angle view, rear
- ⑤ Top view with image from the reversing camera
- ⑥ Top view with the image from the rearward-facing side cameras (rear wheel view)
- ⑦ Top view with trailer view (vehicles with a trailer hitch)

### Top view



- ① Path indicating the route the vehicle will take with the steering wheel in its current position
- ② Warning display of Parking Assist PARKTRONIC
- ③ Your vehicle from above

The colour of the individual segments of warning display ② is based on the distance to the detected obstacle:

- **Yellow segments:** obstacles at a distance between approx. 0.4 m and 1.0 m
- **Red segments:** obstacles at a very short distance of approx. 0.3 m or less

When Parking Assist PARKTRONIC is operational and no object is detected, the segments of the currently active side are indicated using thin, yellow lines.

## Guide lines

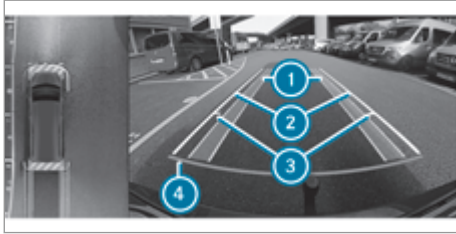

- ① Yellow path marking the course the tyres will take at the current steering position (dynamic)
  - ② Yellow guide line, vehicle width (driven surface) depending on the current steering angle (dynamic)
  - ③ Mark at a distance of approx. 1.0 m
  - ④ Red guide line at a distance of approximately 0.3 m from the rear area
- ⓘ The guide lines in the media display show the distances to your vehicle. The distances apply at road level.  
In trailer mode, the guide lines are shown at the level of the trailer hitch.

### Trailer view (vehicles with a trailer hitch)

The trailer view displays the trailer hitch ball head and a locating guide for manoeuvring.

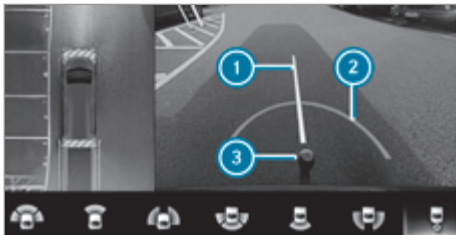

- ① Yellow guide line, locating aid
- ② Red guide line at a distance of approximately 0.3 m to the ball head of the trailer hitch
- ③ Ball head of the trailer hitch

### Side camera views

The front or rear sides of the vehicle can be seen in these views.



Example: forward-facing side cameras (front wheel view)

- ① Guide line of external vehicle dimensions with outside mirrors folded out (left side of the vehicle)
- ② Guide line of external vehicle dimensions with outside mirrors folded out (right side of the vehicle)

### System limits

The 360° Camera will not function or will only partially function in the following situations:

- if the doors or tailgate are open
  - if the exterior mirrors are folded in
  - if there is heavy rain, snow or fog
  - if the light conditions are poor, e.g. at night
  - if the cameras are exposed to very bright light, white lines may appear in the camera image
  - if the camera lens is covered, dirty or misted up.
  - if cameras, or vehicle components in which the cameras are fitted, are damaged. Have the cameras, their positions and their setting checked at a qualified specialist workshop.
- ⓘ Do not use the 360° Camera under such circumstances. You could otherwise injure others or collide with objects when parking the vehicle.
- ⓘ Have the media display repaired or replaced if, for example, pixel errors considerably restrict its use.

If you change wheel size on your vehicle, check it is assigned to the correct wheel size category (→ page 263). If the assignment changes without recoding the control units in the vehicle, the 360° Camera cannot calibrate properly. The guide lines at road level or at the level of the trailer coupling will then not be displayed correctly.

See the notes on cleaning the 360° Camera (→ page 235).

## Switching the 360° Camera on or off

### Requirements:

- The vehicle is switched on.
- The multimedia system is activated.
- You are driving at moderate speeds.

### Activating

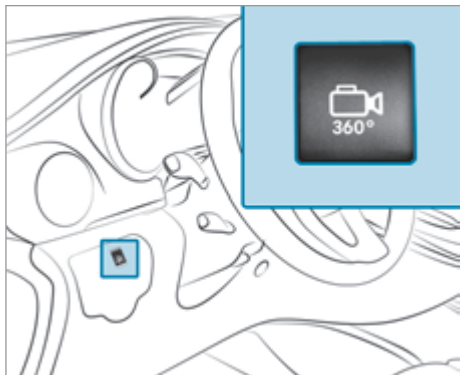

- ▶ Press the  button.

or

- ▶ If the automatic camera view function is activated in the multimedia system, engage reverse gear (→ page 172).
- ▶ Select the appropriate view using the displayed softkeys (→ page 170).

### Deactivating

- ▶ Press the  button.

or

- ▶ Drive forwards at a speed above 16 km/h.

or

- ▶ Shift the automatic transmission to position **P**.

### Activating/deactivating automatic operation of the reversing camera

The reversing camera is only an aid. It is not a substitute for you paying attention to the surroundings. You are always responsible for safe manoeuvring, parking and exiting a parking space. Make sure that no persons, animals or objects etc. are in the path of your vehicle. Pay attention to your surroundings and be ready to brake at all times.

Multimedia system:

 **▶▶ Settings ▶▶ Assistance**

**▶▶ Camera & parking**

**▶ Auto reversing camera** Activate or deactivate.

## Active Parking Assist

### Function of Active Parking Assist

Active Parking Assist is an electronic parking assistance system which automatically locates and measures parking spaces on both sides of the vehicle when you are driving forwards up to a speed of approximately 35 km/h.

If all requirements are met, the  display appears in the instrument cluster display. The system then independently locates and measures parallel and perpendicular parking spaces on both sides of the vehicle.

When Active Parking Assist has detected parking spaces, the  display appears in the instrument cluster display. The arrows show on which side of the road free parking spaces are located.

Active Parking Assist displays parking spaces on the co-driver side as standard. The parking spaces on the driver's side are only displayed if you operate the turn signal on the driver's side. When parking on the driver's side, you must operate the turn signal until you have started active parking assistance by pressing the  steering-wheel button.

Active Parking Assist can assist you with an active steering intervention and brake application during parking and exiting the parking space. The active brake application is dependent on the country-specific version of the vehicle. On vehicles with manual transmission, active parking assistance is limited exclusively to power-steering assistance.

Active Parking Assist is only an aid. It is not a substitute for your attention to the surroundings. You are always responsible for safe manoeuvring, parking and exiting a parking space. Make sure that no persons, animals or objects etc. are in the path of your vehicle.

Active Parking Assist is cancelled in the following cases, among others:

- Parking Assist PARKTRONIC is deactivated.
- You steer.
- You apply the parking brake.
- Parking using Active Parking Assist is no longer possible.
- You exceed a speed of 10 km/h.
- A wheel spins and ESP® intervenes or fails.
- You engage transmission position **P**.

- You open the driver's door or a sliding door on vehicles with a manual transmission.
- You open a door or the tailgate, or unfasten your seat belt, on vehicles with an automatic transmission.

PARKTRONIC is deactivated for the rear area when you have a trailer coupled up and establish an electrical connection between your vehicle and the trailer. Active Parking Assist is then not available.

### System limits

Objects located above or below the detection range of Active Parking Assist are not detected when the parking space is being measured. These are also not taken into account when the parking manoeuvre is calculated, e.g. overhanging loads, overhangs or loading ramps of lorries, or the boundaries of parking spaces. In some circumstances, Active Parking Assist may therefore guide you into the parking space prematurely.

**⚠ WARNING** Risk of accident due to objects located above or below the detection range of Active Parking Assist

If there are objects above or below the detection range, the following situations may arise:

- Active Parking Assist may steer too early.
- The vehicle may not stop in front of these objects.

There is a danger of collision!

- ▶ In these situations, do not use Active Parking Assist.

Snowfall or heavy rain may lead to a parking space being measured inaccurately. Parking spaces that are partially occupied by trailer drawbars might not be identified as such or be measured incorrectly. Only use Active Parking Assist on level, high-grip ground.

Do not use Active Parking Assist in the following situations, among others:

- in extreme weather conditions such as ice, packed snow or in heavy rain
- when cornering
- for parking spaces which are not on the same level as the road, e.g. not on the pavement
- when transporting a load that protrudes beyond the vehicle
- when snow chains are fitted

Active Parking Assist may also display parking spaces that are not suitable for parking, for example:

- parking spaces where parking is prohibited
- parking spaces on unsuitable surfaces

Active Parking Assist will not assist you with parking spaces perpendicular to the direction of travel in the following situations:

- if two parking spaces are located immediately next to each other
- if the parking space is immediately next to a low obstacle such as a kerb
- if you are parking forwards

Active Parking Assist will not assist you with parking spaces parallel or perpendicular to the direction of travel in the following situations:

- if the parking space is on a kerb
- if the system deems the parking space to be blocked, such as by foliage or grass paving blocks
- if the area is too small for the vehicle to manoeuvre into
- if the parking space is bordered by an obstacle, e.g. a tree, a post or a trailer

### Parking using Active Parking Assist

**⚠ WARNING** Risk of accident due to insufficiently securing the vehicle against rolling away when exiting the vehicle

If you leave the driver's seat when the vehicle is being braked by Active Parking Assist only, it could roll away in the following situations:

- if there is a malfunction in the system or in the power supply.
- if the electrical system in the engine compartment, the battery or the fuses are tampered with.
- if the battery is disconnected.
- if the vehicle is accelerated, e.g. by a vehicle occupant.

- ▶ Before leaving the driver's seat, always secure the vehicle against rolling away.

- ▶ Bring the vehicle safely to a stop when the parking symbol with an arrow shows the desired parking space.

**⚠ WARNING** Risk of accident due to vehicle swinging out while parking or pulling out of a parking space

While parking or pulling out of a parking space, the vehicle swings out and can drive onto areas of the oncoming lane.

This could cause you to collide with objects or other road users.

- ▶ Pay attention to objects and other road users.
- ▶ Where necessary, stop the vehicle or cancel the parking procedure with Park-  
ing Pilot.

▶ **Vehicles with manual transmission:** shift to reverse gear.

▶ **Vehicles with automatic transmission:** shift the transmission to position **[R]**.  
The instrument cluster display shows the **Start Parking Assist? Yes: OK No: [↩]** message and the location of the parking space.

▶ **To cancel the process:** press the **[↩]** steering-wheel button or drive off.

or

▶ **To park using active parking assistance:** press the **[OK]** steering-wheel button.

The **Parking Assist in operation Accelerate and brake Observe surroundings** message is shown in the instrument cluster display.

▶ Release the steering wheel.

▶ Reverse the vehicle, being ready to brake at all times. Reverse slowly, and do not drive faster than 10 km/h. Parking assistance is otherwise cancelled and Active Parking Assist is stopped. On vehicles with automatic transmission, when the vehicle approaches the rear border of the parking space, Active Parking Assist can brake it to a standstill.

▶ Stop at the rear border of the parking space. Stop when PARKTRONIC sounds the continuous warning tone, if not before.

Manoeuvring may be required in tight parking spaces. Observe the messages in the instrument cluster display.

On completion of the parking procedure, the **Active Parking Assist finished** message appears and an acoustic signal sounds. Active Parking Assist no longer supports you with steering interventions and brake applications.

## Exiting a parking space with Active Parking Assist

### Requirements:

- The vehicle has been parked parallel to the direction of travel using Active Parking Assist.
- The border of the parking space must be high enough at the front and the rear; a kerb, for instance, is not sufficient.
- The border of the parking space must not be too wide. Your vehicle can be manoeuvred into a position at a maximum angle of 45° to the starting position in the parking space.
- A manoeuvring distance of at least 1 m must be available.

Please note that you are responsible for the vehicle and surroundings during the entire parking procedure.

▶ Start the vehicle.

▶ Switch on the turn signal on the side you intend to exit the parking space.

**⚠ WARNING** Risk of accident due to vehicle swinging out while parking or pulling out of a parking space

While parking or exiting a parking space, the vehicle swings out and can drive onto areas of the oncoming lane.

This could cause you to collide with objects or other road users.

- ▶ Pay attention to objects and other road users.
- ▶ Where necessary, stop the vehicle or cancel the parking procedure with Active Parking Assist.

▶ **Vehicles with manual transmission:** engage 1st gear or reverse gear.

▶ **Vehicles with automatic transmission:** shift the transmission to position **[D]** or **[R]**.

The **Start Parking Assist? Yes: OK No: [↩]** message is shown in the instrument cluster display.

▶ **To cancel the process:** press the **[↩]** steering-wheel button or drive off.

or

▶ **To exit the parking space using active parking assistance:** press the **OK** steering-wheel button.

The **Parking Assist in operation Accelerate and brake Observe surroundings** message is shown in the instrument cluster display.

▶ Release the steering wheel.

▶ Pull away and be ready to brake at all times. Reverse slowly, and do not drive faster than 10 km/h. Parking assistance is otherwise cancelled and Active Parking Assist is stopped. On vehicles with automatic transmission, when the vehicle approaches the rear border of the parking space, Active Parking Assist can brake it to a standstill.

Manoeuvring may be required in tight parking spaces. Observe the messages in the instrument cluster display.

On completion of the parking procedure, the **Active Parking Assist finished** message appears and an acoustic signal sounds. Active Parking Assist no longer supports you with steering interventions and brake applications.

The parking assistance function of Active Parking Assist is stopped. You will then have to steer and merge into traffic on your own. PARKTRONIC is still available.

## ATTENTION ASSIST

### Function of ATTENTION ASSIST

ATTENTION ASSIST can assist you on long, monotonous journeys, e.g. on motorways and trunk roads. If ATTENTION ASSIST detects indicators of fatigue or increased lapses in concentration on the part of the driver, it suggests taking a break.

ATTENTION ASSIST is only an aid. It cannot always detect drowsiness or increased lapses in concentration in good time. The system is not a substitute for a well-rested and attentive driver. On long journeys, take regular and timely breaks that allow you to rest properly.

If fatigue or increased lapses in concentration are detected, the **ATTENTION ASSIST: Take a break!** warning appears in the instrument cluster.

You can acknowledge the message and take a break if necessary. If you do not take a break and ATTENTION ASSIST continues to detect increasing lapses in concentration, you will be warned again after a minimum of 15 minutes.

If a warning is displayed in the instrument cluster, the multimedia system offers to search for a rest

area. You can select a rest area and start navigation to this rest area. This function can be activated and deactivated in the multimedia system.



You can have the current ATTENTION ASSIST assessment displayed using the **Assistance graphic** menu in the on-board computer (→ page 187).

The following information is displayed:

- the journey length since the last break
- the attention level determined by ATTENTION ASSIST:
  - the fuller the bar is, the higher the detected attention level is
  - the bar empties as attentiveness decreases

If ATTENTION ASSIST cannot calculate the attention level and cannot issue a warning, the **System suspended** message appears.

The bar display is then dimmed. This is the case, for example, if you are predominantly driving at a speed below 60 km/h or above 200 km/h.

### System limits

ATTENTION ASSIST is active in the 60 km/h to 200 km/h speed range.

The functionality of ATTENTION ASSIST is restricted, and warnings may be delayed or not occur at all, in the following situations:

- the journey lasts less than approximately 30 minutes
- the road condition is poor (uneven road surface or potholes)
- the vehicle is subjected to a strong crosswind
- you have a sporty driving style (high cornering speeds or high rates of acceleration)
- the time is set incorrectly
- you change lanes and vary your speed frequently in active driving situations

The ATTENTION ASSIST drowsiness or alertness assessment is deleted and restarted when continuing the journey in the following situations:

- you switch off the vehicle
- you unfasten your seat belt and open the driver's door (e.g. to change drivers or take a break)

### Deactivating or activating ATTENTION ASSIST

On-board computer:

→  >> Settings >> Assistance  
>> ATTENTION ASSIST

▶ Change the setting and confirm using the  button.

When ATTENTION ASSIST is deactivated, the  symbol appears in the assistance graphic in the instrument cluster display.

You can choose between the following settings:

- **Off**
- **Standard:** normal system sensitivity.
- **Sensitive:** higher system sensitivity. The driver is warned earlier and the attention level detected by the system is adapted accordingly.

### Traffic Sign Assist

#### Function of Traffic Sign Assist

Traffic Sign Assist aids you by displaying detected speed limits and overtaking restrictions in the instrument cluster.

Since Traffic Sign Assist also uses the data stored in the navigation system, it can update the display in the following situations without detecting traffic signs (country-specific).

The camera also detects traffic signs with a restriction indicated by an additional sign (e.g. when wet).

 Traffic signs are only displayed with the restriction indicated by an additional sign in the following cases:

- the traffic signs must be observed with the restriction
- the system is unable to clearly determine whether the restriction applies

If the system detects that you are driving onto a section of road in the wrong direction of travel, it triggers a warning. This function is not available in all countries.

Traffic Sign Assist is only an aid and is not always able to correctly display speed limits and overtak-

ing restrictions. The actual traffic signs always have priority over the Traffic Sign Assist display.

Observe the notes on driving systems and your responsibility; you may otherwise fail to recognise dangers (→ page 154).

#### Instrument cluster display

The Traffic Sign Assist display appears in the **Assistance graphic** menu of the on-board computer (→ page 187).



- ① Permissible speed
- ② Permissible speed when there is a restriction
- ③ Additional sign with restriction (example: unknown restriction)

If Traffic Sign Assist is not available or cannot determine the maximum permissible speed, the following display appears in the assistance graphic:



#### System limits

The system may be impaired or may not function in the following situations:

- If there is poor visibility, e.g. due to insufficient illumination of the road, highly variable shade conditions, rain, snow, fog or heavy spray.
- If there is glare, e.g. from oncoming traffic, direct sunlight or reflections.
- If there is dirt on the windscreen in the vicinity of the multifunction camera or if the camera is misted up, damaged or obscured.
- If the traffic signs are hard to detect, e.g. due to dirt, snow or insufficient lighting, or because they are covered.
- If signs are ambiguous, e.g. road signs in road-works or in adjacent lanes.
- If the information in the navigation system's digital map is incorrect or out-of-date.

## Activating/deactivating the Traffic Sign Assist warning function

On-board computer

**Settings** >> **Assistance**  
 >> **Traffic Sign Assist**

▶ **To activate/deactivate:** press the **OK** button.

When the warning function is active and you pass a traffic sign, the instrument cluster shows the traffic regulations (speed limit and overtaking restriction) for five seconds. The previous menu then reappears automatically.

The wrong-way warning remains active if you deactivate the warning function of Traffic Sign Assist.

## Blind Spot Assist

### Function of Blind Spot Assist

Blind Spot Assist uses two lateral, rear-facing radar sensors to monitor the area directly next to and on the side behind the vehicle.

**⚠ WARNING** Risk of accident despite Blind Spot Assist

Blind Spot Assist does not react to either stationary objects or vehicles approaching and overtaking you at a greatly different speed.

Blind Spot Assist cannot warn drivers in these situations.

▶ Always pay careful attention to the traffic situation and maintain a safe distance at the side of the vehicle.

Observe the notes on driving systems and your responsibility; you may otherwise fail to recognise dangers (→ page 154).

If a vehicle is detected above speeds of approximately 12 km/h and this vehicle subsequently enters the monitoring range directly next to your vehicle, the warning lamp in the outside mirror lights up red.

If a vehicle is detected close to your vehicle in the lateral monitoring range and you switch on the turn signal indicator in the corresponding direction, a warning tone sounds. The red warning lamp in the outside mirror flashes. If the turn signal indicator remains switched on, all other detected vehicles are indicated only by the flashing of the red warning lamp.

When you overtake a vehicle, the warning only occurs if the difference in speed is less than approximately 20 km/h.

## System limits

Blind Spot Assist may be limited in the following situations:

- if there is dirt on the sensors or the sensors are obscured
- if there is poor visibility, e.g. due to fog, heavy rain, snow or spray
- if narrow vehicles are within the monitoring range, e.g. bicycles
- if the road has very wide or very narrow lanes
- if vehicles are not driving in the middle of their lane

Warnings may be issued in error when driving close to crash barriers or similar solid lane borders. Warnings may be interrupted when driving alongside long vehicles, for example lorries, for a prolonged time.

Blind Spot Assist is not operational when reverse gear is engaged.

If you couple up a trailer, make sure that you have correctly established the electrical connection. Blind Spot Assist is then deactivated and the **Blind Spot Assist currently unavailable** See Owner's Manual message appears in the instrument cluster display.

### Activating/deactivating Blind Spot Assist

On-board computer:

**Settings** >> **Assistance**  
 >> **Blind Spot Assist**

▶ **To activate/deactivate:** press the **OK** button.

When Blind Spot Assist is activated, grey radar waves propagating toward the rear appear next to the vehicle in the assistance graphic in the instrument cluster display. If you drive faster than 12 km/h with Blind Spot Assist activated, the radar waves in the assistance graphic are displayed in green. Blind Spot Assist is ready for use.

If you switch on the vehicle while Blind Spot Assist is activated, the warning lamps in the outside mirrors light up for approx. 1.5 seconds.

## Rear Cross Traffic Alert

### Function of Rear Cross Traffic Alert

**i** The system is only available for vehicles with Blind Spot Assist.

The system uses the radar sensors in the bumper. This way the area adjacent to the vehicle is continually monitored. If the radar sensors are obscured

by vehicles or other objects, detection is not possible.

**i** Also read the notes on Blind Spot Assist (→ page 177).

The system can warn of crossing traffic when reversing out of a parking space. If the system detects a vehicle, the warning lamp in the outside mirror on the corresponding side lights up red. In a critical situation, an additional warning tone sounds.

The Rear Cross Traffic Alert function is active under the following conditions:

- Blind Spot Assist is activated.
- Reverse gear is engaged or the vehicle is reversing at walking pace.

The Rear Cross Traffic Alert function is unavailable when driving with a trailer.

## Lane Keeping Assist

### Function of Lane Keeping Assist

Lane Keeping Assist serves to protect you against unintentionally leaving your lane. You are also warned by a noticeable vibration in the steering wheel and by the status symbol flashing in the instrument cluster. Lane Keeping Assist is only an aid and is not intended to keep the vehicle in the lane without the driver's cooperation.

Observe the notes on driving systems and your responsibility; you may otherwise fail to recognise dangers (→ page 154).

The function is available in the speed range between 60 km/h and 200 km/h.

The warning is issued when the following conditions are met at the same time:

- If Lane Keeping Assist detects lane markings.
- If a front wheel drives over lane markings.

To ensure that you are warned only when necessary and in good time if you cross the lane marking, the system detects certain conditions and warns you accordingly.

The warning vibration occurs earlier under the following conditions:

- you approach the outer lane marking on a bend.
- the road has very wide lanes, e.g. a motorway.
- the system detects solid lane markings.

The warning vibration occurs later under the following conditions:

- you are driving on a road with narrow lanes.
- you cut the corner on a bend.

### System limits

The system may be impaired or may not function in the following situations:

- If there is poor visibility, e.g. due to insufficient illumination of the road, if there are highly variable shade conditions or in rain, snow, fog or spray.
- Glare from oncoming traffic, direct sunlight or reflections.
- There is dirt on the windscreen in the vicinity of the multifunction camera or the camera is misted up, damaged or obscured.
- No or several unclear lane markings are present for one lane, e.g. in a construction area.
- If the lane markings are worn away, dark or covered up.
- If the distance to the vehicle in front is too short and thus the lane markings cannot be detected.
- The lane markings change quickly, e.g. lanes branch off, cross one another or merge.
- The carriageway is very narrow and winding.

### Activating/deactivating Lane Keeping Assist

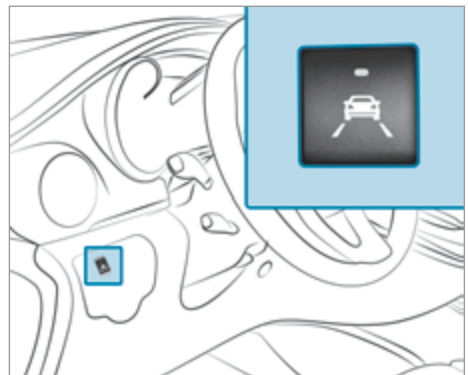

▶ Press the  button.

If the indicator lamp in the button is lit, Lane Keeping Assist is activated. If all conditions have been satisfied, there may be a warning.

If Lane Keeping Assist is activated and you are driving at speeds above 60 km/h and lane markings are detected, the lines in the assis-



tance display menu of the on-board computer are shown in green. Lane Keeping Assist is ready for use.

When the system switches over, the **Lane Keeping Assist on** or **Lane Keeping Assist off** message is shown briefly in the instrument cluster display.

-  You can find information on the assistance graphic menu under "Assistance graphic" (→ page 187).

### Setting the sensitivity of Lane Keeping Assist

On-board computer:

  **Settings** **» Assistance**  
**» Lane Keeping Assist**

-  Select the **Standard** or **Adaptive** setting.

In the **Standard** setting, no warning vibration occurs in the following situations:

- you operate the turn signal in the corresponding direction. In this event, the warnings are suppressed for a certain period of time.
- a driving safety system intervenes or regulates, such as ABS, BAS or ESP®.

In the **Adaptive** setting, there will also be no warning vibration in the following situations:

- you accelerate hard, e.g. kickdown.
- you brake hard.
- you steer actively, e.g. swerve to avoid an obstacle or change lane quickly.
- you cut the corner on a sharp bend.

## Trailer operation

### Notes on trailer operation

 **WARNING** Risk of accident and injury if the tongue weight is exceeded

The carrier system may detach from the vehicle, thereby endangering other road users.

-  Always comply with the permissible tongue weight when using a carrier.

You can find specifications regarding the ball neck on the trailer's identification plate. You can find specifications regarding the trailer on the towing vehicle's identification plate and in the Technical Data (→ page 282).

 **NOTE** The operating permit may be invalidated due to the illegal installation of trailer hitches

The installation – including retrofitting – of a non-folding or non-removable trailer hitch that even partially conceals the license plate or the lighting system is prohibited.

-  Observe the applicable legal regulations for the installation of trailer hitches.

You can attach carrier systems such as a bicycle rack or load-bearing implement to the ball neck. When carrier systems are used on the ball neck, the maximum load capacity is 75 kg.

If the trailer coupling is detachable, it is essential to comply with the operating instructions of the trailer coupling manufacturer.

Place your vehicle/trailer combination on surfaces that are as even as possible and secure it against rolling away (→ page 152). Couple and uncouple the trailer carefully.

Note the following regarding the tongue weight:

- Make full use of the maximum tongue weight, where possible.
- Never fall below a legally prescribed minimum tongue weight; the tongue weight must always be positive.
- Do not exceed or fall below the permissible tongue weights – this must be observed during loading and unloading of the trailer.

Do not exceed the following values:

- Permitted braked or unbraked towing capacity  
The maximum permissible towing capacity for unbraked trailers is 750 kg.
- Permissible rear axle load of the towing vehicle
- Permissible gross weight of the towing vehicle
- Permissible gross weight of the trailer
- Permissible gross combination weight
- Maximum permissible speed of the trailer

The relevant permitted values, which must not be exceeded, can be found in the following places:

- In your vehicle documents
- On the identification plate of the trailer hitch
- On the trailer's identification plate
- On the vehicle identification plate

If there are discrepancies between the values, the lowest one shall apply.

Before driving off, ensure the following:

- The tyre pressure on the rear axle of the towing vehicle has been set for the maximum load.
- The headlamps have been set correctly.

Comply with the maximum permissible speed of 80 km/h or 100 km/h, even in countries in which higher speeds are permitted for vehicle/trailer combinations.

- i** During trailer operation, remember that PARKTRONIC is available only to a limited extent, if at all.
- i** The height of the ball head will change depending on the vehicle's load. In this case, use a trailer with a height-adjustable drawbar.

### Vehicles with a detachable trailer coupling

**!** **NOTE** Increased risk of damage to property due to attached ball neck

- ▶ When the trailer is not coupled or the bicycle rack is attached, fold in the ball neck.

Reduce the risk of damage to the trailer coupling and contribute to environmental protection. If you do not need the ball neck, remove it from the ball neck mount and fit its cover in the rear bumper (→ page 180). Only with the cover fitted can the emission values indicated for real operation be achieved.

- i** During trailer operation, the permissible gross vehicle weight is increased by 100 kg for vehicles registered as passenger vehicles. The maximum permissible rear axle load must be observed.

### Fitting the cover for trailer coupling

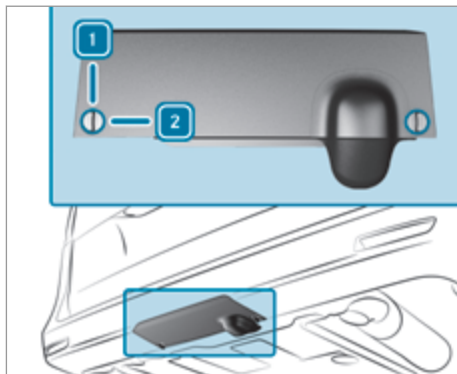

- ▶ Insert the cover flush into the recess on the rear bumper and press it upwards against the bumper covering at the latching points on the outside right and left.
- ▶ Turn fasteners from position **1** to position **2**.
- ▶ Ensure that the fasteners are fully engaged and firmly in position **2**.

### Attaching the ball neck

**!** **WARNING** Risk of accident and injury due to incorrectly installed and secured ball neck

If the ball neck is not engaged, it may become loose while the vehicle is in motion and endanger other road users.

- ▶ Engage the ball neck as described and ensure that the ball neck is securely installed.

**!** **WARNING** Danger of accident due to non-engaged ball coupling

If the ball coupling has not engaged, the trailer can become detached.

- ▶ Always engage the ball coupling as described and ensure that it is securely installed.

**Requirements:**

- The trailer hitch key is available.
- ▶ Note the number of the key that belongs to the ball neck of the trailer hitch. With this number, you will receive a replacement key at a Mercedes-Benz service centre.
- i** Depending on the vehicle equipment, the holder for the ball neck on the vehicle can be protected with a cover in the bumper.
- ▶ Release the two quick-release fasteners for the cover in the bumper and remove the cover (→ page 180).
  - ▶ Take the ball neck of the trailer hitch out of the stowage space on the right-hand side in the rear and stow the cover away.

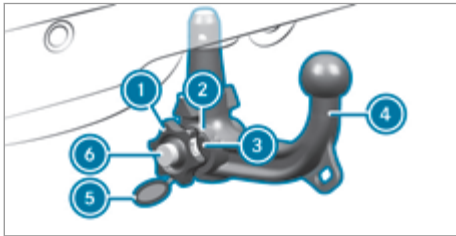

- ▶ Unlock lock **6** in handwheel **1** with the key. Red mark **3** on the handwheel must be aligned with green area **2** on ball neck **4** (fitting position).
  - ▶ If red mark **3** is not aligned with green area **2**, unlock lock **6** in handwheel **1** with the key.
  - ▶ Pull handwheel **1** outwards. Turn red mark **3** into green area **2** of ball neck **4** until handwheel **1** engages.
  - ▶ Slide ball neck **4** vertically into the holder until it audibly engages. The ball neck will lock automatically. Green mark **3** on handwheel **1** is aligned with green area **2** on ball neck **4**.
- Only if the green mark on the handwheel is aligned with the green area on the ball neck is the ball neck securely engaged.
- ▶ Lock lock **6** in handwheel **1** with the key.
  - ▶ Remove the key and place cap **5** on lock **6**. The ball neck is securely installed only if the ball neck can be locked and the key removed.
  - ▶ Store the trailer hitch key in a safe place, e.g. in the vehicle document wallet.

If you cannot remove the key, the ball neck may be dirty.

- ▶ Remove the ball neck (→ page 181) and clean it (→ page 235).

If you still cannot lock the ball neck after cleaning it, the trailer hitch is damaged.

- ▶ Remove the ball neck. Safe trailer operation is not guaranteed. The ball neck must no longer be used for trailer operation.
- ▶ Have the trailer hitch checked at a qualified specialist workshop.

**Removing the ball neck****Requirements:**

- The trailer hitch key is available.

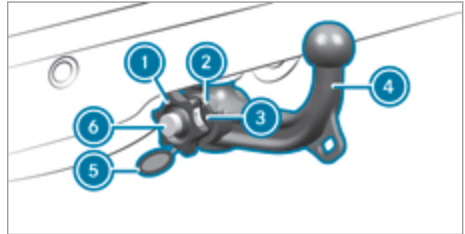

- ▶ Remove cap **5** from lock **6** in handwheel **1**.
  - ▶ Unlock lock **6** in handwheel **1** with the key.
  - ▶ Hold ball neck **4** in place.
  - ▶ Pull handwheel **1** outwards. Turn red mark **3** on handwheel **1** into green area **2** of ball neck **4** until handwheel **1** engages. Pay attention to the pictogram on handwheel **1**.
  - ▶ Pull ball neck **4** out downwards.
  - ▶ If the ball neck is dirty, clean it (→ page 235).
- i** Depending on the vehicle equipment, the holder for the ball neck on the vehicle can be protected with a cover in the bumper.
- ▶ Store the ball neck with the key inserted in the stowage space on the right-hand side in the rear and remove the cover for the ball neck holder.
  - ▶ Insert the cover in the lower section of the bumper and tighten the two quick-release fasteners for the cover (→ page 180).

## Coupling/uncoupling a trailer

### Requirements:

- The ball neck must be engaged in a securely locked position.

Trailers with 7-pin plugs can be connected to the vehicle using the following adapters:

- Adapter plug
- Adapter cable

### Coupling a trailer

**NOTE** Damage to the starter battery due to full discharge

Charging the trailer battery using the power supply of the trailer can damage the starter battery.

- ▶ Do not use the vehicle's power supply to charge the trailer battery.

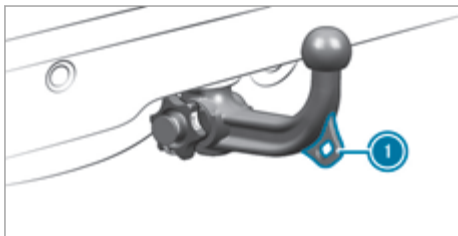

#### 1 Eyelet for breakaway cable

The eyelet on the ball neck is used exclusively for attaching the trailer breakaway cable. You must not attach a tow rope, a tow bar or anything similar to the eyelet. The eyelet has not been designed for such a load and may tear.

- ▶ Shift the transmission to position **P**.
- ▶ Apply the vehicle's parking brake.
- ▶ Close all the doors.
- ▶ Position the trailer on a level surface behind the vehicle.
- i** The height of the ball head will change depending on the vehicle's load. In this case, use a trailer with a height-adjustable drawbar.
- ▶ Couple up the trailer.



- ▶ **To install an adapter:** open the cover of the socket.
  - ▶ Insert plug 2 with tab 1 in the socket's groove 3.
  - ▶ Turn plug 2 clockwise as far as it will go.
  - ▶ Let the cover engage.
  - ▶ Attach the cable to the trailer with cable ties (only in the case of adapter cables).
  - ▶ Make sure that the cable is always slack for ease of movement during cornering.
  - ▶ Establish all electrical and other connections to the trailer. In the process, attach the trailer's breakaway cable to the eyelet on the ball neck.
  - ▶ Check that the trailer's lighting system works properly.
- A trailer is detected only if the electrical connection is established correctly and the lighting system is in working order. The function of other systems also depends on this, e.g. ESP®, PARKTRONIC, Active Parking Assist, Blind Spot Assist or Lane Keeping Assist.

Even if the trailer is connected correctly, a message may nevertheless appear on the instrument cluster display in the following cases:

- LEDs have been installed in the trailer's lighting system.
- The current has fallen below the trailer lighting system's minimum current (50 mA)
- i** You can connect accessories up to a maximum of 240 W to the permanent power supply.
- ▶ Remove objects or devices that prevent the trailer from rolling, e.g. chocks.
- ▶ Release the trailer's parking brake.

## Uncoupling a trailer

**⚠ WARNING** Risk of being crushed and becoming trapped when uncoupling a trailer

When uncoupling a trailer with an engaged inertia-activated brake, your hand may become trapped between the vehicle and the trailer drawbar.

- ▶ Do not uncouple trailers with an engaged overrun brake.

**! NOTE** Damage during uncoupling with an engaged overrun brake

The vehicle may be damaged if you uncouple with an engaged overrun brake.

- ▶ Do not uncouple trailers with an engaged overrun brake.

- ▶ Shift the transmission to position **P**.
- ▶ Apply the vehicle's parking brake.
- ▶ Close all the doors.
- ▶ Apply the trailer's parking brake.
- ▶ Further secure the trailer against rolling away with a wheel chock or similar object.
- ▶ Remove the trailer cables and safety chains.
- ▶ Uncouple the trailer.

## Overview of the instrument cluster

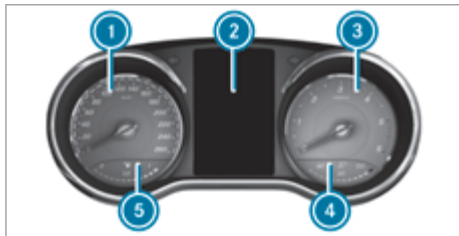

Instrument cluster (example)

- ① Speedometer
- ② Display
- ③ Rev counter
- ④ Coolant temperature display
- ⑤ Fuel level

### Speedometer

In vehicles with Active Distance Assist DISTRONIC, there are illuminated segments on the speedometer dial.

These segments show you what speed range is available:

- Variable limiter activated (→ page 160)  
The segments light up from the start of the scale to the selected limit speed.
- Active Distance Assist DISTRONIC switched on (→ page 163)  
One or two segments light up in the saved speed range.
- Active Distance Assist DISTRONIC detects a vehicle in front.  
The segments light up from the speed of the vehicle in front up to the saved speed.

You can show the speed as a digital speedometer on the display as well.

If you change your vehicle's wheel size, check its assignment to the wheel size group (→ page 263).

If the assignment changes without recoding the control units in the vehicle, the speedometer will not display the speed accurately. The current vehicle speed may then be higher than the speed shown by the speedometer. Driving and driving safety systems may then be operationally impaired or may detect a malfunction and switch themselves off.

In some countries, an audible signal will sound and/or a message will appear on the display when

the vehicle reaches the maximum speed permitted by law, e.g. at 120 km/h.

### Rev counter

**!** **NOTE** Engine damage due to maximum engine speed being exceeded

If the maximum permissible engine speed is exceeded, the engine may be damaged.

▶ Avoid driving in the red speed range (danger zone).

### Outside temperature display

You should pay special attention to road conditions when temperatures are around freezing point.

The outside temperature is shown on the instrument cluster display (→ page 186).

Changes in the outside temperature will be displayed after a short delay.

### Coolant temperature display

**!** **WARNING** Risk of burns when opening the bonnet

If you open the bonnet in the event of an overheated engine or fire in the engine compartment, the following situations may occur:

- You may come into contact with hot gases.
- You may come into contact with other escaping hot operating fluids.

▶ Before opening the bonnet, allow the engine to cool down.

▶ In the event of a fire in the engine compartment, keep the bonnet closed and call the fire service.

The coolant temperature display is located within the instrument cluster's rev counter.

During normal driving and if the coolant level is correct, the display is permitted to rise to 120°C.

## Overview and operation of the on-board computer

**!** **WARNING** Risk of distraction from information systems and communications equipment

If you operate information systems and communication devices integrated in the vehicle when driving, you could be distracted from the

traffic situation. This could also cause you to lose control of the vehicle.

- ▶ Only operate this equipment when the traffic situation permits.
- ▶ If you cannot be sure of this, stop the vehicle whilst paying attention to road and traffic conditions and operate the equipment with the vehicle stationary.

You must observe the legal requirements for the country in which you are currently driving when operating the on-board computer.

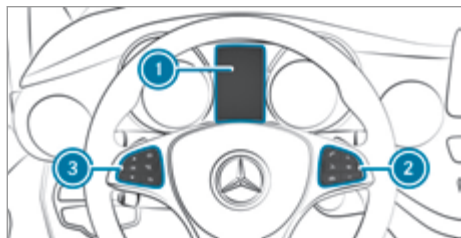

- ① Display
- ② Right control panel
- ③ Left control panel

When you switch the power supply on, the on-board computer will be activated.

Vehicles with manual transmission: if you remove the key, then quickly re-insert it and switch the power supply on, the on-board computer and the instrument cluster will not be activated.

You can control the displays and the settings on the on-board computer with the steering wheel buttons on the left ③ and right ② control panels.

### Steering-wheel buttons

#### Left control panel on the steering wheel



- Call up the main menu



#### Press briefly

- Scroll through lists
- Select menu or function
- In the **Radio** or **Media** menu, open the track or station list and select a station, audio track or video scene.
- In the **Telephone** menu, switch to the telephone book and select a name or a telephone number.



#### Press and hold

- Quickly scroll through all lists
- In the **Radio** or **Media** menu, use rapid scroll to select a station, audio track or video scene.
- In the **Telephone** menu with the telephone book open, start rapid scroll.



- In all menus, confirm the selected entry on the list or the display
- In the **Radio** or **Media** menu, open the list of available radio sources or media.
- In the **Telephone** menu, switch to the telephone book and start dialling the selected number.



- Switch off LINGUATRONIC



#### Press briefly

- Back
- Hide display messages
- In the **Radio** or **Media** menu, exit the track or station list
- Exit the telephone book or redial memory



#### Press and hold

- Call up the standard display in the **Trip** menu

### Right control panel on the steering wheel



- Make or accept a call
- Switch to the redial memory



- Reject or end a call
- Exit the telephone book or redial memory



- Adjust the volume



- Switch on LINGUATRONIC



- Switch sound on/off

### Overview of data shown on the instrument cluster display

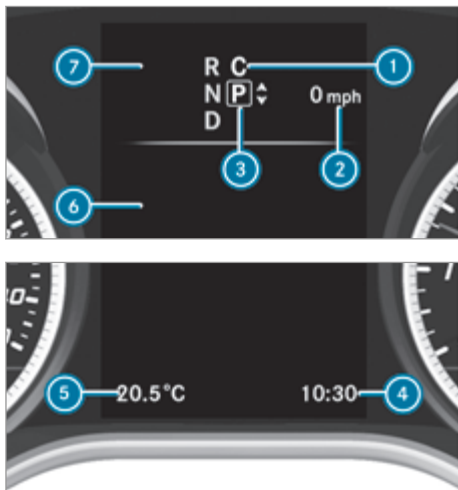







Display (example)

- ① Drive program (→ page 146)
- ② Additional speedometer
- ③ Transmission position (→ page 143)
- ④ Time
- ⑤ Outside temperature
- ⑥ Display section for display messages and menus
- ⑦ Status area

To call up the list of menus in display section ⑥, press the  steering-wheel button.



- ① You can switch additional speedometer ② on and off on the **Instrument cluster** submenu of the **Settings** menu.

The following displays may appear in status area ⑦ of the display:

- † Gearshift recommendation with manual transmission (→ page 143) or automatic transmission (→ page 146)
-  A door is not completely closed
-  PARKTRONIC (→ page 167)
-  Cruise control (→ page 159)
-  Limiter (→ page 159)
-  DSR (→ page 161)
-  Adaptive Highbeam Assist (→ page 112) or Adaptive Highbeam Assist Plus (→ page 113)

-  ECO start/stop function (→ page 141)

The following displays may also be shown in the footer of the display:

-  Active Parking Assist (→ page 172)
-  HOLD function (→ page 166)
- Maximum permitted speed of **120 km/h** exceeded (for certain countries only)
-  Rear window wiper switched on (→ page 120)

### Adjusting the instrument lighting

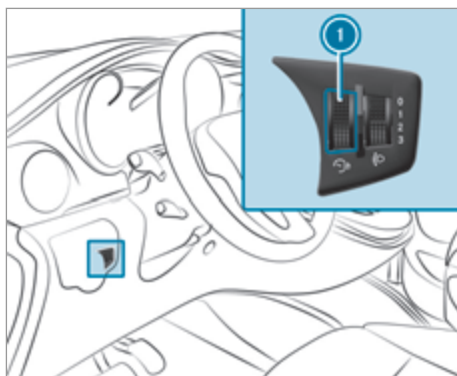

The displays on the instrument cluster are illuminated during the day. A dimming function is not possible in daylight.

The light sensor on the instrument cluster automatically controls the brightness of the display lighting.

When the light has been switched on, the brightness control is influenced by the ambient light. You can then adjust the brightness of the instrument lighting and the display lighting with controller ① as well.

- ▶ Turn controller ① up or down.

### Overview of menus on the on-board computer

Use the  steering-wheel button to call up the list of menus and select a menu.





You can find operating information in "Overview and operation of the on-board computer" (→ page 184).

Depending on the vehicle equipment, you can call up the following menus:

- **Trip** menu (→ page 187)
- **Navi** menu (navigation instructions) (→ page 188)
- **Radio** menu (→ page 190)
- **Media** menu (→ page 190)
- **Telephone** menu (→ page 191)
- **Assistance graphic** menu (→ page 187)
- **Service** menu (→ page 187)
- **Settings** menu (→ page 192)

## Menus and submenus

### Service menu

- ▶ Press the  button to call up the list of menus.
- ▶ Use the  or  button to select the **Service** menu.
- ▶ Press the  button to confirm.

You have the following options in the Service menu:

- Calling up display messages in the message memory (→ page 284).
- Checking the tyre pressure electronically or restarting the tyre pressure monitoring system (→ page 261).
- Checking the engine oil level electronically (→ page 228).
- Calling up the service due date (→ page 226)
- Displaying the AdBlue® fill level (in BlueTEC® vehicles).

### Assistant display menu





- ▶ Press the  button to call up the list of menus.

- ▶ With the  or  button, select the **Assistance graphic** menu.

- ▶ Press the  button to confirm.

The status of the following driving or driving safety systems can be displayed:

- Rear window wiper (→ page 120)
- Active Brake Assist (→ page 157)
- ATTENTION ASSIST (→ page 176)
- DSR (→ page 161)
- Traffic Sign Assist (→ page 177)
- Active Distance Assist DISTRONIC (→ page 164)
- Lane Keeping Assist (→ page 178)
- Blind Spot Assist (→ page 177)







- ▶ Press the  or  button to switch between the assistant display and the evaluation of ATTENTION ASSIST (→ page 175). The evaluation of ATTENTION ASSIST shows the length of journey since the last break and the calculated attention level.

### Trip menu

#### Displaying the range and current fuel consumption



- ① Approximate range
- ② Current fuel consumption
- ③ Recuperation display







- ▶ Press the  button to call up the list of menus.
- ▶ Use the  or  button to select the **Trip** menu.
- ▶ Press the  button.
- ▶ With the  or  button, select range and consumption.

If there is only a small amount of fuel left in the fuel tank, the display will show a vehicle being refuelled  instead of the approximate range ①.





Recuperation display  shows whether and, if so, how much kinetic energy is being converted to electrical energy while the vehicle is coasting. The recuperated energy is then stored in the starter battery.

### Displaying trip computer "From start" or "From reset"



- ▶ Press the  button to call up the list of menus.
- ▶ Use the  or  button to select the **Trip** menu.
- ▶ Press the  button.
- ▶ Press the  or  button to select the **From start** or **From reset** submenu.

The following values will be displayed:







-  Distance
-  Length of journey
-  Average speed
-  Average fuel consumption

The values on the **From start** submenu relate to those measured since the start of the journey. The values on the **From reset** submenu relate to those measured since the submenu was last reset.

The trip computer will automatically be reset under the following conditions:

- The vehicle has been switched off for longer than four hours (only **From start**).
- A time of 9999 hours has been exceeded.
- A distance of 99,999 km has been exceeded.







### Displaying the digital speedometer

- ▶ Press the  button to call up the list of menus.
- ▶ Use the  or  button to select the **Trip** menu.
- ▶ Press the  button.
- ▶ Select the digital speedometer using the  or  button.

### Resetting values

The values of the following functions can be reset:





- Trip distance
- "From start" trip computer
- "From reset" trip computer
- ECO display

- ▶ Press the  button to call up the list of menus.
- ▶ Use the  or  button to select the **Trip** menu.
- ▶ Press the  button.
- ▶ Use the  button to select **Yes** and confirm with the  button.

If the ECO display values are reset, the values in the "From start" trip computer will also be reset. If the values in the "From start" trip computer are reset, the ECO display values will also be reset.



### Navigation menu

In the **Navi** menu, the display shows navigation instructions from the multimedia system.

- ▶ Switch on the multimedia system.
- ▶ Press the  button to call up the list of menus.
- ▶ With the  or  button, select the **Navi** menu.
- ▶ Press the  button to confirm.

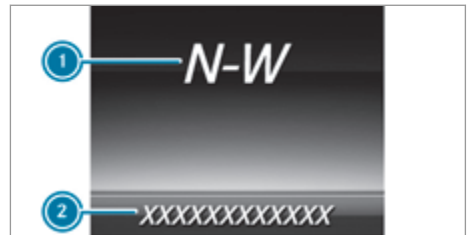
### Route guidance not active



-  Direction of travel
-  Name of current road

### Route guidance active



No change of direction announced

- ① Distance to the next destination
- ② Expected arrival time
- ③ Distance to the next change of direction
- ④ Name of current road

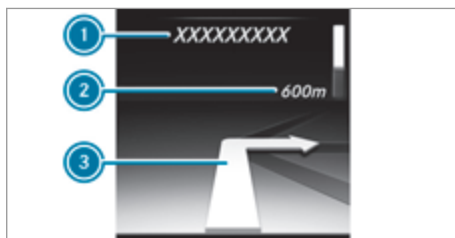

Change of direction without lane recommendation

- ① Road to which the change of direction leads
- ② Distance to the change of direction and distance indicator graphic
- ③ Change-of-direction symbol

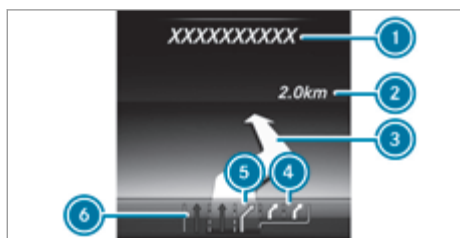

Change of direction announced with lane recommendation

- ① Road to which the change of direction leads
- ② Distance to the change of direction
- ③ Change-of-direction symbol
- ④ Recommended lane and new lane during a change of direction (white)
- ⑤ Possible lane (light grey)
- ⑥ Lane not recommended (dark grey)

If the digital map contains the corresponding data, lane recommendations for upcoming changes of direction can be displayed in the case of multi-lane roads. New lanes may be added during the change of direction.

Lane not recommended ⑥: in this lane, you will not be able to complete the next change of direction without changing lane.

Possible lane ⑤: in this lane will you be able to complete the next change of direction.

Recommended lane ④: in this lane, you will be able to complete both the next change of direction and the one after that.

When a change of direction is made, you will see distance indicator graphic ② in addition to change-of-direction symbol ③. This will reduce in size from bottom to top as you approach the announced change of direction. When the distance indicator runs out, the change of direction will begin.

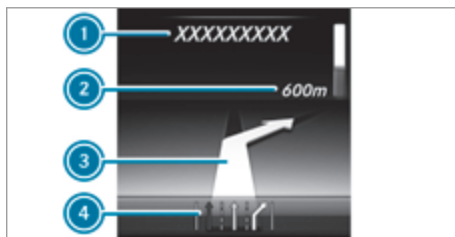

Change of direction with lane recommendation

- ① Road to which the change of direction leads
- ② Distance to the change of direction and distance indicator graphic
- ③ Change-of-direction symbol
- ④ Lane recommendation

The following additional navigation status displays are possible:

- **New route... or Calculating route...**

A new route is being calculated.

- **Road not mapped**

The vehicle's position is within the area of the digital map, but the road is not known, e.g. unpaved roads (off-road).

- **No route**

No route to the selected destination could be calculated.

-

You have reached the destination or an intermediate destination.

## Radio menu

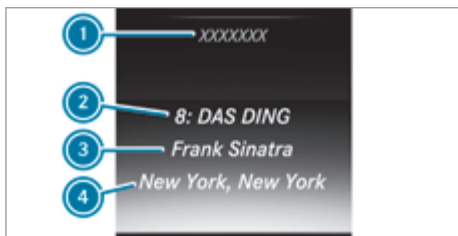

- ① Frequency band
- ② Channel with memory preset
- ③ Artist's name
- ④ Name of track

- ▶ Switch on the multimedia system.
- ▶ Press the button to call up the list of menus.
- ▶ Use the or button to select the **Radio** menu.
- ▶ Press the button to confirm. The display will show the station currently selected ②.
- ▶ **To open the station list:** briefly press the or button.
- ▶ **To select a station in the station list:** briefly press the or button.
- ▶ **To select a station in the station list with rapid scroll:** press and hold the or button.
- ▶ **To select a frequency band or station memory:** briefly press the button.
- ▶ Use the or button to select a frequency band or station memory.
- ▶ Press the button to confirm.
- ① You can find further information, e.g. about saving stations and about DAB radio mode (Digital Audio Broadcasting), in "Radio" (→ page 215).

## Media menu

- ▶ Switch on the multimedia system.
- ▶ Press the button to call up the list of menus.

- ▶ Use the or button to select the **Media** menu.
- ▶ Press the button to confirm.

## Changing the media source

You can change the media source and the playback type (audio, video or TV) in the **Media** menu.

- ▶ **To open/close the media source list:** briefly press the button. Depending on the vehicle equipment, the list will show the following media sources, for example:
  - Memory card (SD or SDHC)
  - Media register
  - USB storage devices
  - Bluetooth® audio equipment
- ① Observe the additional information on media support in "Media" (→ page 213).







## Operating data storage media



- ① Media source, e.g. the name of the USB flash drive
- ② Current track
- ③ Artist's name
- ④ Name of album
- ⑤ Folder name

Depending on the vehicle's equipment, you can play back audio files from different data storage media.

- ▶ **To select a data storage medium:** briefly press the button. The display will show the list of media sources.
- ▶ Press the or button to select a data storage medium.
- ▶ Press the button to confirm.
- ▶ **To open the track list:** briefly press the or button.











- ▶ **To select the next or previous track on the track list:** briefly press the  or  button.
- ▶ **To select a track on the track list with rapid scroll:** press and hold the  or  button until the desired track has been reached. If you press and hold the  or  button, the rapid scroll speed will increase after a short time. Not all audio players or data storage media support this function.

If the corresponding track information has been saved to the audio player or data storage medium, the display can show the following:

- Track number
- Track name
- Artist
- Album

The track information will not be displayed in AUX audio mode (auxiliary audio mode: external audio source connected).

### Operating video

- ▶ **To select a data storage medium:** briefly press the  button. The display will show the list of media sources.
- ▶ Press the  or  button to select a data storage medium.
- ▶ Press the  button to confirm.
- ▶ **To open the scene list:** briefly press the  or  button.
- ▶ **To select the next or previous scene on the scene list:** briefly press the  or  button.
- ▶ **To select a scene on the scene list with rapid scroll:** press and hold the  or  button until the desired scene has been reached.
- ▶ Press the  button to confirm.

### Telephone menu

**⚠ WARNING** Risk of distraction from operating integrated communication equipment while the vehicle is in motion





If you operate communication equipment integrated in the vehicle when driving, you could be distracted from the traffic situation. This could also cause you to lose control of the vehicle.

- ▶ Only operate this equipment when the traffic situation permits.
- ▶ If you cannot be sure of this, stop the vehicle whilst paying attention to road and traffic conditions and operate the equipment with the vehicle stationary.

When using the phone, you must observe the legal requirements for the country in which you are currently driving.

- ▶ Switch on the mobile phone (see the separate operating instructions from the manufacturer).
- ▶ Switch on the multimedia system.
- ▶ Insert the mobile phone into the mobile phone cradle.

or

- ▶ Establish a Bluetooth® connection with the multimedia system (→ page 212).
- ▶ Press the  button to call up the list of menus.
- ▶ Use the  or  button to select the **Telephone** menu.
- ▶ Press the  button to confirm.

The display will show one of the following messages:

- **Telephone ready** or name of the mobile phone network provider: the mobile phone has found a network and is ready to receive.
- **Telephone No service:** no network is available or the mobile phone is searching for a network.



You can obtain further information about suitable mobile phones and connecting mobile phones via Bluetooth® from a Mercedes-Benz service centre or on the internet under <https://www.mercedes-benz.com/connect>.

- ▶ **To accept a call:** press the  button.

If someone calls you when you are in the **Telephone** menu, a corresponding message will appear on the display.

- ▶ **To reject or end a call:** press the  button.

### Dialling a number from the telephone book

- ▶ Use the ,  or  button to switch to the telephone book.

- ▶ Use the  or  button to scroll through the names.



If you press and hold the button for longer than one second, the names in the telephone book will be displayed quickly one after the other.

or



- ▶ Press and hold the  or  button for longer than five seconds.

Rapid scrolling – the name that starts with the next letter or the previous letter in the alphabet is displayed.

Rapid scrolling will stop when you release the button or reach the end of the list.



- ▶ **If only one telephone number has been saved for a name:** press the  or  button to start dialling.

or

- ▶ **If several telephone numbers have been saved for a name:** press the  or  button to display the telephone numbers.

- ▶ Use the  or  button to select the telephone number.

- ▶ Press the  or  button to start dialling.

- ▶ **To exit the telephone book:** press the  or  button.

### Using redial

- ▶ Press the  button to switch to the redial memory.

- ▶ Use the  or  button to select the name or telephone number.

- ▶ Press the  or  button to start dialling.

- ▶ **To exit the redial memory:** press the  or  button.

### Settings menu

- ▶ Press the  button to call up the list of menus.

- ▶ Use the  or  button to select the **Settings** menu.

- ▶ Press the  button to confirm.

You have the following options on the **Settings** menu:

- Changing the settings for the driver assistance systems on the Assistance submenu
- Changing the settings for the exterior lighting on the Lights submenu

- Changing the display options on the Instrument cluster submenu

- Setting the permanent limiter on the Vehicle submenu

- Resetting the settings to factory settings

- ▶ Select the desired submenu and confirm your selection.

### Assistance submenu

- ▶ Select a driving or driver assistance system and configure a setting.

- Switching ESP® on/off (→ page 156).

- Switching Traffic Sign Assist on/off (→ page 177).

- Switching Active Brake Assist on/off (→ page 159).

- Switching Blind Spot Assist on/off (→ page 177)

- Adjusting ATTENTION ASSIST (→ page 176).

- Setting Lane Keeping Assist (→ page 179).

### Lights submenu

The following settings are possible on the Lights submenu:

- Switching the Intelligent Light System on/off (→ page 112)

- Switching between low beam for right- and left-side traffic (in vehicles with Intelligent Light System only)

- ▶ Use the  or  button to select the **Lights** submenu.

- ▶ Press the  button to confirm.

- ▶ **To switch between low beam for right- and left-side traffic:** use the  or  button to select **Dipped beams Setting for**.

The display will show the selected setting.

- ▶ Change the selected setting with the  button.

When you change the setting, the switchover will not take place until the next time the vehicle is stationary.

When you switch over the low beam for right- or left-side traffic, motorway mode and the enhanced fog light function may not be available. This deactivation will take place only if the setting for driving on the right or left is the opposite to your vehicle's national version.

You can have the low beam set for right- or left-side traffic at a qualified specialist workshop as well.

### Instrument cluster submenu

- ▶ Use the  or  button to select the **Instrument cluster** submenu.
- ▶ Press the  button to confirm.
- ▶ **To select the unit of measurement for distance:** use the  or  button to select the **Display unit Speed-/odometer** function. The display will show the selected setting **km** or **Miles**.
- ▶ Change the selected setting with the  button.
- ▶ **To switch the additional speedometer on/off:** use the  or  button to select **Addit. speedo**. The current selection will appear.
- ▶ Press the  button to change the setting.
- ⓘ The unit in the additional speedometer is always inverse to the unit of the speedometer.

### Vehicle submenu

- ▶ Use the  or  button to select the **Vehicle** submenu.
- ▶ Press the  button to confirm.
- ▶ **To set the permanent limiter:** use the  or  button to select **Limit speed (winter tyres)**. The display will show the current setting.
- ▶ **To change the setting:** press the  button.
- ▶ **To save the entry:** press the  button.
- ⓘ You can find further information in "Permanent limiter" (→ page 161).
- ▶ **To reset to factory settings:** use the  or  button to select the **Factory settings** submenu.
- ▶ Press the  button to confirm. The **Reset all settings?** function will be displayed.
- ▶ Use the  or  button to select **No** or **Yes**.
- ▶ Press the  button to confirm. If you selected **Yes** previously, the display will show a confirmation message.

For safety reasons, not all functions will be reset. The **Limit speed (winter tyres)** function for the per-

manent limiter can be adjusted only on the **Vehicle** submenu.

## Mercedes me calls

### Making a call via the overhead control panel

- ① Mercedes me calls are not possible in every country. Contact a Mercedes-Benz service centre to find out whether these functions are available in your country.

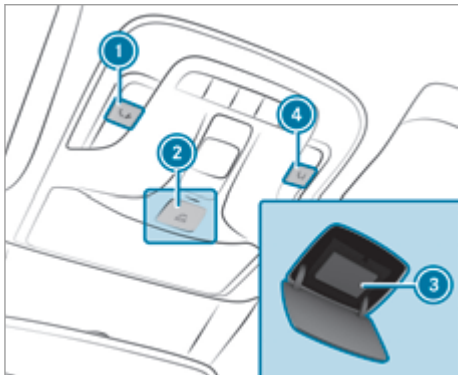

- ① Breakdown assistance call button
- ② Cover for button (SOS button)
- ③ button (SOS button)
- ④ Info call button

### Making a breakdown assistance call

- ▶ Press button ①.

### Making an emergency call

- ▶ Briefly press cover ② on button to open it.
- ▶ Press and hold button ③ for at least one second.

### Making an Info call

- ▶ Press button ④.

An emergency call can be initiated even if a breakdown assistance or Info call is active. This has priority over all other active calls.

### Information about service calls using the buttons in the overhead control panel

A call to the Mercedes-Benz customer centre via the info call button or breakdown call button in the overhead control panel has been made.

In the event of a breakdown, you will get support:

- A qualified Mercedes-Benz technician carries out repairs on site and/or the vehicle will be

towed to the nearest Mercedes-Benz service centre

You may be charged for these services.

You can find information on the following topics:

- Activation of Mercedes me connect
- Operating the vehicle
- Nearest Mercedes-Benz service centre
- Other products and services from Mercedes-Benz

Data is transmitted during the connection to the Mercedes-Benz Customer Centre (→ page 195).

### Calling the Mercedes-Benz Customer Centre using the multimedia system

#### Requirements:

- Access to a mobile phone network is available.
- The contract partner's mobile network coverage is available in the respective region.
- The ignition must be switched on so that vehicle data can be transferred automatically

Multimedia system:



- ▶ Call Mercedes me connect.

With your consent, the multimedia system sends the required vehicle data. The data transfer is shown in the media display.

Then, you can select a service and be connected to a contact at the Mercedes-Benz customer centre.

### Calling the Mercedes-Benz customer centre after automatic accident or breakdown detection

#### Requirements:

- The vehicle has detected an accident or breakdown situation.
- The vehicle is stationary.
- The hazard warning light is switched on.

- ① This function is not available in all countries.

The vehicle can detect accident or breakdown situations under limited conditions.

If an accident or breakdown is detected, the emergency guide shows safety instructions in the multimedia system display.

After quitting the emergency guide display on the multimedia system, a prompt appears asking

whether you wish to get support from the Mercedes-Benz customer centre.

▶ Select **Call**.

- After your agreement, or if the Mercedes me connect service "Accident and Breakdown Management" is active, the vehicle data is transferred automatically (→ page 197).
- The Mercedes-Benz customer centre will take your call and organise breakdown and accident assistance.

You may be charged for these services.

- ⓘ Depending on the severity of the accident, an automatic emergency call can be made. This has priority over all other active calls.
- ⓘ In addition, if the "Telediagnosis" Mercedes me connect service is active, a similar query may appear at a later time in the event of a breakdown. If you are already in contact with the Mercedes-Benz customer centre or have received help, this query can be ignored or rejected.
- ⓘ If you answer the prompt for support from the Mercedes-Benz customer centre with **Later** the message will disappear and reappear at a later time.  
The query triggered by the "Telediagnosis" Mercedes me connect service can either be confirmed or rejected. After rejection, it is no longer displayed.

### Arranging a service appointment via Mercedes me call

If you have activated the maintenance management service, relevant vehicle data is transferred automatically to the Mercedes-Benz Customer Centre. You will then receive individual recommendations regarding the maintenance of your vehicle.

Regardless of whether you have consented to the maintenance management service, the multimedia system reminds you after a certain amount of time that a service is due. A prompt appears asking if you would like to make an appointment.

▶ **To arrange a service appointment:** select **Call**. After your confirmation, the vehicle data is sent and the Mercedes-Benz customer centre deals with your appointment. The information is then sent to your desired service outlet.

They will contact you to confirm the appointment and, if necessary, to discuss the details.

- ⓘ If you select **Later** after the service message appears, the message is hidden and reappears at a later time.

### Consenting to data transfer for a Mercedes me call

#### Requirements:

- There is an active Mercedes me call via the multimedia system or the buttons in the overhead control panel (→ page 194).
- ⓘ The prompt to confirm data transfer does not appear in all countries.

If the Accident and Breakdown Management services are not activated on Mercedes me, the following message appears **Do you want to transmit vehicle data and the vehicle's position to the Mercedes-Benz Customer Centre in order to improve the processing of your request?**

▶ Select **Yes**.

Relevant identification data is transmitted automatically.

More information on Mercedes me: <https://www.mercedes.me>

### Transferred data during a Mercedes me call

When you make a service call via Mercedes me, data is transmitted. This enables targeted advice and smooth service.

The following requirements must be met for the data transfer:

- The vehicle is switched on.
- The necessary data transmission technology is supported by the mobile network provider.
- A sufficient mobile phone connection quality is provided.

Multi-stage transmission depends on the following factors:

- Reason for the initiation of the call
- Available mobile radio transmission technology
- Activated Mercedes me connect services
- Selected service in the voice dialogue system

- ⓘ A request for consent to data transmission is only made if the corresponding Mercedes me connect service has not been activated.

### Data transmission when Mercedes me connect services are not activated

If no Mercedes me connect services are activated and the data protection query has been confirmed, the following data will be transferred:

- Vehicle identification number
- Time of the call
- Reason for the initiation of the call
- Confirmation of the data protection prompt
- Vehicle country code
- Set language for the multimedia system
- Call number of the communication platform installed in the vehicle

If a call is made for a service appointment via the service reminder, the following data is also transmitted:

- Current mileage and maintenance data

If a call was made via the multimedia system after automatic accident or breakdown detection, the following data is also transmitted:

- Current mileage and maintenance data
- Current vehicle location

If the Accident and Breakdown Management selection has been made via the voice dialogue system and no service has been activated, but the data protection query has been confirmed, the following data can be additionally requested from the vehicle by the Mercedes-Benz customer centre:

- Current vehicle location

If the data protection request has been declined, the following data will be transferred to enable targeted advice and a smooth service:

- Reason for the initiation of the call
- Rejection of the data protection prompt
- Vehicle country code
- Set language for the multimedia system
- Call number of the communication platform installed in the vehicle

### Data transmission when Mercedes me connect services are activated

Only in the second step, only for the respective activated services, further case-specific data is transmitted in order to enable an optimal service.

An overview of the transmitted data can be found in the respective terms of use for Mercedes me

connect services. These can be obtained in the Mercedes me portal: <https://me.secure.mercedes-benz.com>

### Data processing

The data transmitted as part of the call will be deleted from the transmitting systems once the call has been completed, provided they are not used for other activated Mercedes me connect services.

The case-related data will be processed and stored in the Mercedes-Benz customer centre and, if necessary for case processing, forwarded to the service partners commissioned by the Mercedes-Benz customer centre. Please refer to the data protection information on the Mercedes me website at <https://www.mercedes.me> or in the recorded message immediately after the call to the Mercedes-Benz customer centre has been set up.

 The recorded message is not available in every country.

## Mercedes me connect

### Information about Mercedes me connect

 Mercedes me connect or individual Mercedes me connect services are not available in every country. Contact a Mercedes-Benz service centre to find out whether these functions are available in your country.

Mercedes me connect consists of a variety of services.

Using the multimedia system or the overhead control panel, you can use the following services, for example:

- Accident and Breakdown Management (Breakdown call button or the situation-dependent display in the multimedia system)
- Accident and Breakdown Management (breakdown button)
- Mercedes-Benz emergency call system (automatic emergency call and SOS button)

Mercedes me connect Accident and Breakdown Management and the Mercedes-Benz emergency call centre are available to you around the clock.

You will find the breakdown call button and the SOS button in the vehicle's overhead control panel (→ page 194).

You can also call the Mercedes-Benz customer centre using the multimedia system (→ page 194).

Please note that Mercedes me connect is a Mercedes-Benz service. In emergencies, call the national emergency services first using the standard national emergency service phone numbers. In emergencies, you can also use the Mercedes-Benz emergency call system (→ page 239).

Observe the conditions of use for Mercedes me connect and other services. These can be obtained in the Mercedes me portal: <https://me.secure.mercedes-benz.com>

Further information about Mercedes me connect, the provided service scope and operation: [https://moba.i.daimler.com/markets/ece-row/baix/cars/connectme/en\\_GB/#emotions/Startseite.html](https://moba.i.daimler.com/markets/ece-row/baix/cars/connectme/en_GB/#emotions/Startseite.html)

### Information on Mercedes me connect Accident and Breakdown Management

The Accident and Breakdown Management can, amongst others, include the following functions:

- Supplement to the Mercedes-Benz emergency call system (→ page 239)

If necessary, the contact person at the Mercedes-Benz emergency call centre forwards the call to Mercedes me connect Accident and Breakdown Management. However, call forwarding is not possible in all countries.

- Breakdown assistance on location by a technician and/or towing away of the vehicle to the nearest Mercedes-Benz Service Centre  
You may be charged for these services.
- Supplement to the emergency guide after automatic accident or breakdown detection (→ page 194)

In the event of a breakdown or accident, extended vehicle data is sent, enabling optimum support from the Mercedes-Benz customer centre and the appointed service partner or breakdown mechanic.

- Supplement to the Mercedes me connect telediagnosics service

With the telediagnosics function, the service provider records certain wear and failure messages, insofar as these can be clearly interpreted and are available by monitoring diagnosable components.

If your vehicle detects a breakdown or impending breakdown, you may be prompted via the multimedia system to contact the Mercedes-Benz customer centre for further assistance.

This prompt in the multimedia system only appears when the vehicle is stationary.

- ⓘ These services are subject to technical restrictions such as mobile coverage and mobile network quality and the interpretability of the transmitted data in the processing systems. Under certain circumstances, this may result in delays or omission of the message in the multimedia system.

Further information about Mercedes me connect services can be obtained in the Mercedes me Portal: <https://me.secure.mercedes-benz.com>

### Transmitted data with the Mercedes me connect call services

The data transferred during the Mercedes me connect call depends on:

- The reason for the initiation of the call
- The service selected in the voice dialogue system
- The activated Mercedes me connect services

You can find out which data is transferred during the services in the currently valid Mercedes me connect terms of use and the data protection information for Mercedes me connect. You can find these in your Mercedes me user account.

## Mercedes me and apps

### Information about Mercedes me

When you log in with a user account to the Mercedes me Portal, then services and offers from Mercedes-Benz will be available to you.

Availability is country-dependent.

For more information consult a Mercedes-Benz service centre or visit the Mercedes me portal: <https://me.secure.mercedes-benz.com>

- ⓘ Make sure that you always keep the Mercedes me apps up to date.

### Calling up a Mercedes me user account

Multimedia system:

→  **Mercedes me & Apps**

### Vehicle is linked to user account

- ▶ Select **Mercedes me**.  
Information about the connected user account appears.

### Vehicle is not yet linked to user account

- ▶ Select [Mercedes me](#).
- ▶ Follow the instructions on the media display to create a user account and link the vehicle to it.
- ⓘ If the Mercedes me app is available on a mobile phone, the vehicle link can be made via the displayed QR code.



### Calling up Mercedes me services

---

#### Requirements:

- The vehicle is connected with the user account.

Multimedia system:

- ▶   ▶▶ [Mercedes me & Apps](#)
- ▶ Select [Services](#).  
You will be shown the Mercedes me services that you have already purchased and those that you can also still purchase within the various categories.  
To activate or deactivate the services, log in to the Mercedes me Portal with your user account.



### Removing the link between the user account and the vehicle

---

#### Requirements:

- The user profile of the user account that was first linked to the vehicle is selected.
- The profile is synchronised.
- A PIN has been saved.

Multimedia system:

- ▶   ▶▶ [Mercedes me & Apps](#)
- ▶▶ [Mercedes me](#)
- ▶ Select [Delete vehicle assignment](#).
- ▶ Enter the PIN of the linked user account.
- ⓘ Only the user whose user account was linked to the vehicle first can remove the link between all user accounts and the vehicle.

## Overview and operation

### Notes on MBUX multimedia system

**⚠ WARNING** Risk of distraction from information systems and communications equipment

If you operate information systems and communication devices integrated in the vehicle when driving, you could be distracted from the traffic situation. This could also cause you to lose control of the vehicle.

- ▶ Only operate this equipment when the traffic situation permits.
- ▶ If you cannot be sure of this, stop the vehicle whilst paying attention to road and traffic conditions and operate the equipment with the vehicle stationary.

You must observe the legal requirements for the country in which you are currently driving when operating the multimedia system. Depending on the equipment, the range of functions and product designation of your MBUX multimedia system may differ from the description and illustrations in the Owner's Manual. For example, the LINGUATRONIC and navigation system functions are not available in all equipment variants.

### Overview of the MBUX multimedia system

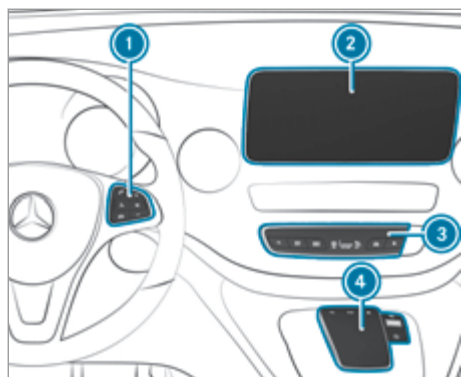

- ① Control panel for multimedia system
- ② Media display with touch functionality
- ③ Operating strip, calls up applications
- ④ Touchpad and controls for the multimedia system

- ① You can find further information about operation as well as about applications and services in the Digital Owner's Manual.

There are two USB ports in the centre console storage compartment.

The USB port with the  symbol facilitates the connection of the mobile phone with the multimedia system using a suitable cable. This will enable you to use the functions of the mobile phone via Apple CarPlay® or Android Auto.

### Notes on the media display

Observe the notes on caring for the interior (→ page 236).

**Automatic temperature-controlled switch-off feature:** if the temperature is too high, the brightness is initially reduced automatically. The media display may then switch off completely for a while.

- ① If you are wearing polarised sunglasses, it may be difficult to read the media display.

### Anti-theft protection

This device is equipped with technical provisions to protect it against theft. More detailed information about anti-theft protection can be obtained at a qualified specialist workshop.

## Home screen overview

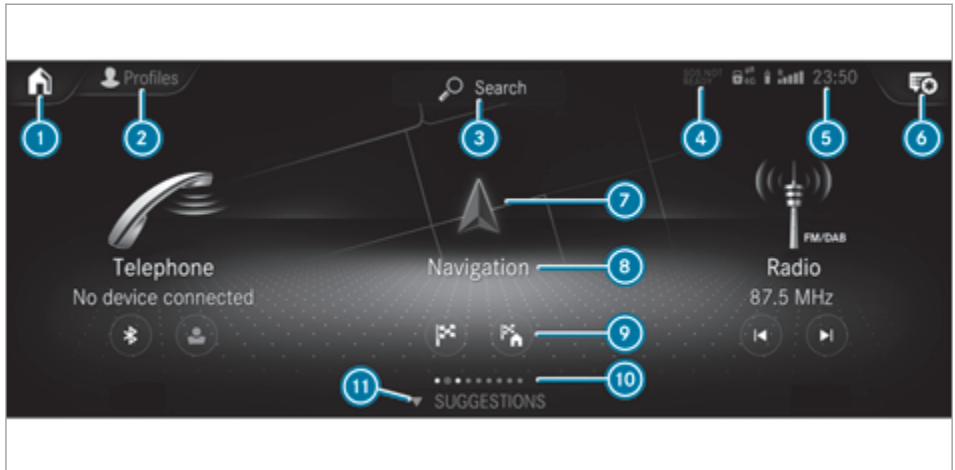

- ① On the home screen: displays the first three applications  
In other displays: calls up the home screen
- ② Calls up the profile
- ③ Calls up the global search
- ④ SOS NOT READY display only when the Mercedes-Benz emergency call system is not available
- ⑤ Displays, for example network display, battery status of the mobile phone connected, signal strength of the mobile phone network, time
- ⑥ Calls up the Notifications Centre  
The star indicates new notifications.
- ⑦ Calls up an application using the symbol
- ⑧ Name of the application, beneath the current selection or information
- ⑨ Quick-access (in the example: calls up destination entry and enters the destination address for home)
- ⑩ Number of applications and currently selected display area
- ⑪ Calls up **SUGGESTIONS** and **FAVOURITES**

## Operating the MBUX multimedia system

### Using the steering wheel buttons

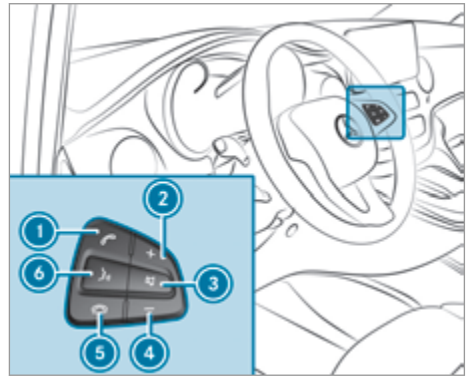

- ① Makes or accepts a call
- ② Increases the volume
- ③ Mutes
- ④ Reduces volume
- ⑤ Rejects or ends a call
- ⑥ Switches on LINGUATRONIC

▶ Press one of the buttons.

### Using the touchscreen

- ▶ **To navigate in menus:** swipe up, down, left or right.
- ▶ **To select an entry:** tap on the entry.

- ▶ **To enter characters with the keyboard:** tap on a button.
- ▶ **To use handwriting to enter characters:** write the character with one finger on the touchscreen.
- ▶ **To zoom in and out of the map:** move two fingers together or apart.
- ▶ **To enlarge or reduce the size of a section of a website:** move two fingers together or apart.
- ▶ **To call up a global menu in the applications:** touch the touchscreen and hold until the **OPTIONS** menu appears.

### On the touchpad

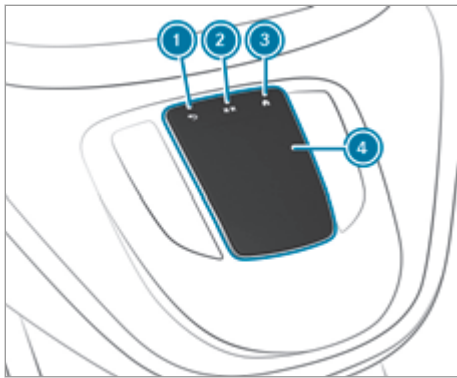

- ① Returns to the previous display
  - ② Calls up the control menu of the last active audio source
  - ③ Shows the home screen and calls up applications
  - ④ Touchpad
- ▶ **To navigate in menus:** swipe up, down, left or right.
  - ▶ **To select an entry:** press on the entry.
  - ▶ **To enter a character:** enter a character using the keypad.
- or
- ▶ Write a character on the touchpad.
  - ▶ **To move the digital map:** swipe in any direction.

### Calling up applications using buttons

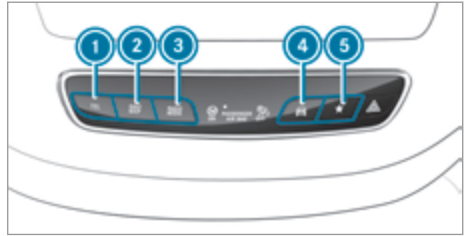

- ① Calls up the telephone
  - ② Calls up the navigation or map
  - ③ Pressing repeatedly calls up the desired audio source
  - ④ Sets vehicle functions
  - ⑤ Calls up favourites
- ▶ Press one of the buttons.

### Function of LINGUATRONIC

If you use the voice control system in an emergency your voice can change and your telephone call, e.g. an emergency call, can thereby be unnecessarily delayed.

Familiarise yourself with the voice control system functions before starting the journey.

With LINGUATRONIC, various applications of the MBUX multimedia system can be operated by voice input. LINGUATRONIC is operational approximately thirty seconds after the vehicle is switched on and is available from the driver's and front passenger's seat.

The following applications of the multimedia system can be operated:

- Navigation
- Telephone
- Radio
- Media player
- Messages
- Vehicle functions

### Starting LINGUATRONIC

- ▶ Press the rocker switch up on the multi-function steering wheel. You can say a voice command after the acoustic signal.

## Information on profiles, suggestions and favourites

Using the multimedia system up to seven profiles can be created in the vehicle.

Profiles store your personal vehicle settings and settings for the multimedia system.

If the vehicle is used by several drivers, the driver can select their profile before the journey, without changing the settings of other drivers.

The following settings are saved in your profile, for example:

- Radio (including station list)
- Last destinations
- Favourites and suggestions

The vehicle can learn the habits of the driver. It then offers suggestions for the most likely navigation destinations, media sources, radio stations or contacts. The requirements for that are the selection of a profile, your consent to the recording of data and sufficient collected data.

Favourites are quick accesses to frequently used applications. Favourites can be selected from categories or added directly in an application.

## Configuring profiles and suggestions

Multimedia system:



### Creating a new profile

- ▶ Select **Create profile**.
- ▶ Select an avatar.
- ▶ Enter the name and confirm with .
- ▶ Select **Continue** .
- ▶ Select **Current settings**.
- ▶ Select **Save**.
- ▶ Activate Bluetooth® and select **Connect phone**, to connect a mobile phone with the user profile.
- ▶ Select **Finished**.

### Selecting profile options

- ▶ Select for a profile.
- The following functions are available:
- Resetting or deleting a profile
  - Resetting favourites
  - Configuring suggestions

## Configuring suggestions

- ▶ Select for a profile.
- ▶ Select **Suggestions settings**.
- ▶ Switch **Allow destination suggestions**, **Allow music suggestions** and **Allow contact suggestions** on or off.
- ▶ **To deactivate the learn function for one day:** activate **Deact. learn. for 24h**.  
For 24 hours no new actions will be trained and no data recorded for the active profile. Suggestions will continue to be shown.  
Example: if the option is switched on and a route to a new destination has been calculated, this destination would not be taken into account for the learn function.

## System settings

### Overview of the system settings menu

In the system settings menu, you can make settings in the following menus and control elements:

- Display
- Control elements:
  - Keyboard language and handwriting recognition
  - Sensitivity of the Touch Controls
- LINGUATRONIC
- Sound:
  - Entertainment
  - Navigation and traffic announcements
  - Telephone
  - Voice amplification to the rear
- Connectivity:
  - Transmission of the vehicle location
  - Wi-Fi, Bluetooth®, NFC
- Time & date
- Language
- Units for distance
- Software updates
- Data import and data export
- PIN protection
- System Reset

## Information on important system updates

Important system updates may be necessary for the security of your multimedia system's data. Install these updates, or else the security of your multimedia system cannot be ensured.

A system update consists of three steps:

- Downloading or copying of the data required for installation
  - Installation of the downloaded system update
  - Activating the downloaded system update by restarting the system
- i** An Internet connection is required for online updates. For automatic online updates, your vehicle must have a permanently installed communication module.
- i** You can start the software update manually via the system settings. If automatic software updates are activated, the system updates will be downloaded automatically. Settings for automatic software updates can also be made in the system settings.

The multimedia system provides a corresponding message when a system update is available.

You have the following selection options:

- **Download**  
The system update will be downloaded in the background.
- **Details**  
Information about the pending system update is displayed.
- **Later**  
The system update can be downloaded manually at a later time.

## Deep system updates

Deep system updates access vehicle or system settings and can therefore only be carried out when the vehicle is stationary and the vehicle is switched off.

When the download of a deep system update is complete and the downloaded system update is ready for installation, you will be notified, for example, after the vehicle is switched on again.

- i** Park the vehicle safely in a suitable location before starting the installation.

Requirements for the installation:

- The vehicle is switched off.
- Notes and warnings have been read and accepted.
- The electric parking brake has been applied.

If all requirements are met, the downloaded system update is installed. The multimedia system cannot be operated while the downloaded system update is being installed and vehicle functions are restricted.

If errors should occur during the installation, the multimedia system automatically attempts to restore the previous version. If restoration of the previous version is not possible, a symbol appears on the media display. Consult a qualified specialist workshop to resolve the problem.

## Setting up a WLAN hotspot

Requirements:

- **To set up the Wi-Fi connection of the multimedia system with external hotspots:** there is no communication module installed.
- The device to be connected supports at least one of the types of connection described.

Multimedia system:





 Settings >> System >> Wi-Fi & Bluetooth

## Activating/deactivating Wi-Fi



-  Select **Wi-Fi**.

## Connecting the multimedia system to an external hotspot via Wi-Fi

- i** The connection procedure may differ depending on the device. Follow the instructions that are shown in the display. Further information can be found in the manufacturer's operating instructions.

-  Select **Internet settings**.
-  Select **Connect via Wi-Fi**.
-  Select **Add hotspot**.
-  Select the type of connection to be established on the multimedia system and on the device to be connected.

## Connecting using a security key

-  Select the options  of the desired Wi-Fi network.
-  Select **Connect using security key**.

- ▶ Have the security key displayed on the device to be connected (see the manufacturer's operating instructions).
- ▶ Enter this security key on the multimedia system.
- ▶ Confirm the entry with **OK**.

### Activating automatic connection

- ▶ Select **Connect via Wi-Fi**.
- ▶ Select the options  of the desired Wi-Fi network.
- ▶ Activate **Permanent Internet connection**.

### Connecting with a known Wi-Fi

- ▶ Select **Connect via Wi-Fi**.
- ▶ Select a Wi-Fi network.  
The connection is established again.

### Configuring the multimedia system as a WLAN hotspot for external devices

The type of connection established depends on the device to be connected. The function must be supported by the multimedia system and by the device to be connected.

- ▶ Select **Vehicle hotspot**.
- ▶ Select **Connect device to vehicle hotspot**.
- ▶ Select the type of connection to be established on the multimedia system and on the device to be connected.

### Connecting using a security key

- ▶ Select **Connect device to vehicle hotspot**.  
A security key is displayed.
- ▶ Select the vehicle from the device to be connected. The vehicle is displayed with the **DIRECT-MBUX XXXXX** network name.
- ▶ Enter the security key which is shown in the media display on the device to be connected.
- ▶ Confirm the entry.

### Connecting using NFC

- ▶ Select **Connect via NFC**.
- ▶ Activate NFC on the mobile device (see the manufacturer's operating instructions).
- ▶ Hold the device to be connected at the vehicle's NFC interface.
- ▶ Select **Finished**.  
The mobile device is now connected to the multimedia system hotspot via NFC.

### Generating a new security key

- ▶ Select **Vehicle hotspot**.
- ▶ Select **Generate security key**.
- ▶ Select **New security key**.  
A connection will be established with the newly created security key.
- ▶ **To save a security key:** select **Save**.  
When a new security key is saved, all existing Wi-Fi connections are then disconnected. If the Wi-Fi connections are being re-established, the new security key must be entered.

### System language

#### Notes on the system language

This function allows you to determine the language for the menu displays and the navigation messages. The selected language affects the characters available for entry. The navigation announcements are not available in all languages. If a language is not available, the navigation announcements will be in English.

#### Setting the system language

Multimedia system:

  **Settings**  **System**  
 **Language**

- ▶ Set the language.
- ▶  If you are using Arabic map data, the text information can also be shown in Arabic on the navigation map. To do so, select **العربية** as the language from the language list. Navigation announcements are then also made in Arabic.

### Resetting the multimedia system (reset function)

 **WARNING** Risk of accidents due to failure of multimedia display functions

While the multimedia system is being reset, its functions such as the reversing camera are not available.

- ▶ Only reset the multimedia system when the vehicle is stationary.

Multimedia system:

  **Settings**  **System**  **Reset**

Personal data is deleted, for example:

- Station presets
- Connected mobile phones
- Individual user profiles

- ❗ The guest profile is reset when the settings are restored to the factory settings.

A query appears again asking if the system should really be reset.

- ▶ Select **Yes**.

If PIN protection is activated, a prompt appears asking if you also wish to restore this to the factory settings during a reset.

- ▶ Variant 1: select **Yes**.
- ▶ Enter the current PIN.  
The PIN is reset.
- ▶ Variant 2: select **No**.  
The current PIN stays the same after resetting.

- ❗ If you have forgotten your PIN, a Mercedes-Benz service centre can deactivate the PIN protection for you.

A prompt appears again asking whether you really wish to reset.

- ▶ Select **Yes**.  
The multimedia system is reset to the factory settings.

### Resetting using a button

- ▶ Press both the **TEL** and **☆** buttons at the same time until the multimedia system restarts (at least 15 seconds).  
The multimedia system is restarted. No data is deleted during this process.

## Navigation

### Switching on navigation

Multimedia system:

- ▶  ▶ **Navigation**

- ▶ Alternatively: press the  button.  
The map shows the current vehicle location.  
The navigation menu is shown.  
The navigation menu is hidden if route guidance is active.
- ▶ **To show:** tap on the touchscreen.
- ▶ **To hide:** the menu is hidden automatically.

## Navigation overview



Example: digital map with navigation menu

- ① To enter a POI or address and additional destination entry options
  - ② To interrupt route guidance (if route guidance is active)
  - ③ To repeat a navigation announcement and switch navigation announcements on or off
  - ④ To call up the **ON ROUTE** menu
    - To show **Route overview**
    - To select **Alternative routes**
    - **Report traffic incident** (Car-to-X)
    - To call up the **TRAFFIC** menu
    - To show **Traffic announcements**
    - To show **Area announcements**
    - To show **Live Traffic Subscription Info**
    - To show **Route list**
  - ⑤ To call up the **POSITION** menu
    - **Store position**
    - To show **Compass**
    - To show **Qibla** (available in selected countries)
  - ⑤ Quick-access and settings
    - To show **Traffic**
    - To show **Parking**
    - To show **Motorway information**
    - Via **Advanced** options to use **View, Announcements** and **Route**
- ① Some options are not available in all countries.

## Entering a destination

Multimedia system:

Navigation >> Where to?



- ① Country in which the vehicle is located
- ② Entering a POI or address  
Underneath: Multimedia system suggestions during destination entry  
During input: delete the entry with [X].
- ③ List with additional destination entry options  
During destination entry: select search result
- ④ Deletes entered character
- ⑤ [OK] Confirms an entry
- ⑥ Calls up handwriting recognition
- ⑦ Enters a space
- ⑧ Activates voice input
- ⑨ Sets the written language
- ⑩ Switches to numbers, special characters and symbols
- ⑪ Switches to upper-case or lower-case letters  
▶ Enter the destination in ②. The entries can be made in any order.

The following entries can be made, for example:

- Town, street, house number
- Street, town
- Postcode
- POI name or POI category
- Contact name
- ▶ Select a search result in list ③.
- ▶ Calculate the route (→ page 208).

- ① You can find further information about destination entry, e.g. 3 word addresses, in the Digital Owner's Manual.

### Changing the country

- ▶ Select the country indicator in ①.
- ▶ Enter the country indicator.
- ▶ Select the country in ③.

### Using online search

- ① Requirements: the media display shows an Internet connection with a double-arrow symbol in the status line.
- ① Online search is not available in all countries.  
Destination entry uses online map services. If the on-board search finds no suitable destinations or if you change countries, the online search is available.

For the destination you can enter an address, a POI or a three-word address.

- ▶ Select country indicator ①.
- ▶ Select the provider for the online service from the countries list.
- ▶ Enter the destination in ②.  
The search results are displayed.
- ▶ Select the destination in list ③.  
The detailed view for the route is displayed.

or

- ▶ Enter the destination in ②.  
The search results are displayed.
- ▶ Select the destination in list ③.  
The detailed view for the route is displayed.

## Calculating a route and using settings for route guidance





### Requirements:

- The destination has been entered.
- The destination address is shown.
- **For the commuter route:** you have created a profile (→ page 202).
- The **Allow destination suggestions** option is switched on.
- The **Activate commuter route** option is switched on.
- The multimedia system has gathered sufficient data in order to show destination suggestions.
- Routes have been learned for these destination suggestions.

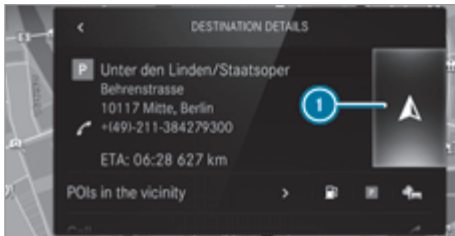

Multimedia system:

▶  ▶ Navigation



- ①  No route yet
-  A route has been mapped
- ▶ Select .  
The route to the destination is calculated.  
Route guidance begins.
- or
- ▶ Select .
- ▶ Select **Set as intermediate dest.**  
The destination address is set as the next intermediate destination.
- or
- ▶ Select **Start new route guidance.**  
The destination address is set as the new destination. The previous destination and the intermediate destinations are deleted. Route guidance to the new destination begins.

## Selecting route settings

- ▶ Select .
- ▶ Select **Advanced.**
- ▶ Select **Route.**
- ▶ Select the route type.
- ▶ Take traffic information into consideration with **Dynamic route guidance** .
- ▶ Selecting route options with **Avoid options.**
- ▶ Activate **Alternative routes.**  
Alternative routes are calculated for every route.
- ▶ Activate **Activate commuter route.**  
If the requirements for a commuter route are met, the multimedia system automatically detects that the vehicle is on a commuter route. Route guidance begins without voice output.

## Using map functions

Multimedia system:

▶  ▶ Navigation

### Enlarging the map scale

- ▶ When the map is shown, tap twice quickly with one finger on the media display.

or

- ▶ Move two fingers apart on the media display.

### Reducing the map scale

- ▶ Tap with two fingers on the media display.

or

- ▶ Move two fingers together on the media display.

### Moving the map

- ▶ Move one finger in any direction on the touchscreen.
- ▶ **To reset the map to the current vehicle position:** press  briefly.

### Selecting map orientation

- ▶ Press the  compass symbol repeatedly on the map.  
The view changes in the sequence **3D, 2D heading up to 2D north up.**

### Switching motorway information on or off

- ▶ Select .
- ▶ Activate or deactivate **Motorway information.**

## Using services

### Requirements:

- There is an Internet connection.
- Mercedes me connect is available.
- You have set up a user account in the Mercedes me Portal.
- The vehicle is connected to a user account and you have accepted the conditions of use for the service.

Further information can be found at: <https://www.mercedes.me>

- The service is available and has been activated.

Multimedia system:

   [Navigation](#)

### Displaying the traffic situation with Live Traffic Information

- ▶ Select .
- ▶ Activate [Traffic](#).
- ▶ Select [Advanced](#).
- ▶ Select [View](#).
- ▶ Select [Map elements](#).
- ▶ Switch on [Traffic incidents](#), [Free-flowing traffic](#) and [Delay](#).

If traffic information has been received, then traffic incidents such as roadworks, road blocks, local area reports (e.g. fog) and warning messages are displayed.

The traffic delay is displayed for the current route. Traffic delays lasting a period of one minute or longer are taken into consideration.

### Displaying hazard warnings with Car-to-X-Communication

If hazard warnings are available these are shown as symbols on the map. The display depends on the settings for the [Traffic](#) and [Traffic incidents](#) options.

- ▶ Set the options.  
If [Traffic](#) is switched off and [Traffic incidents](#) is switched on, the symbols are shown on the prospective route.

### Displaying weather information and other map contents

- ▶ Select .
- ▶ Select [Advanced](#).
- ▶ Select [View](#).

- ▶ Select [Map elements](#).
- ▶ Scroll up and show the [ONLINE MAP CONTENTS](#) category.
- ▶ Switch on a service, e.g. [Weather](#).  
Current weather information is displayed on the navigation map, e.g. temperature or cloud cover.

### Parking service

**!** **NOTE** Damage to the vehicle due to not observing the maximum permitted headroom clearance

If the vehicle height is greater than the maximum permitted headroom clearance, the roof and other parts of the vehicle may be damaged.

- ▶ Observe the signposted headroom clearance.
- ▶ If the vehicle height is greater than the permitted headroom clearance, do not enter.
- ▶ Observe the changed vehicle height with add-on roof equipment.

**!** **NOTE** Vehicle damage due to failure to observe local information and parking conditions

The data is based on the information provided by the respective service providers.

Mercedes-Benz does not guarantee the accuracy of the information provided in relation to the car park or parking area.

- ▶ Always observe the local information and conditions.

**i** This service is not available in all countries.

- ▶ Tap on  on the map.
- ▶ Select a parking option.  
The map shows the parking options in the vicinity.

The following information is displayed (if available):

- Destination address, distance from current vehicle position and arrival time
- Information on the multi-storey car park/car park, for example:
  - Opening times
  - Parking charges
  - Current occupancy
  - Maximum parking time
  - **Maximum clearance height**

The maximum clearance height shown by the parking service does not replace the need for observation of the actual circumstances.
- Available payment options (Mercedes pay, coins, bank notes, cards)
- Details on parking tariffs
- Number of available parking spaces
- Payment method (e.g. at parking meters)
- Services/facilities at the parking option
- Telephone number

## Telephone

### Telephony

#### Notes on telephony

**⚠ WARNING** Risk of distraction from operating integrated communication equipment while the vehicle is in motion

If you operate communication equipment integrated in the vehicle when driving, you could be distracted from the traffic situation. This could also cause you to lose control of the vehicle.

- ▶ Only operate this equipment when the traffic situation permits.
- ▶ If you cannot be sure of this, stop the vehicle whilst paying attention to road and traffic conditions and operate the equipment with the vehicle stationary.

**⚠ WARNING** Risk of an accident from operating mobile communication equipment while the vehicle is in motion

Mobile communications devices distract the driver from the traffic situation. This could also cause the driver to lose control of the vehicle.

- ▶ As the driver, only operate mobile communications devices when the vehicle is stationary.
- ▶ As a vehicle occupant, only use mobile communications devices in the areas intended for this purpose, e.g. in the rear passenger compartment.

You must observe the legal requirements for the country in which you are currently driving when operating mobile communication equipment in the vehicle.

#### **Bluetooth® connection:**

The menu view and the available functions in the phone menu are partly dependent on the Bluetooth® profile of the mobile phone connected.

If the mobile phone supports these Bluetooth® profiles, the full range of features is available:

- PBAP (Phone Book Access Profile)
  - The mobile phone's contacts are automatically displayed on the multimedia system.
- MAP (Message Access Profile)
  - The message functions of the mobile phone can be used on the multimedia system.

Irrespective of this, Bluetooth® audio functionality can be used with any mobile device.

For information on the functionality of the mobile device to be connected, see the manufacturer's operating instructions.

#### **Network connection:**

In the following cases, calls may be interrupted while driving:

- there is insufficient network coverage in the area.
- you switch to a transmitting/receiving station in which no communication channel is free.
- the SIM card used is not compatible with the network available
- a mobile phone with "Twincard" is logged into the network with the second SIM card at the same time

The multimedia system supports calls in HD Voice® for improved speech quality. A requirement for this is that the mobile phone and the mobile phone network provider of the person you are calling support HD Voice®.

Depending on the quality of the connection, the voice quality may fluctuate.

Further information can be obtained from a Mercedes-Benz service centre or at: <https://www.mercedes-benz-mobile.com/>

## Telephone menu overview

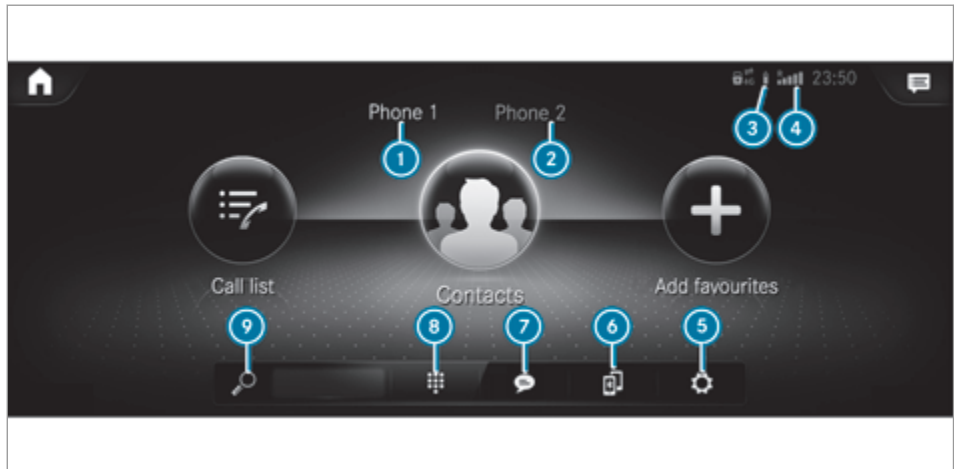

- ① Bluetooth® device name of the currently connected mobile phone/the mobile phones
- ② Bluetooth® device name of the currently connected mobile phone/the mobile phones (two phone mode)
- ③ Battery status of the connected mobile phone
- ④ Signal strength of the mobile phone network
- ⑤ Options
- ⑥ Device manager
- ⑦ Messages
- ⑧ Numerical pad
- ⑨ Contact search

## Telephony operating modes overview

Depending on the equipment, the following telephone operating modes are available:

- One mobile phone is connected to the multimedia system via Bluetooth® .
- Two mobile phones are connected with the multimedia system via Bluetooth® (two phone mode).
  - You can use all the functions of the multimedia system with the mobile phone in the foreground.
  - You can receive incoming calls and messages with the mobile phone in the background.

You can interchange the mobile phone in the foreground and background.

## Connecting a mobile phone

### Requirements:

- Bluetooth® is activated on the mobile phone (see the manufacturer's operating instructions).
- Bluetooth® is activated on the multimedia system.

Multimedia system:



### Searching for a mobile phone

- ▶ Select .
- ▶ Select **Connect new device**.



### Connecting a mobile phone

Authorisation follows using secure simple pairing.

- ▶ Select a mobile phone.  
A code is displayed in the multimedia system and on the mobile phone.
- ▶ If both codes match, confirm the code on the mobile phone.

### Functions in the Telephony menu

The functions available in the Telephony menu include the following:

- Making calls, e.g.:
  -  Accepting a call
  -  **End call**
  -  **Create conferen. call**
  - Accepting or rejecting a waiting call
- Managing contacts, e.g.:
  - Downloading mobile phone contacts
  - Editing the format of a contact's name
  - Saving contacts in the vehicle
- Receiving and sending messages, e.g.:
  - Using the read-aloud function
  - Dictating a new message

### Overview of Smartphone Integration

With Smartphone Integration, you can use certain functions on your mobile phone via the multimedia system display.

Only one mobile phone at a time can be connected via Smartphone Integration to the multimedia system. Also for use with two phone mode with smartphone integration, only one additional mobile



phone can be connected using Bluetooth® with the multimedia system.

The full range of functions for Smartphone Integration is only possible with an Internet connection. The appropriate application must be downloaded on the mobile phone to use Smartphone Integration. The mobile phone must be switched on and connected to a USB port with the  symbol on the multimedia system using a suitable cable.

Apps for Smartphone Integration

- Apple CarPlay®
- Android Auto

You can start Apple CarPlay® or Android Auto using the **Apps** menu.

Alternative: If an application is active via Smartphone Integration (e.g. when music is being played or route guidance is active), you can call up the active application using the  or  or  application buttons

You can end Smartphone Integration by disconnecting the connecting cable between the mobile phone and multimedia system.

- ⓘ Mercedes-Benz recommends disconnecting the connecting cable only when the vehicle is stationary.

When using Android Auto or Apple CarPlay®, certain vehicle data is transferred to the mobile phone. This enables you to get the best out of selected mobile phone services. Vehicle data is not directly accessible.

The following system information is transmitted:

- Software release of the multimedia system
- System ID (anonymised)

The transfer of this data is used to optimise communication between the vehicle and the mobile phone.

To do this, and to assign several vehicles to the mobile phone, a vehicle ID is randomly generated.

This has no connection to the vehicle identification number (VIN) and is deleted when the multimedia system is reset (→ page 204).

The following vehicle status data is transmitted:

- The transmission position engaged
- The distinction between parked, standstill, rolling and driving
- The day/night mode of the instrument cluster

The transfer of this data is used to alter how content is displayed to correspond to the driving situation.

The following position data is transmitted:

- Coordinates
- Speed
- Compass direction
- Acceleration direction

This data is only transferred while the navigation system is active, in order to improve it (e.g. so it can continue functioning when in a tunnel).

### Web browser overview

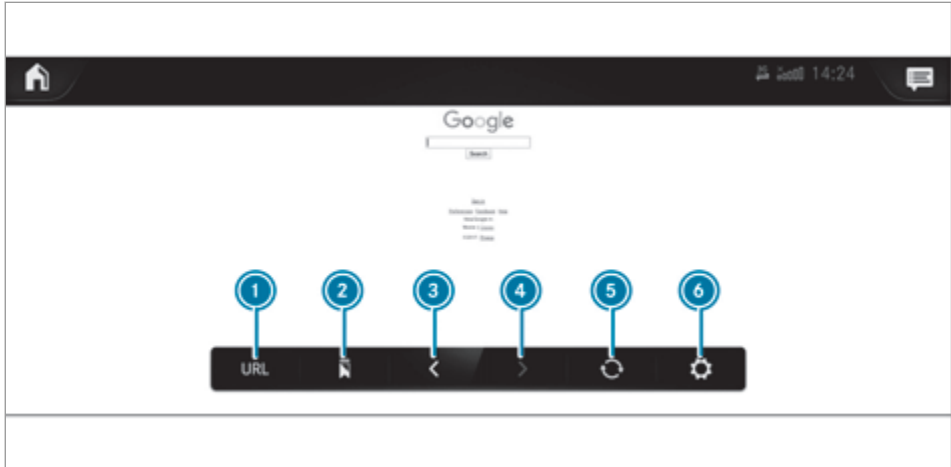

The web browser is launched on the home screen after selecting **Apps** via  **Browser**.











- ① URL entry
- ② Bookmarks
- ③ Previous website
- ④ Next website
- ⑤ To refresh/stop
- ⑥ Options
- ⓘ Some functions are country-dependent.
- ⓘ Websites cannot be shown while the vehicle is in motion.

## Radio and media

### Overview of the symbols and functions in the media menu

Symbol	Designation	Function
	Play	Select to start or continue playback.
	Pause	Select to pause the playback.

Symbol	Designation	Function
	Repeat a track	Select to repeat the current track or the active playlist. <ul style="list-style-type: none"> <li>• Select once: the active playlist is repeated.</li> <li>• Select twice: the current track is repeated.</li> <li>• Select three times: the function is deactivated.</li> </ul>
	Random playback	Select to play the tracks in random order.
	Back/forward	Select to skip to the previous or to the next track.
	Options	Select to show additional options.
	Categories	Select to show or search through available categories (e.g. playback lists, albums, artists, etc.).
	Search	Select to search in the active menu. You can search for artists or genres, for example.
	Settings	Select to make settings.
	Home	Select to return to the home screen.
	Full screen	Select to switch to full screen mode.

The following functions and settings are available in the Media menu:

- Connect external data carriers to the multimedia system (e.g. via USB or Bluetooth®)
- Playback of audio or video files

### Authorising Bluetooth® audio equipment for media playback

#### Requirements:

- Bluetooth® is activated on the multimedia system and audio equipment .
- The audio equipment supports the Bluetooth® audio profiles A2DP and AVRCP.
- The audio equipment is "visible" for other devices.

Multimedia system:



Using Bluetooth® Audio, you can play back music files via the MBUX multimedia system from an external data storage medium, e.g. your smartphone.

- ▶ To play back audio files using the multimedia system, authorise the external data storage medium on the MBUX multimedia system.









#### Authorising a new Bluetooth® audio device

- ▶ Select **Connect new device**.
- ▶ Select an audio device. Authorisation starts. A code is displayed on the multimedia system and on the mobile phone.
- ▶ If the codes are identical, confirm on the audio equipment.
- ▶ Select **Only as Bluetooth audio device**. The Bluetooth® audio equipment is connected with the multimedia system.

## Connecting previously authorised Bluetooth® audio equipment

- ▶ Select a Bluetooth® audio device from the list.
- The connection is established.

## Overview of the symbols and functions in the radio menu





Symbol	Designation	Function
	Home	Select to return to the home screen.
	Messaging	Select to call up messaging.
	Back/forward	Select to skip to the previous or to the next station.
	Settings	Select to show further options. Settings can be made to the following additional functions, for example: <ul style="list-style-type: none"> <li>• Navigation and traffic announcements</li> <li>• Frequency fix function</li> <li>• Radio additional text</li> <li>• Emergency warnings</li> </ul> The setting options are country-dependent.
	Full screen	Select to switch to the DAB slide show. This function is not available in all countries.
	Silent function	Select to switch off the sound.
	Storing radio stations	Select to save a radio station in the station list.
	Station list	Select to display the station list.
	Search	Select to browse the active menu, for example, by artist or genre.

Depending on the frequency band selected, different functions are available to you.

Select the desired frequency band in the radio menu head runner.

### Additional functions of TuneIn Radio

- ⓘ A relatively large volume of data can be transmitted when using TuneIn Radio.

Symbol	Designation	Function
	Settings	The following additional settings are available in the Tuneln Radio menu: <ul style="list-style-type: none"> <li>• Selecting stream</li> <li>• Logging on to or out of the Tuneln account</li> </ul>
	Favourites	Select during playback to save the station currently set as a favourite.
	Play/Pause	Select to start, stop or continue playback.
	To browse	Select to choose a category and then a radio station.

## Sound settings

### Overview of functions in the Sound menu

The sound system is available for all functions in the radio and media modes. The settings, for example for the equaliser, effect the playback of all media sources.

The following functions are available:

- Equaliser:
  - Treble, mid-range and bass
- Balance and fader
- Volume:
  - Automatic volume adjustment

## Notes on loading guidelines

### **⚠ DANGER** Risk of poisoning from exhaust gases

Combustion engines emit poisonous exhaust gases, such as carbon monoxide. Exhaust gases can enter the vehicle interior if the tailgate is open when the engine is running, especially if the vehicle is in motion.

- ▶ Always switch off the engine before opening the tailgate.
- ▶ Never drive with the tailgate open.

### **⚠ WARNING** Risk of injury from unsecured objects in the vehicle

When objects are unsecured or inadequately secured, they can slip, tip over or be thrown about, striking vehicle occupants.

This also applies to:

- luggage or loads
- seats which have been removed and are being transported in the vehicle in an exceptional case

There is a risk of injury, particularly in the event of braking manoeuvres or abrupt changes in direction.

- ▶ Always stow objects in such a way that they cannot be tossed about.
- ▶ Before travelling, secure objects, luggage or load to prevent them slipping or tipping over.
- ▶ When a seat is removed, keep it preferably outside the vehicle.

### **⚠ WARNING** Risk of accident due to incorrectly placed load

The centre of gravity of the load may be too high and/or too far back.

This can significantly impair the driving, steering and braking characteristics.

- ▶ Always ensure that the centre of gravity of the load is between the axles and as low as possible near the rear axle.

### **⚠ WARNING** Risk of accident due to exceeding the permissible wheel/axle loads or the gross vehicle weight

The driving characteristics, as well as steering and braking, may be greatly impaired. Overloaded tyres may overheat and burst as a consequence.

- ▶ When transporting a load, always observe the permissible wheel loads, axle loads and the maximum permissible gross mass for the vehicle (including occupants).

### **⚠ WARNING** Risk of injury if unsuitable climbing aids are used

In the event that you use openings in the bodywork or attachments as steps, you could:

- Slip and/or fall.
  - Damage the vehicle and thus slip and fall.
- ▶ Always use non-slip, stable climbing aids, e.g. a suitable ladder.

### **ℹ NOTE** Damage caused by the use of openings in the bodywork or detachable part as a step

Using the lower guide of the sliding door (carriage) as a step can damage the trim and/or mechanism of the sliding door.

- ▶ Do not use the guide of the sliding door (carriage) as a step.

If you are using a roof luggage rack, please note the maximum roof load and the maximum load capacity of the roof luggage rack (→ page 283).

The handling characteristics of your vehicle are dependent on the load distribution.

Therefore, please observe the following notes when loading:

- the load must not protrude above the upper edge of the seat backrests.
- if possible, always transport the load in the load compartment.
- fasten the load to the tie-down eyes and distribute the load evenly among them.

- if available, use a load protection net to secure the load (→ page 221).
- use tie-down eyes and fastening components which are suitable for the weight and size of the load.

Observe the operating instructions of the manufacturer when using load securing aids or lashing material and the notes on their expiration dates.

In the following cases, load securing aids or lashing materials are worn out, should not be used and must be replaced:

- there is missing or illegible identification
- there is cord breakage or damage to load-bearing seams or other traces of cracking
- there are cuts, holes, deformations, crushed areas or other damage
- there is damage to clamping elements or fasteners

If the luggage compartment floor or loading area are damaged in the event of an accident, have the tie-down eyes and the lashing material checked at a qualified specialist workshop.

Even if you adhere to all the loading guidelines, an increased load increases the risk of injury in the event of an accident.

### Before loading

Check and, when necessary, adjust the tyre pressure (→ page 256).

### When loading

Observe the following when loading the vehicle:

- Never exceed the permissible axle load or the vehicle's permissible gross mass.  
The vehicle's kerb weight is increased if accessories or optional equipment are fitted. This reduces the maximum payload.
- Observe the notes on load distribution (→ page 218).
- Observe the notes on load securing (→ page 219) and the legal requirements of the country in which you are currently driving.
- Observe the information on the carrier systems (→ page 224).

### After loading

Observe the following after loading the vehicle:

- Check that the luggage and/or load is secure before every journey and at regular intervals on long trips.
- Close all doors and the tailgate.
- Adjust the range of the headlamps according to the vehicle load (→ page 110).
- Adjust the tyre pressure according to the vehicle load (→ page 256).
- Adapt your driving style according to the vehicle load.

### Notes on distributing the load within the vehicle

**!** **NOTE** Damage to the floor covering due to uneven loading

Excessive point loading on the load compartment floor or on the load area can negatively affect the driving characteristics and could damage the floor covering.

▶ Distribute the load evenly. When doing so, ensure that the overall centre of gravity of the load is always as low and close to the centre as possible and between the axles near the rear axle.

Observe the following notes:

- Always transport loads in the load compartment and with the seat backrests folded up and properly locked in position.
- Always place the load against the front or rear seat backrests.
- Move large and heavy loads as far as possible towards the front of the vehicle in the direction of travel, against the front or rear seats. Stow loads flush with the rear or front seats.
- Additionally secure the load with suitable load securing aids or lashing material.
- The load must not protrude above the upper edge of the seat backrests.
- Transport loads behind seats that are not occupied.
- If the rear bench seat is not occupied, insert the seat belts crosswise into the seat belt buckle of the opposite seat belt.

## Load compartment variants

You can vary the load compartment according to your transportation requirements as follows:

- by folding the rear seat backrests or rear bench seat backrests forward to the table position
- by folding the rear seats forwards
- by folding the rear bench seat forwards
- by removing the rear seats and/or the rear bench seat
- by removing the seat/bunk combination
- by folding up or removing the bed extension of the seat/bunk combination

You will find information about the rear seats and the rear bench seat in the "Seats" section (→ page 77).

## Securing loads

### Notes on load securing

**!** **NOTE** Damage to the vehicle if the maximum loading capacity of the lashing points is exceeded

If you combine various lashing points to secure a load, always take the maximum loading capacity of the weakest lashing point into account.

During maximum full-stop braking, forces may act which can multiply the weight of the load.

- ▶ Always use several lashing points to distribute and spread the load.
- ▶ Distribute the load on the lashing points evenly.

Observe the information relating to the maximum loading capacity of the lashing points (→ page 283).

As the driver, you are responsible for ensuring the following:

- The load is secured against slipping, tipping, rolling or falling off.  
Take usual traffic conditions as well as swerving or full brake application and bad roads into account.
- The applicable requirements and guidelines relating to load-securing practices are met.  
If this is not the case, this may constitute a punishable offence, depending on local legisla-

tion and any ensuing consequences. Observe country-specific laws.

Make sure that the load is secure before every journey and at regular intervals during a long journey. Adjust the load securing as necessary. Information on how to secure loads correctly can be obtained from the manufacturers of the load securing aids or lashing material for load securing, for example.

Also observe the notes on loading guidelines (→ page 217).

When securing loads, observe the following:

- Fill spaces between the load and the load compartment walls or wheel wells. For this purpose, use rigid load securing aids, such as chocks, wooden fixings or padding.
- Attach secured and stabilised loads in all directions.

Use the lashing points or the tie-down eyes and guide rails in the rear compartment.

Only use lashing materials, such as lashing nets and lashing straps, which have been tested in accordance with current standards (e.g. DIN EN). Always use the lashing points closest to the load and pad sharp edges.

- i** You can obtain lashing material tested in accordance with current standards (e.g. DIN EN) from a specialist company or from a qualified specialist workshop.

### Note on the lashing points and tie-down eyes on the load compartment floor for passenger vehicles (vehicle category M1)

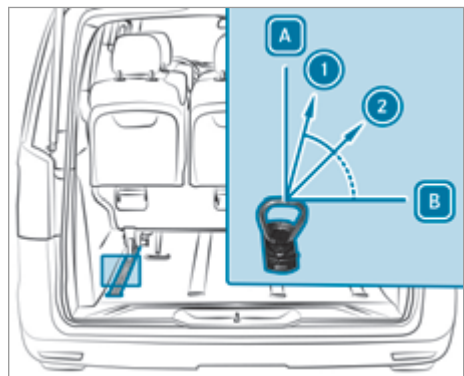

Example: lashing angle for best load security

- A** Vertical to the load compartment floor
- B** Load compartment floor

- ① Direction of pull with 75° lashing angle
- ② Direction of pull with 45° lashing angle

The lashing angle is the angle formed between the load compartment floor and the lashing material. For optimum load securing in accordance with standard ISO 27955 the lashing angle must be between 45° ② and 75° ①. The maximum nominal tensile load of 350 daN for the tie-down eyes in the load compartment floor or in the guide rails may not be exceeded.

### Overview of lashing points

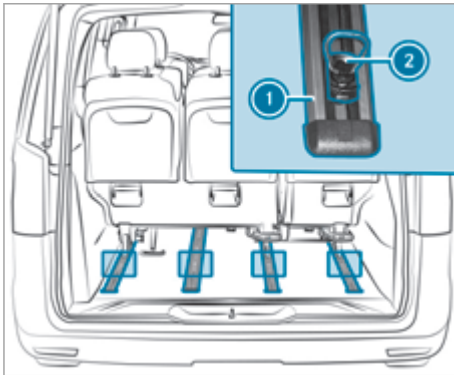

Example: variable lashing points in the guide rails

- ① Guide rails
- ② Tie-down eye

Do not attempt to modify or repair the lashing points, tie-down eyes or lashing materials. Read the information on qualified specialist workshops (→ page 25).

### Fitting and removing tie-down eyes

**⚠ WARNING** Risk of injury due to incorrectly installed tie-down eyes

If the tie-down eyes are not correctly installed, they can slip or tear out.

This may cause objects, luggage or the load to slip, tip over or be thrown about the vehicle interior, striking vehicle occupants.

▶ Make sure that the tie-down eyes are correctly installed and do not move.

▶ Observe the notes on the loading guidelines and on securing loads (→ page 217).

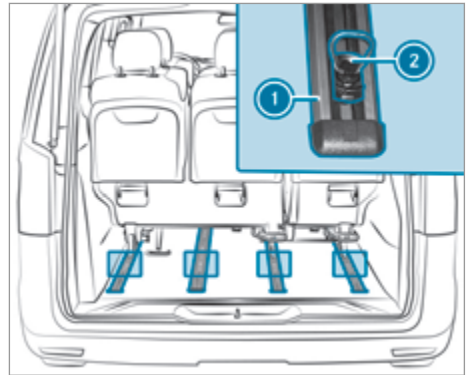

Example: guide rails

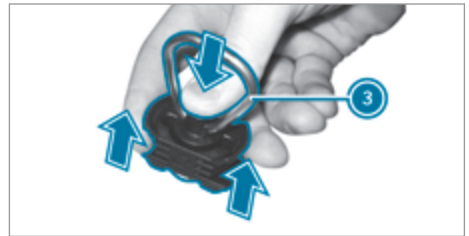

Tie-down eyes for guide rails

### Fitting

- ▶ Turn metal retaining ring ③ so that it is parallel to the long axis of tie-down eye ② as illustrated. The locking pin can only be pushed down sufficiently and allow the tie-down eye to be fitted, moved or removed, if the metal retaining ring is parallel to the long axis of the tie-down eye.
- ▶ Hold tie-down eye ② between your forefinger and middle finger as illustrated, and place your thumb through metal retaining ring ③ and on the central pressure point.
- ▶ Use your thumb to push the locking pin down as far as it will go.
- ▶ Push tie-down eye ② near the load using the notches on guide rail ①, and move it approximately 12 mm.
- ▶ Remove your thumb from the pressure point and slide tie-down eye ② until it engages.
- ▶ Turn metal retaining ring ③ so that it is perpendicular to the long axis of tie-down eye ②. The locking pin cannot be pushed down far if the metal retaining ring is perpendicular to the long axis of the tie-down eye. This prevents the

tie-down eye from being released unintentionally, e.g. if the tie-down eye is stepped on.

- ▶ Check that tie-down eye ② is seated correctly. The tie-down eye cannot be moved.

### Removing

- ▶ Turn metal retaining ring ③ so that it is parallel to the long axis of tie-down eye ②.
- ▶ Grip tie-down eye ② as described above under fitting and use your thumb to push the locking pin down as far as it will go.
- ▶ Slide tie-down eye ② and pull it up and out through the notch of guide rail ①.

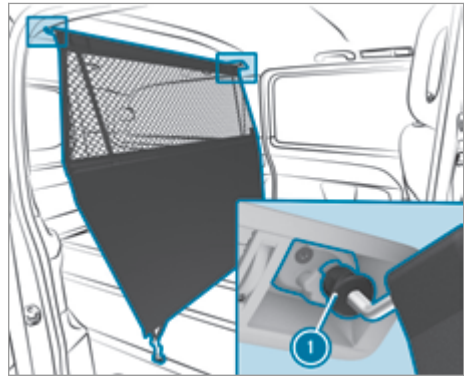

Upper retainer

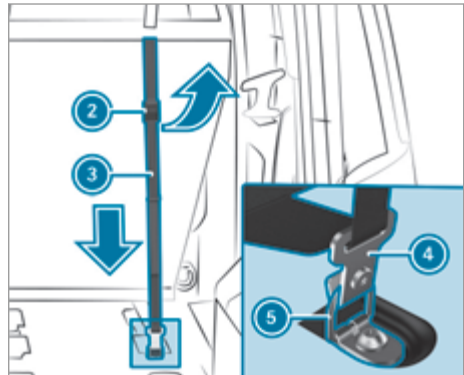

Floor anchorage (example: secured tie-down eye)

## Load securing aid

### Removing or fitting a load protection net

**⚠ WARNING** Risk of injury or death due to objects being poorly secured

The load protection net alone cannot restrain or secure heavy objects, luggage or heavy loads.

You could be hit by an unsecured load during sudden changes in direction, braking or in the event of an accident.

- ▶ Always stow objects in such a way that they cannot be thrown about the vehicle.
- ▶ Secure objects, luggage or loads against slipping or tipping over, e.g. by using lashing material, even when you are using the load protection net.

**⚠ WARNING** Risk of injury due to sitting behind a load protection net

Vehicle occupants can be pressed against the load protection net. There is a risk of injury!

- ▶ Never allow vehicle occupants to sit behind the load protection net.

The load protection net partitions the load compartment. It protects vehicle occupants from light objects and/or luggage slipping or tipping over.

You can install the load protection net at an angle behind the front seats or behind the first row of rear seats.

- ▶ Observe the notes on securing loads (→ page 219).

### Fitting

- ▶ Remove the luggage compartment partition if necessary (→ page 222).
- ▶ Clip the load protection net into upper retainers ① in such a way that tensioning straps ③ face the rear of the vehicle.
- ▶ Fit tie-down eyes ⑤ into the guide rails close to the rear seat legs (→ page 220). Position them at least 5 cm from the seat legs to allow subsequent movement of the rear seat.
- ▶ Check that tie-down eyes ⑤ are seated correctly. Tie-down eyes ⑤ should not move.
- ▶ Clip hooks ④ on tensioning straps ③ into tie-down eyes ⑤.
- ▶ Fold tensioning element ② up.

- ▶ Pull the loose end of tensioning straps ③ down in the direction of the arrow until tensioning straps ③ are tight.
- ▶ Fold tensioning element ② down to achieve the final tension on the straps.
- ▶ If necessary, fit the luggage compartment partition (→ page 222).
- ▶ After travelling a short distance, check that the load protection net is taut, and retighten it if necessary.

### Removing

- ▶ Remove the luggage compartment partition if necessary (→ page 222).
- ▶ Fold tensioning element ② up. Tensioning straps ③ are slack.
- ▶ Unclip hooks ④ of tensioning straps ③ from tie-down eyes ⑤ at the bottom.
- ▶ Unclip the load protection net from upper retainers ①.
- ▶ When required, remove tie-down eyes ⑤ (→ page 220).
- ▶ If necessary, fit the luggage compartment partition (→ page 222).
- ▶ Roll up the load protection net and fasten it, still rolled up, using the Velcro fasteners.

### Adjusting the front seat with the load protection net fitted

- ▶ Fold tensioning element ② on straps ③ upwards. The load protection net slackens.
- ▶ Correctly adjust the front seat.
- ▶ Re-tension the load protection net.

### Using the luggage compartment partition

**⚠ WARNING** Risk of injury from unsecured objects in the vehicle

When objects are unsecured or inadequately secured, they can slip, tip over or be thrown about, striking vehicle occupants.

This also applies to:

- luggage or loads
- seats which have been removed and are being transported in the vehicle in an exceptional case

There is a risk of injury, particularly in the event of braking manoeuvres or abrupt changes in direction.

- ▶ Always stow objects in such a way that they cannot be tossed about.
- ▶ Before travelling, secure objects, luggage or load to prevent them slipping or tipping over.
- ▶ When a seat is removed, keep it preferably outside the vehicle.

**⚠ WARNING** Risk of accident or injury when the luggage compartment partition is not locked in position

The luggage compartment partition can come loose when driving and be thrown about the vehicle interior.

- ▶ Fit the luggage compartment partition as described.
- ▶ After fitting the luggage compartment partition, always make sure that the luggage compartment partition is locked and folded down.

**! NOTE** Damage to the luggage compartment partition due to heavy loads

If the luggage compartment partition is loaded with too much weight, the fixture points and the luggage compartment partition may be damaged.

- ▶ Do not load more than 50 kg on the luggage compartment partition.

The luggage compartment partition is only secured correctly when both levers are locked.

- ▶ Comply with the loading guidelines (→ page 217).

## Opening the storage compartments

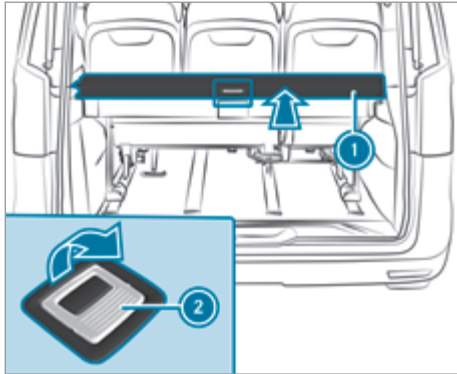

- ▶ Pull handle ② in the direction of the arrow. Cover ① folds upwards in the middle.
- ▶ Slide cover ① to the stop in the direction of the arrow.

## Closing the storage compartments

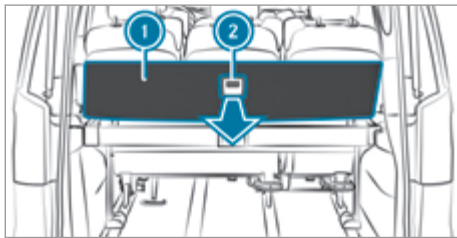

- ▶ Pull cover ① on handle ② in the direction of the arrow.
- ▶ Push cover ① down in the middle until it is fully closed.

## Folding up the luggage compartment partition to an angle of 70°

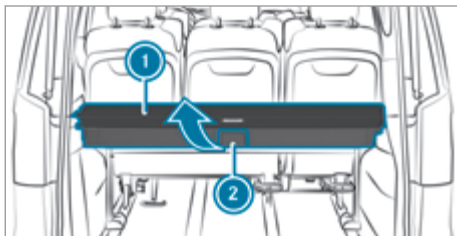

- ▶ Pull handle ② in the direction of the arrow. Luggage compartment partition ① is released.

- ▶ Fold up luggage compartment partition ①.

Make sure that luggage compartment partition ① is always folded down when the vehicle is moving.

## Folding down the luggage compartment partition

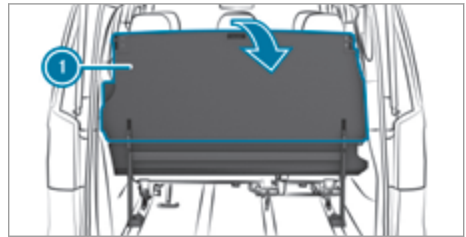

- ▶ Fold down luggage compartment partition ① until it engages. Luggage compartment partition ① is locked.

## Removing the luggage compartment partition

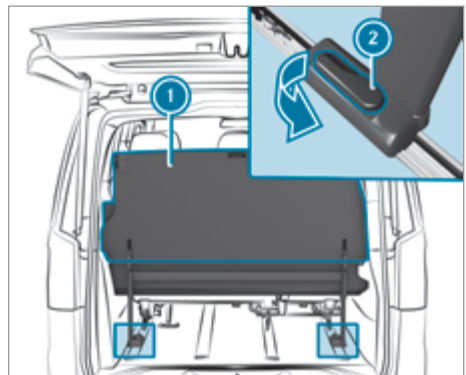

- ▶ Fold up luggage compartment partition ①.
- ▶ Swing levers ② inwards. Luggage compartment partition ① is released.
- ▶ Remove luggage compartment partition ①.

## Fitting the luggage compartment partition

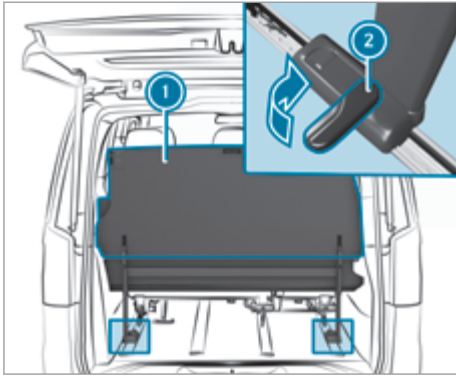

If possible, fit luggage compartment partition ① with the help of another person.

- ▶ Place luggage compartment partition ① into the vehicle at an angle.
- ▶ Rotate luggage compartment partition ① in the vehicle and insert it into the guide rails.

The guide rails have triangular markings at the place to be inserted which must be at the same height as levers ②.

- ▶ Swing levers ② outwards.  
Luggage compartment partition ① is locked.
- ▶ Fold luggage compartment partition ① down.

## Carrier systems

### Notes on carrier systems

**⚠ WARNING** Risk of accident due to exceeding the maximum roof load

The vehicle centre of gravity and the usual driving characteristics as well as the steering and braking characteristics alter.

If you exceed the maximum roof load, the driving characteristics, as well as steering and braking, will be greatly impaired.

- ▶ Never exceed the maximum roof load and adjust your driving style.

You can find information on the maximum roof load under "Lashing points and carrier systems" (→ page 283).

**!** **NOTE** Damage due to exceeding the maximum permissible roof load

If the weight of the roof luggage, including the roof luggage rack, exceeds the maximum permissible roof load, this can cause damage to the vehicle.

- ▶ Do not exceed the maximum permissible roof load.
- ▶ Arrange the supporting feet of the roof luggage rack at an even distance from each other.
- ▶ Install the basic carrier bars for rail in front of and behind the mid-section support.

**!** **NOTE** Damage to the threaded holes of the roof luggage rack due to an excessively high tightening torque

An excessively high tightening torque or an insufficient screw-in depth can cause damage to the thread of the roof luggage rack's threaded holes.

- ▶ Tighten the screws to a maximum torque of 10 Nm.
- ▶ Comply with the minimum screw penetration of four revolutions in the thread.
- ▶ To avoid damage to the vehicle, use roof and rear luggage racks that have been tested and approved for Mercedes-Benz.

**!** **NOTE** Damage to the vehicle due to not observing the maximum permitted headroom clearance

If the vehicle height is greater than the maximum permitted headroom clearance, the roof and other parts of the vehicle may be damaged.

- ▶ Observe the signposted headroom clearance.
- ▶ If the vehicle height is greater than the permitted headroom clearance, do not enter.
- ▶ Observe the changed vehicle height with add-on roof equipment.

**!** **NOTE** The operating permit may be invalidated due to the illegal installation of trailer hitches

The installation – including retrofitting – of a non-folding or non-removable trailer hitch that even partially conceals the license plate or the lighting system is prohibited.

► Observe the applicable legal regulations for the installation of trailer hitches.

You can install a roof luggage rack on the roof and, for example, a rear bicycle rack on the tailgate.

Install the cover caps of the securing thread after removing the roof luggage rack.

If you have installed a rear luggage rack on the tailgate, the additional weight will restrict the assistance offered by the pneumatic springs when you open the tailgate. You will then need more force to open the tailgate. At low outside temperatures below freezing point, you should provide additional support for the tailgate after opening it in order to prevent it from lowering unintentionally.

## Notes on maintenance



**ENVIRONMENTAL NOTE** Environmentally pollution from disposal not in an environmentally responsible manner

If, for operating reasons, individual maintenance work is carried out under your own direction, the environmental protection requirements must be observed. When disposing of operating fluids, e.g. engine oil, the legal requirements must be observed. This also affects all parts that have come into contact with operating fluids, e.g. filters.

- ▶ Dispose of empty containers, cleaning cloths and care products in an environmentally responsible manner.
- ▶ Follow the instructions for use of care products.
- ▶ Do not allow the engine to run longer than necessary when stationary.

When working on the vehicle, comply with all safety regulations, such as the operating instructions, regulations concerning hazardous materials, environmental protection measures, work safety and accident prevention regulations.

**i** You must secure the vehicle on jack stands of sufficient load-bearing capacity if work is being carried out underneath the vehicle.

Please also refer to the notes about qualified specialist workshops (→ page 25).

The scope and regularity of the inspection and maintenance work primarily depend on the often diverse operating conditions.

You can obtain further information concerning the servicing of your vehicle from a qualified specialist workshop, e.g. a Mercedes-Benz Service Centre.

You will find information about operating fluids approved for Mercedes-Benz and capacities under "Operating Fluids and Capacities" (→ page 274).

Observe the information under "Mercedes-Benz GenuineParts" (→ page 16).

## Service interval display

### Service interval display function

The ASSYST PLUS service interval display on the instrument cluster display provides information on the remaining time or distance before the next service due date.

Under arduous operating conditions or if the vehicle is subjected to increased loads, the ASSYST PLUS service interval display may shorten the service interval.

You can obtain further information concerning the servicing of your vehicle from a qualified specialist workshop.

### Displaying the service due date

#### Requirements

- The ignition is switched on.

On-board computer:

Service ASSYST PLUS

The next service due date is displayed.

**To exit the display:** press the  or  steering-wheel button.

### Information on regular maintenance work



**NOTE** Premature wear through failure to observe service due dates

Maintenance work which is not carried out at the right time or incompletely can lead to increased wear and damage to the vehicle.

- ▶ Adhere to the prescribed service intervals.
- ▶ Always have the prescribed maintenance work carried out at a qualified specialist workshop.

### Notes on special service requirements

The prescribed service interval is based on normal vehicle use. Maintenance work will need to be performed more often than prescribed if the vehicle is operated under arduous operating conditions or increased loads.

Arduous operating conditions include:

- Regular city driving with frequent intermediate stops
- frequent short-distance driving
- Frequent operation in mountainous terrain or on poor road surfaces
- when the engine is often left idling for long periods
- operation in particularly dusty conditions and/or if air-recirculation mode is frequently used

In these or similar operating conditions, have the air filter, engine oil and oil filter, for example, replaced more frequently.

If the vehicle is subjected to increased loads, the tyres must be checked more frequently. You can obtain further information at a qualified specialist workshop.

### Non-operational times with the battery disconnected

The ASSYST PLUS service interval display can calculate the service due date only when the battery is connected.

- ▶ Display and note down the service due date on the instrument cluster before disconnecting the battery (→ page 226).

## Engine compartment

### Opening and closing the bonnet

**⚠ WARNING** Risk of accident due to driving with the bonnet unlocked

The bonnet may open and block your view.

- ▶ Never release the bonnet when driving.
- ▶ Before every trip, ensure that the engine bonnet is locked.

**⚠ WARNING** Risk of accident and injury when opening and closing the bonnet

The bonnet may suddenly drop into the end position.

There is a risk of injury for anyone in the engine bonnet's range of movement.

- ▶ Do not open or close the bonnet if there is a person in the bonnet's range of movement.

**⚠ WARNING** Risk of injury from touching components under voltage

The ignition system and the fuel injection system work under high voltage. You could receive an electric shock.

- ▶ Never touch components of the ignition system or the fuel injection system when the ignition is switched on.

The following are examples of live components:

- Ignition coils
- Spark plug connectors
- Injectors

**⚠ WARNING** Risk of burns from hot component parts in the engine compartment

Certain component parts in the engine compartment can be very hot, e.g. the engine, the cooler and parts of the exhaust system.

- ▶ Allow the engine to cool down and only touch component parts described in the following.

**! NOTE** Damage to bonnet or windscreen wipers when opening the bonnet

If the windscreen wipers have been folded back from the windscreen when the bonnet is opened, the windscreen wipers or the bonnet may be damaged.

- ▶ Ensure that the windscreen wipers have not been folded back from the windscreen.

### Opening the bonnet

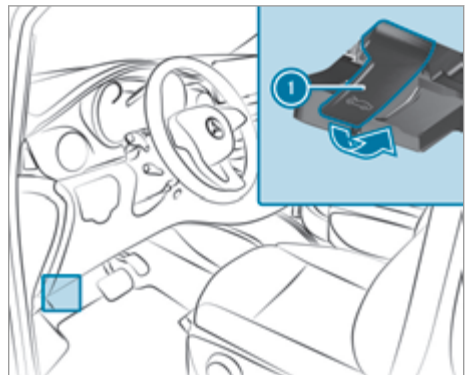

- ▶ Pull handle ① to release the bonnet.

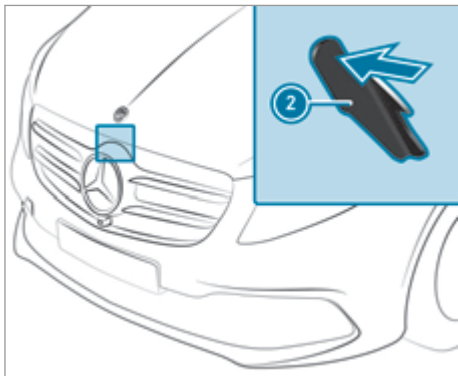

- ▶ Reach into the gap, push lever ② of the bonnet catch to the left and lift the bonnet. When the bonnet has opened around 40 cm, it will be automatically opened and held by the gas pressure spring dampers.

### Closing the bonnet

**⚠ WARNING** Risk of fire due to flammable materials in the engine compartment or on the exhaust system

Flammable materials may ignite.

- ▶ Ensure that there are no flammable external materials in the engine compartment or on the exhaust system after maintenance work has been carried out.

**! NOTE** Damage to the bonnet due to pressing it closed manually

Pushing the bonnet closed with your hands could damage it.

- ▶ To close the bonnet, let it drop from the specified height.

- ▶ Lower the bonnet and let it fall from a height of approximately 30 cm, applying a little force as you let it go.
- ▶ If the bonnet remains slightly open, open it again and let it fall, applying slightly more force as you let it go, until it engages.

## Engine oil

### Checking engine oil level with on-board computer (engine without oil dipstick)

#### Requirements:

- The engine oil level is determined during driving.
- The engine is at normal operating temperature.
- The vehicle is level during the measuring process.
- The bonnet is not open.

Depending on the driving profile, the oil level can be displayed only after a driving time of up to 30 minutes and only when the ignition is switched on.

On-board computer:

↳ Service ▶▶ Engine oil level

### One of the following messages appears on the display of the on-board computer:

#### Engine oil level Measurement in progress...

- ▶ Measurement of the oil level not yet possible. Repeat the query after driving for a maximum of 30 minutes.

#### Engine oil level OK

The bar for displaying the oil level on the display is green and is between "min" and "max".

- ▶ Do not top up oil. The engine oil level is correct.

#### Engine oil level Warm up engine

- ▶ Warm up the engine to operating temperature.

#### Engine oil level Correct measurement only if vehicle is on level ground

- ▶ Park the vehicle on a level surface.

#### Engine oil level Add 1,0 l

The bar for displaying the oil level on the display is orange and is below "min".

The oil level is too low.

- ▶ Add 1 l of engine oil (→ page 230).

#### Engine oil level Reduce oil level

The bar for displaying the oil level on the display is orange and is above "max".

The oil level is too high.

- ▶ Siphon off any excess engine oil that has been added. To do so, consult a qualified specialist workshop.

#### For engine oil level turn on ignition

- ▶ Switch the ignition on to check the engine oil level.

#### Engine oil level System inoperative

The fill level sensor is defective or not plugged in.

- ▶ Have the oil level display checked at a qualified specialist workshop.

#### Engine oil level System currently unavailable.

- ▶ Close the bonnet.

### Checking the engine oil level with the on-board computer (engine with oil dipstick)

#### Requirements:

- The vehicle is level during the measuring process.
- The engine is switched off at normal operating temperature.
- A waiting period of five minutes is observed.
- The ignition is switched on.

To check the engine oil level with the on-board computer, the engine must have a fill level sensor. If not, the engine oil level can be checked only with the oil dipstick (→ page 229).

On-board computer:

↗ Service ▶▶ Engine oil level

### The following messages may appear on the display of the on-board computer:

#### Engine oil level OK

- ▶ Do not top up oil.

#### Engine oil level Add 1,0 l

- ▶ Add the specified quantity of oil (→ page 230).
- ▶ Repeat the engine oil measurement after a few minutes.

#### Engine oil level Reduce oil level

The oil level is too high.

- ▶ Siphon off any excess engine oil that has been added. To do so, consult a qualified specialist workshop.

#### For engine oil level turn on ignition

- ▶ Switch on the ignition.

#### Waiting period for engine oil level not observed

- ▶ If the engine is at normal operating temperature, repeat the engine oil measurement after approximately five minutes.
- ▶ If the engine is not at normal operating temperature, repeat the engine oil measurement after approximately 30 minutes.

#### Engine oil level Not with the engine running

- ▶ Switch off the engine and, when it is at normal operating temperature, wait approximately five minutes before measuring the engine oil level.

#### Engine oil level System inoperative

The engine oil level measurement is malfunctioning.

- ▶ Check the oil level using the oil dipstick (→ page 229).
- ▶ Have the oil level display checked at a qualified specialist workshop.

### Checking the engine oil level with an oil dipstick

**⚠ WARNING** Risk of burns from hot component parts in the engine compartment

Certain component parts in the engine compartment can be very hot, e.g. the engine, the cooler and parts of the exhaust system.

- ▶ Allow the engine to cool down and only touch component parts described in the following.

The engine oil becomes dirty during operation, loses quality and also gradually loses volume. Check the oil level regularly and top up the oil or have it changed if necessary.

Regularly check the fluid level and the major assemblies for leaks. If you detect fluid loss, for example, oil drops on the vehicle parking space, consult a qualified specialist workshop as quickly as possible.

- ▶ Only check the oil level when the engine is at normal operating temperature.

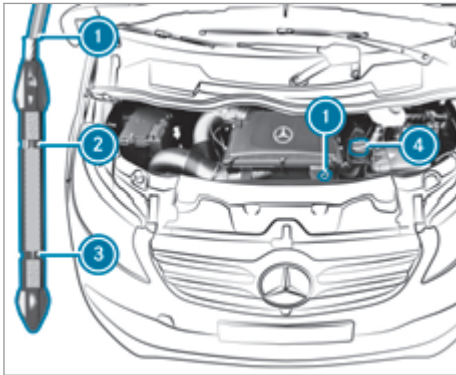

Oil dipstick and engine oil filler opening (example: petrol engine)

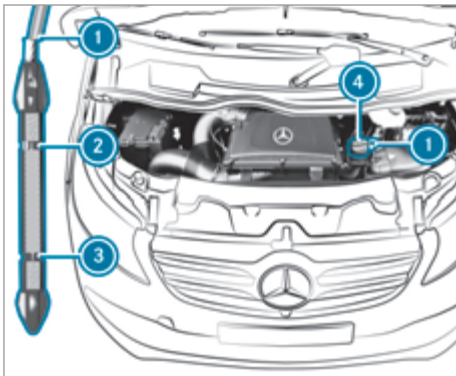

Oil dipstick and engine oil filler opening (example: diesel engine)

- ▶ Pull oil dipstick ① out of the dipstick tube.
- ▶ Wipe the oil dipstick ① using a lint-free cloth.
- ▶ Insert the oil dipstick ① back into the guide tube as far as it will go and pull it out again. If the level is between MIN mark ③ and MAX mark ②, the oil level is adequate.
- ▶ If the oil level has dropped to or below minimum mark ③, open cap ④ and top up the engine oil (→ page 230).

The difference in quantity between marks ② and ③ depends on the engine:

- Diesel engines, about 2 l
- Petrol engines about 1.5 litres

## Topping up the engine oil

**⚠ WARNING** Risk of fire and injury from engine oil

If engine oil comes into contact with hot component parts in the engine compartment, it may ignite.

- ▶ Make sure that no engine oil is spilled next to the filler opening.
- ▶ Allow the engine to cool off and thoroughly clean the engine oil from component parts before starting the vehicle.

**⚠ WARNING** Risk of burns from hot component parts in the engine compartment

Certain component parts in the engine compartment can be very hot, e.g. the engine, the cooler and parts of the exhaust system.

- ▶ Allow the engine to cool down and only touch component parts described in the following.

**! NOTE** Damage caused by topping up too much engine oil

Too much engine oil can damage the engine or the catalytic converter.

- ▶ Have excess engine oil removed at a qualified specialist workshop.

**! NOTE** Engine damage due to use of additives in the engine oil

The use of additional additives in the engine oil can damage the engine.

- ▶ Do not use any additional additives in the engine oil.

**🌿 ENVIRONMENTAL NOTE** Environmental damage due to hydraulic fluid level spillages while topping up

If fluid spills onto soil, the environment will be damaged.

- ▶ Make sure that no fluid spills while topping up.

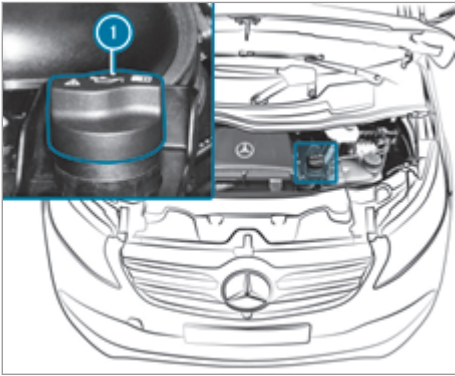

Example: engine oil filler opening

- ▶ Observe the information regarding approved engine oil under "Operating fluids and capacities" (→ page 278).
- ▶ Unscrew and remove the cap ❶.
- ▶ Top up engine oil.
- ▶ Fit the cap ❷ on the filler opening and tighten.  
When doing so, make sure that the cap engages correctly.
- ▶ If present, check the oil level using the oil dipstick (→ page 229).
- ▶ In the case of vehicles without an oil dipstick, check the oil level with the on-board computer after the next journey (→ page 228).

It is necessary to run the engine for an extended period after each oil top up to correctly detect the oil level. Fill level changes during oil top ups may not be immediately visible. Depending on the driving profile, the new oil level can only be displayed after a driving time of up to 60 minutes.

If necessary, only top up the quantity of oil shown in the instrument cluster display and check the oil level again after the next journey.

### Checking/topping up the coolant

- ⚠ **WARNING** Risk of fire- and injury from antifreeze

If antifreeze comes into contact with hot component parts in the engine compartment, it may ignite.

- ▶ Allow the engine to cool down before you top up the antifreeze.

- ▶ Make sure that no antifreeze spills out next to the filler opening.
- ▶ Thoroughly clean the antifreeze from component parts before starting the vehicle.

- ⚠ **WARNING** Risk of scalding from hot coolant

If you open the cap, you could be scalded.

- ▶ Let the motor cool down before opening the cap.
- ▶ When opening the cap, wear protective gloves and safety glasses.
- ▶ Open the cap slowly to release pressure.

Check and top up the coolant only when the vehicle is stationary and in a horizontal position and the engine has cooled down. The coolant temperature must be below 50°C.

- ⚠ **WARNING** Risk of burns from hot component parts in the engine compartment

Certain component parts in the engine compartment can be very hot, e.g. the engine, the cooler and parts of the exhaust system.

- ▶ Allow the engine to cool down and only touch component parts described in the following.

Coolant contains glycol and is therefore poisonous.

- ▶ Observe the information under "Operating fluids and capacities" (→ page 280).

- ⓘ **NOTE** Paintwork damage due to coolant

If coolant gets on painted surfaces, the paintwork can be damaged.

- ▶ Add coolant carefully.
- ▶ Remove spilled coolant.

Regularly check the engine cooling system and the heating system for leaks. If there is a loss of coolant, have the cause determined and rectified in a qualified specialist workshop without delay.

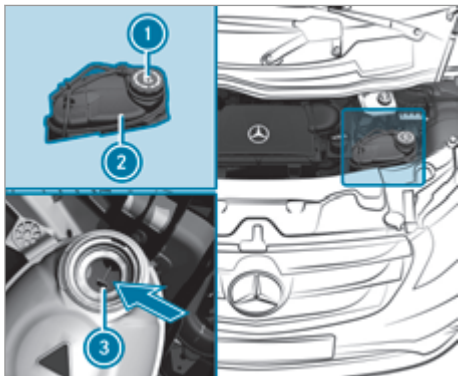

Example: cap and coolant expansion reservoir

### Checking the coolant level

- ▶ Slowly turn the cap ① of the coolant expansion reservoir ② half a turn anti-clockwise and allow overpressure to escape.
- ▶ Turn cap ① further and remove it.

The coolant level is correct in the following cases:

- Up to marker bar ③ when the engine is cold
- If the engine is warm, up to 1.5 cm over marker bar ③

### Top up the coolant

Only use coolant approved for Mercedes-Benz to avoid damaging the engine cooling system.

- ▶ Refer to the information on coolant (→ page 280).
- ▶ Refill the coolant up to the marker bar ③ in the filler opening of the coolant expansion reservoir ②.
- ▶ Replace cap ① and tighten in a clockwise direction.
- ▶ Start the engine.
- ▶ Set the temperature in the vehicle interior to the maximum output on the control panel of the climate control.
- ▶ After about five minutes, switch off the engine again and allow it to cool down.
- ▶ Check the coolant level again and top up the coolant if necessary.

### Filling up the windscreen washer system

**⚠ WARNING** Risk of fire and injury from windscreen washer concentrate

Windscreen washer concentrate is highly flammable.

- ▶ Avoid fire, naked flames, smoking and the creation of sparks when using windscreen washer concentrate.

**⚠ WARNING** Risk of burns from hot component parts in the engine compartment

Certain component parts in the engine compartment can be very hot, e.g. the engine, the cooler and parts of the exhaust system.

- ▶ Allow the engine to cool down and only touch component parts described in the following.

**! NOTE** Damage to the exterior lighting due to unsuitable windscreen washer fluid

Unsuitable windscreen washer fluids may damage the plastic surface of the exterior lighting.

- ▶ Only use windscreen washer fluids that are also suitable for use on plastic surfaces, e.g. MB SummerFit or MB WinterFit.

### Topping up the washer fluid

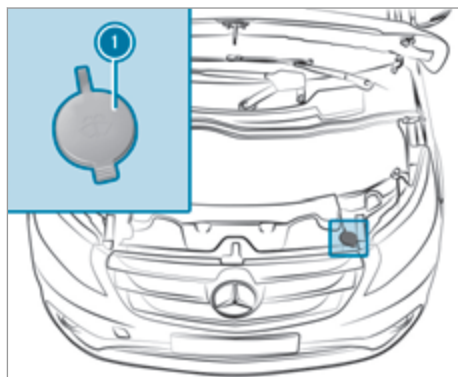

Washer fluid reservoir (example)

- ▶ Observe the notes on windscreen washer fluid (→ page 280).
- ▶ Pull cap ① upwards by the tab.
- ▶ Top up the washer fluid.

- ▶ Push cap  onto the filler opening until it audibly engages.

## Cleaning and care

### Notes on washing the vehicle in an automatic car wash

**⚠ WARNING** Risk of an accident due to reduced braking power after washing the vehicle

Braking efficiency is reduced after washing the vehicle.

- ▶ After the vehicle has been washed, brake carefully while paying attention to the traffic conditions until braking power has been fully restored.

**! NOTE** Damage to the vehicle due to automatic braking

When the following functions are activated, the vehicle brakes automatically in certain situations:

- Active Brake Assist
- Active Distance Assist DISTRONIC
- HOLD function

To avoid damage to the vehicle, deactivate these systems in the following or similar situations:

- ▶ when towing
- ▶ in a car wash

**! NOTE** Damage due to unsuitable car wash

- ▶ Before driving into a car wash make sure that the car wash is suitable for the vehicle dimensions.
- ▶ Ensure there is sufficient ground clearance between the underbody and the guide rails of the car wash.
- ▶ Ensure that the clearance width of the car wash, in particular the width of the guide rails, is sufficient.

To avoid damage to your vehicle, observe the following before using an automatic car wash:

- Active Brake Assist is deactivated.
- Active Distance Assist DISTRONIC is deactivated.

- The HOLD function is switched off.
- The side windows and roof are completely closed.
- The outside mirrors are folded in and an additional antenna is removed, if present.
- The climate control blower is switched off.
- The windscreen wiper switch is in position .

If the vehicle is very dirty, wash off excess dirt before cleaning the vehicle in an automatic car wash.

After leaving the car wash, pay attention to the following:

- The outside mirrors are fully folded out again and an additional antenna is mounted again, if present.
- Remove wax residues on the windscreen and wiper rubbers to prevent smearing and reduce wiper noise.

Remove wax residues from the camera lens in vehicles with a reversing camera (→ page 235).

### Notes on use of a high-pressure cleaner

**⚠ WARNING** Risk of an accident when using high-pressure cleaners with round-spray nozzles

The water jet can cause externally invisible damage.

Components damaged in this way may unexpectedly fail.

- ▶ Do not use a high-pressure cleaner with round-spray nozzles.
- ▶ Have damaged tyres or chassis parts replaced immediately.

**! NOTE** Damage to component parts due to improper high-pressure cleaning

Components can be damaged if the distance of the high-pressure nozzle is too small.

- ▶ Maintain a minimum distance of about 30 cm between the high-pressure nozzle and car parts.
- ▶ Do not use a high-pressure cleaner with a round-spray nozzle.
- ▶ Keep the water jet moving constantly while cleaning.

▶ Do not clean the following components with the high-pressure cleaner:

- electrical components
- plug connectors
- reversing camera
- drivetrain
- seals
- hoses

**!** **NOTE** Damage caused by the use of a high-pressure cleaner in the vehicle interior

The pressurised water created by the high-pressure cleaner and the associated spray could cause considerable damage to the vehicle.

▶ Never use a high-pressure cleaner in the vehicle interior.

**!** **NOTE** Damage to the emissions control system due to improper cleaning

Cleaning the system when it is warm or the direct effect of water jets in the exhaust pipe can damage the emissions control system.

- ▶ Clean the system only when it is cold.
- ▶ Do not direct the water jet into the exhaust pipe.

## Washing the engine

**!** **NOTE** Damage and malfunctions due to washing the engine

- ▶ To prevent damage and malfunctions of the engine, observe the following points:
  - when using high-pressure or steam cleaners, do not point the water jet directly at electrical components and the end of electric cables.
  - make sure that no water enters the vent and ventilation openings.
  - use preservative agents in the engine after washing the engine.
  - protect the belt drive from preservation agents.

## Washing the vehicle by hand

Observe the legal requirements, e.g. in a number of countries, washing by hand is only permitted in specially designated wash bays.

- ▶ Wash the vehicle with lukewarm water and a soft car sponge. When doing so, do not expose the vehicle to direct sunlight.
- ▶ Use a mild cleaning agent, e.g. a Mercedes-Benz approved car shampoo.
- ▶ Carefully spray the vehicle with water and dry off with a leather cloth. Do not point the water jet directly into the air inlet grille.

When operating the vehicle in winter, remove all traces of road salt deposits carefully and as soon as possible.

## Notes on care of paint and matt finish

**!** **NOTE** Paintwork damage and corrosion due to inadequate care

Failure to promptly and thoroughly remove dirt from bird droppings or other residue could result in paintwork damage and corrosion at a later date.

- ▶ Clean dirt off paint and matt finish thoroughly and as soon as possible.

Observe the notes on cleaning and care to avoid paintwork damage.

### Paint

- Insect remains: soak with insect remover and then wash off.
- Bird droppings: soak with water and then wash off.
- Tree resin, oils, fuels and greases: remove by rubbing gently with a cloth soaked in petroleum ether or lighter fluid.
- Coolant and brake fluid: remove with a moist cloth and clean water.
- Tar stains: use tar remover.
- Wax: use silicone remover.
- Do not affix stickers, films or similar.
- Remove dirt as soon as possible.

### Matt finish

- Only use care products approved for Mercedes-Benz.
- Do not polish the vehicle and light-alloy wheels.

- Use only automatic car washes that meet current technological standards.
- Do not use a wash program that ends with a hot wax treatment in automatic car washes.
- Do not use paint cleaners, buffing or polishing products, gloss preservers, e.g. wax.
- Always have paintwork repairs carried out at a qualified specialist workshop.

### Notes on the care of vehicle parts

**⚠ WARNING** Risk of injury if unsuitable climbing aids are used

In the event that you use openings in the bodywork or attachments as steps, you could:

- Slip and/or fall.
- Damage the vehicle and thus slip and fall.

▶ Always use non-slip, stable climbing aids, e.g. a suitable ladder.

**⚠ WARNING** Risk of entrapment if the windscreen wipers are switched on while the windscreen is being cleaned

If the windscreen wipers are set in motion while you are cleaning the windscreen or wiper blades, you can be trapped by the wiper arm.

▶ Always switch off the windscreen wipers and the ignition before cleaning the windscreen or wiper blades.

**⚠ WARNING** Risk of burns from the tailpipe and tailpipe trims

The exhaust tailpipe and tailpipe trims can become very hot. If you come into contact with these parts of the vehicle, you could burn yourself.

▶ Always be particularly careful around the tailpipe and the tailpipe trims and supervise children especially closely in this area.

▶ Allow vehicle parts to cool down before touching them.

**!** **NOTE** Damage caused by the use of openings in the bodywork or detachable part as a step

Using the lower guide of the sliding door (carriage) as a step can damage the trim and/or mechanism of the sliding door.

▶ Do not use the guide of the sliding door (carriage) as a step.

**i** Information on suitable cleaning agents or cleaning cloths can be obtained from a qualified specialist workshop.

To prevent damage to the vehicle, observe the notes for cleaning and care of the following vehicle parts:

#### Wheels and rims

- Use water and acid-free alloy wheel cleaner.
- Do not use acidic alloy wheel cleaners to remove brake dust. Otherwise, wheel bolts and brake components could be damaged.
- To avoid corrosion of brake discs and brakepads, drive for a few minutes after cleaning before parking the vehicle. The brake discs and brakepads warm up and dry out.

#### Windows

- Clean the windows inside and outside with a damp cloth and with a cleaning agent recommended for Mercedes-Benz.
- Do not use dry cloths, abrasive cleaning agents or cleaners containing solvents to clean the inside of windows.

#### Wiper blades

- With the wiper arms folded away, clean the wiper blades with a damp cloth (→ page 120).
- Do not clean the wiper blades too often.

#### Exterior lighting

- Clean the lenses with a wet sponge and mild cleaning agent, for example, car shampoo.
- Only use cleaning agents or cloths suitable for plastic lenses.

#### Sensors

- Clean the sensors in the front and rear bumpers with a soft cloth and car shampoo (→ page 154).
- When using a high-pressure cleaner, keep a minimum distance of 30 cm.

**Reversing camera and 360° Camera**

- Open the camera cover with the multimedia system (→ page 170).
- Use clean water and a soft cloth to clean the camera lens.
- Do not use a high-pressure cleaner.

**Sliding door**

- Remove foreign objects from the vicinity of the contact plates and contact pins of the sliding door.
- Clean the contact plates and contact pins with a mild cleaning agent and a soft cloth.
- Do not oil or grease the contact plates and the contact pins.

**Tailpipes**

- Clean with a cleaning agent recommended for Mercedes-Benz, especially in the winter and after washing the vehicle.
- Do not use acidic cleaning agents.

**Trailer hitch**

- Observe the notes on care in the trailer hitch manufacturer's operator's manual.
- Do not clean the ball neck with a high-pressure cleaner or solvent.
- Remove traces of rust on the ball, for example, with a wire brush.
- Remove dirt with a lint-free cloth.
- After cleaning, lightly oil or grease the ball head.

-  Before using trailers with anti-swerve coupling, note the manufacturer's operator's manual.

**Notes on the cleaning and care of the interior**

 **WARNING** Risk of injury from plastic parts breaking off after the use of solvent-based care products

Care and cleaning products containing solvents can cause surfaces in the cockpit to become porous. When the airbags are deployed, plastic parts may break away.

- ▶ Do not use any care or cleaning products containing solvents to clean the cockpit.

 **WARNING** Risk of injury or fatal injuries from bleached seat belts

Bleaching or dyeing seat belts can severely weaken them.

This can, for example, cause seat belts to tear or fail in an accident.

- ▶ Never bleach or dye seat belts.

 **NOTE** Property damage due to disinfectants

The interior includes a number of sensitive surfaces such as displays, plastics and leather.

Disinfectants can contain alcohol and other substances that penetrate and damage surfaces. Technology behind buttons and displays can also be damaged.

- ▶ Do not use disinfectant on interior surfaces.

To prevent damage to the vehicle, observe the following notes for cleaning and care:

**Seat belts**

- Clean with lukewarm soapy water.
- Do not use chemical cleaning agents.
- No heating over 80°C or drying in direct sunlight.

**Instrument cluster lenses**

- Clean the surfaces carefully with a microfibre cloth and acrylic glass care product.
- Do not use any other agents.

**Display**

- Switch off the display and let it cool down.
- Clean the surface carefully with a microfibre cloth and a suitable display cleaning product (TFT-LCD).
- Do not use any other agents.

**Digital inside rearview mirror**

- Clean the mirror glass with a cloth moistened with glass cleaner.
- Clean the light sensors of the inside rearview mirror with a dry cotton cloth.
- Do not spray the glass cleaner on the mirror glass.
- Do not use any other agents.

**Plastic trim**

- Clean with a damp microfibre cloth.
- For heavy soiling: Use a cleaning product recommended for Mercedes-Benz.
- Do not affix stickers, films or similar.
- Do not allow to come into contact with cosmetics, insect repellent and sun creams.

**Roof lining**

- Clean with a brush or dry shampoo.

**Carpet**

- Use a carpet and textile cleaning agent recommended for Mercedes-Benz.

**Genuine leather seat covers**

- Clean with a damp cloth and then wipe with a dry cloth.
- Leather care: Use a leather care agent recommended for Mercedes-Benz.
- Do not allow the leather to become too damp.
- Do not use a microfibre cloth.

**Imitation leather seat covers**

- Clean with a damp cloth and 1% soapy water.
- Do not use a microfibre cloth.

**Cloth seat covers**

- Clean with a damp microfibre cloth and 1% soap solution and allow to dry.

**Steering wheel from genuine leather or DINAMICA****! NOTE** Damage caused by wrong cleaners

- ▶ Do not use solvent-based cleaning agents such as tar remover or wheel cleaner; neither should you use polishes or waxes. Otherwise you may damage the finish.

- Clean with a damp cloth and a 1% soapy water solution and then wipe with a dry cloth.
- For heavy soiling: Use a cleaning product recommended for Mercedes-Benz.
- Leather care: Use a leather care agent recommended for Mercedes-Benz.
- Do not allow the leather to become too damp.
- Do not use a microfibre cloth.

- ⓘ Leather is a natural product. It has natural surface properties, such as differences in structure, marks caused by growth and injury or subtle colour differences.

**Real wood and trim elements**

- Clean with a microfibre cloth.
- Black piano-lacquer look: Clean with a damp cloth and soapy water.
- For heavy soiling: Use a cleaning product recommended for Mercedes-Benz.
- Do not use any cleaning agents, polishes or waxes containing solvents containing solvents.

## Emergency

### Removing the safety vest

The safety vest is located in the door stowage compartment in the driver's door.

- ▶ Take the safety vest out of the door stowage compartment.
- ① Safety vests can also be stored in the door stowage compartment of the co-driver's door.

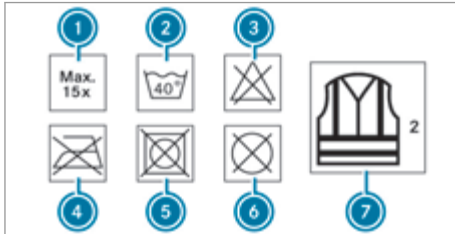

- ① Maximum number of washes
- ② Maximum wash temperature
- ③ Do not bleach
- ④ Do not iron
- ⑤ Do not tumble dry
- ⑥ Do not dry-clean
- ⑦ This is a class 2 vest

The safety vest only fulfils the legally required standards if it is the correct size and is completely closed.

Replace the safety vest in the following cases:

- if damaged or if the reflex strips are dirty
- if the maximum permitted number of washes is exceeded
- if the safety vest's fluorescence has faded

### Warning triangle

#### Removing the warning triangle

The warning triangle is located in the stowage compartment in the driver's door.

- ▶ Take the warning triangle out of the stowage compartment.

### Setting up the warning triangle

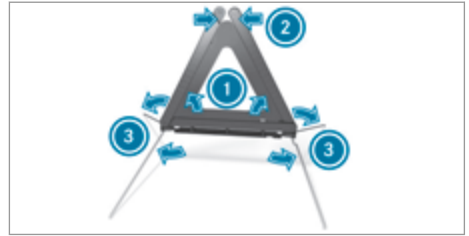

- ▶ Fold side reflectors ① upwards to form a triangle and lock them at the top using upper press-stud ②.
- ▶ Fold stand ③ down and out to the side.
- ① When using the warning triangle you must observe the legal requirements for the country in which you are currently driving.

### Removing the first-aid kit (soft sided)

The first-aid kit (soft sided) is located in the stowage compartment in the co-driver door.

- ▶ Remove first-aid (soft sided) kit from the stowage compartment.

Check the expiry date on the first-aid kit (soft sided) at least once a year. Replace any expired or missing contents.

Observe the legal requirements of the country in which you are currently driving.

### Removing the fire extinguisher

**⚠ WARNING** Risk of accident due to an incorrectly secured fire extinguisher in the driver's footwell

A fire extinguisher may impede pedal travel or block a depressed pedal.

This jeopardises the operating and road safety of the vehicle.

The fire extinguisher can be flung around and injure the driver or other vehicle occupants.

- ▶ Always store and secure the fire extinguisher in the bracket.
- ▶ Do not remove the fire extinguisher while driving.

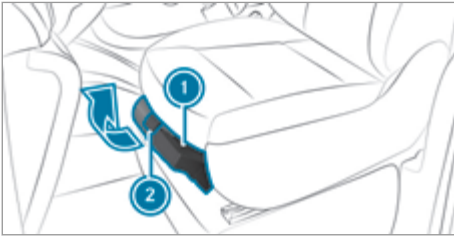

- ▶ Open the clasp of holder ②.
- ▶ Remove fire extinguisher ① from its holder.

For vehicles with a swivelling front seat, the retainer with the fire extinguisher is located at the side of the seat base.

Please read the instructions on the fire extinguisher carefully and familiarise yourself with its operation. Have the fire extinguisher refilled after each use and checked every one or two years. It may otherwise fail in an emergency.

Observe the legal requirements of the country in which you are currently driving.

### Mercedes-Benz emergency call system

#### Information on the Mercedes-Benz emergency call system

The Mercedes-Benz emergency call system only functions in areas where mobile phone coverage is available from the relevant contract partner. Insufficient network coverage from the relevant contract partner may result in an emergency call not being transmitted.

The ignition must be switched on before an automatic emergency call can be made.

- ① The Mercedes-Benz emergency call system is activated at the factory. Using the Mercedes-Benz emergency call system is free of charge.

#### Overview of the Mercedes-Benz emergency call system

The Mercedes-Benz emergency call system can help to decisively reduce the time between an accident and the arrival of emergency services at the site of the accident. It helps locate an accident site in places that are difficult to access.

The emergency call can be triggered automatically (→ page 239).

You also have the option of triggering the emergency call manually (→ page 240). Only make

emergency calls if you or others are in need of rescue. Do not make an emergency call in the event of a breakdown or a similar situation.

#### Message in the media display:

**SOS NOT READY:** the vehicle is not switched on or the emergency call system is malfunctioning.

This does not necessarily indicate a total failure of the emergency call system. Emergency calls can still be transmitted.

The display refers only to the vehicle and does not take account of the availability of mobile phone networks and the Mercedes-Benz emergency call centre.

The functional readiness of the emergency call system on the vehicle can be seen when the **SOS NOT READY** display disappears once the vehicle is switched on.

During an active emergency call, **SOS** appears in the display.

You can find more information on the regional availability of the Mercedes-Benz emergency call system at: <https://www.mercedes-benz-mobile.com/extra/ecall/>

- ① If no emergency call is available due to a technical problem in the vehicle, the red **SOS NOT READY** message appears in the display of the instrument cluster or in the media display and the red LED indicator lights up.

#### Triggering an automatic Mercedes-Benz emergency call

##### Requirements:

- The vehicle is switched on.
- The starter battery is sufficiently charged.

The Mercedes-Benz emergency call system automatically triggers an emergency call after activation of the restraint system in the event of an accident, for example airbags or seat belt tensioners.

When the emergency call is made:

- A voice connection is made to the Mercedes-Benz emergency call centre.
- A message with accident data is transmitted to the Mercedes-Benz emergency call centre.  
The Mercedes-Benz emergency call centre can transmit the vehicle position data to one of the public emergency services call centres.
- Under certain circumstances data is also transmitted in the voice channel to the Mercedes-Benz emergency call centre.

This allows measures for rescue, recovery or towing to a Mercedes-Benz Service Centre to be initiated quickly.

The SOS button in the overhead control panel flashes until the emergency call is finished.

It is not possible to immediately end an automatic emergency call.

If the Mercedes-Benz emergency call system cannot connect to the Mercedes-Benz emergency call centre, the emergency call is automatically sent to the public emergency services call centre.

If no connection can be made to the public emergency services, a corresponding message appears in the display.

▶ Dial the emergency number **112** on your mobile phone.

If an emergency call has been initiated:

- Remain in the vehicle if the road and traffic conditions permit you to do so until a voice connection is established with the emergency call centre operator.
- Based on the call, the operator decides whether it is necessary to call rescue teams and/or the police to the accident site.
- If no vehicle occupant answers, an ambulance is sent to the vehicle immediately.

### Triggering a manual Mercedes-Benz emergency call

▶ **To use the SOS button in the overhead control panel:** press the SOS button at least one second long (→ page 194).

▶ **To use voice control:** use the LINGUATRONIC "Call the Mercedes accident centre" voice command.

When the emergency call is made:

- A voice connection is made to the Mercedes-Benz emergency call centre.
- A message with accident data is transmitted to the Mercedes-Benz emergency call centre.  
The Mercedes-Benz emergency call centre can transmit the vehicle position data to one of the public emergency services call centres.
- Remain in the vehicle if the road and traffic conditions permit you to do so until a voice connection is established with the emergency call centre operator.

- Based on the call, the operator decides whether it is necessary to call rescue teams and/or the police to the accident site.
- Under certain circumstances data is also transmitted in the voice channel to the Mercedes-Benz emergency call centre.

This allows measures for rescue, recovery or towing to a Mercedes-Benz service centre to be initiated quickly.

If the Mercedes-Benz emergency call system cannot connect to the Mercedes-Benz emergency call centre, the emergency call is automatically sent to the public emergency services call centre.

If no connection can be made to the public emergency services, a corresponding message appears in the media display.

▶ Dial the emergency number **112** on your mobile phone.

### Ending an unintentional Mercedes-Benz emergency call

▶ Select  on the multifunction steering wheel.

### Transmitted data Mercedes-Benz with the Mercedes-Benz emergency call

In the event of an automatic or manual emergency call, as well as for a **112** emergency call, data is transmitted to the Mercedes-Benz emergency call centre or the public emergency services call centre.

The following data is transmitted:

- Vehicle's GPS position data
- GPS position data on the route (a few 100 m before the incident)
- Direction of travel
- Vehicle identification number
- Vehicle drive type
- Estimated number of people in the vehicle
- Whether the emergency call was initiated manually or automatically
- Time of the accident
- Language setting on the multimedia system

For accident clarification purposes, the following measures can be taken up to an hour after the emergency call has been initiated:

- The current vehicle position can be called up.
  - A voice connection to the vehicle occupants can be established.
- i** **For Eurasian Economic Union:** various functions, e.g. receiving traffic information, cannot be used for up to two hours after sending an emergency call.

### Function of the emergency call system self-diagnosis

Your car verifies the operability of the emergency call system each time the ignition is ON.

In the event of a system malfunction, you will be informed by the following signals:

- The **SOS NOT READY** message in the instrument cluster or the red **SOS NOT READY** message on the display, if available
- The flashing indicator lamp in the overhead control panel



Please, make sure, that during 30 seconds after switching ignition ON the red indicator **SOS NOT READY** in the upper right corner of the multimedia display is switched OFF, this means the emergency call system passed diagnostics successfully.

### Starting/stopping ERA-GLONASS test mode

#### Requirements:

- The starter battery is sufficiently charged.
- The vehicle is switched on.
- The vehicle has been stationary for at least one minute.

**i** The test mode is currently available in the countries of the Eurasian Economic Union.

▶ **To start the test mode:** press and hold the  button on the multifunction steering wheel or the  button on the overhead control panel for at least five seconds. Test mode is started and ended automatically after completion of the speech test.

▶ **To stop test mode manually:** switch off the vehicle. The test mode is ended.

### Flat tyre

#### Notes on flat tyres

**⚠ WARNING** Risk of accident due to a flat tyre

A flat tyre strongly impairs the vehicle's driving characteristics, as well as its steering and braking characteristics.

- ▶ Do not drive with a flat tyre.
- ▶ Replace the flat tyre with the spare wheel. Alternatively, consult a qualified specialist workshop.

You will find a sticker with the Mercedes-Benz Service24h telephone number on the B-pillar on the driver's side, for example.

For vehicles with a spare wheel, information in the event of a flat tyre can be found under "Wheels and tyres" (→ page 261).

### Battery

#### Notes on the starter battery

Work on the battery, e.g. removing or installing, requires specialist knowledge and the use of special tools. Therefore, always have work on the battery carried out at a qualified specialist workshop.

**⚠ WARNING** Risk of an accident due to work carried out incorrectly on the battery

Work carried out incorrectly on the battery can, for example, lead to a short circuit. This can restrict functions relevant for safety systems and impair the operating safety of your vehicle.

You could lose control of the vehicle in the following situations in particular:

- when braking
  - in the event of abrupt steering manoeuvres and/or when the vehicle's speed is not adapted to the road conditions
- ▶ In the event of a short circuit or a similar incident, contact a qualified specialist workshop immediately.
  - ▶ Do not drive on.
  - ▶ Always have work on the battery carried out at a qualified specialist workshop.

- Further information on ABS (→ page 155)
- Further information on ESP® (→ page 155)

For safety reasons, Mercedes-Benz recommends that you only use batteries which have been approved for your vehicle by Mercedes-Benz. These batteries provide increased impact protection to prevent vehicle occupants from suffering acid burns should the battery be damaged in an accident.

**⚠ WARNING** Risk of explosion due to electrostatic charge

Electrostatic charge can ignite the highly explosive gas mixture in the battery.

- ▶ To discharge any electrostatic charge that may have built up, touch the metal vehicle body before handling the battery.

The highly flammable gas mixture is created while the battery is charging and when jump-starting. Make sure that neither you nor the battery is electrostatically charged.

Electrostatic charge can occur in the following cases, for example:

- you are wearing synthetic clothing.
- there is friction between your clothing and the seat.
- if you drag or push the battery across a carpet or other synthetic materials
- you rub the battery with cloths or towels

**⚠ WARNING** Danger of chemical burns from the battery acid

Battery acid is caustic.

- ▶ Avoid contact with the skin, eyes or clothing.
- ▶ Do not lean over the battery.
- ▶ Do not inhale battery gases.
- ▶ Keep children away from the battery.
- ▶ Immediately rinse battery acid off thoroughly with plenty of clean water and seek medical attention immediately.



**ENVIRONMENTAL NOTE** Environmental damage due to improper disposal of batteries



Batteries contain pollutants. It is illegal to dispose of them with the household rubbish.



Dispose of batteries in an environmentally responsible manner. Take discharged batteries to a qualified specialist workshop or to a collection point for used batteries.

Observe the safety notes and protective measures when handling batteries.



Risk of explosion



Fire, naked flames and smoking are prohibited when handling the battery. Avoid creating sparks.



Electrolyte or battery acid is corrosive. Avoid contact with the skin, eyes and clothing. Wear suitable protective clothing, in particular gloves, an apron and a safety mask. Immediately rinse electrolyte acid splashes off with clean water. If necessary, seek medical advice.



Wear eye protection.



Keep children at a safe distance.



Observe these Operating Instructions.

Observe the following notes:

- Recharge the battery more frequently in the following cases:
  - You predominantly drive short distances.
  - You predominantly drive at low outside temperatures.
  - You leave the vehicle parked for a lengthy period.

In order for the batteries to achieve their maximum possible service life, they must always be sufficiently charged.

- Consult a qualified specialist workshop if you wish to leave your vehicle parked up for long periods.
- When you park the vehicle, remove the key if you do not require any electrical consumers. The vehicle will then use very little energy, thus conserving battery power.
- If your vehicle requires jump-starting, or if you wish to provide jump-starting assistance to another vehicle, only use the jump-start connection point in the engine compartment (→ page 243).

### Installation locations

Your vehicle may be equipped with the following two batteries located in the seat base of the right-hand front seat, depending on the equipment version:

- Starter battery
- Support battery

### Starting assistance and charging the 12 V battery

**⚠ WARNING** Risk of explosion from a frozen battery

A discharged battery may freeze at temperatures slightly above or below freezing point.

During starting assistance or battery charging, battery gas can be released.

- ▶ Always allow a battery to thaw before charging it or performing starting assistance.

If the warning/indicator lamps do not light up in the instrument cluster at temperatures around or below freezing, it is highly probable that the discharged battery has frozen.

In this case, observe the following points:

- Do not give the vehicle starting assistance or charge the battery.
- The service life of a battery that has been thawed may be reduced drastically.
- The starting behaviour may deteriorate, particularly at low temperatures.
- It is recommended that you have a thawed battery checked at a qualified specialist workshop.

**⚠ WARNING** Risk of explosion due to explosive mixture of gases

An explosive mixture of gases can escape from the battery during charging and starting assistance.

- ▶ Fire, naked flames, smoking and creating sparks must be avoided.
- ▶ Make sure there is adequate ventilation.
- ▶ Do not stand over the battery.

**⚠ WARNING** Danger of chemical burns from the battery acid

Battery acid is caustic.

- ▶ Avoid contact with the skin, eyes or clothing.
- ▶ Do not lean over the battery.
- ▶ Do not inhale battery gases.
- ▶ Keep children away from the battery.
- ▶ Immediately rinse battery acid off thoroughly with plenty of clean water and seek medical attention immediately.

### Starting assistance

**⚠ NOTE** Damage caused by numerous or extended attempts to start the engine

Numerous or extended attempts to start the engine may damage the catalytic converter due to non-combusted fuel.

- ▶ Avoid numerous and extended attempts to start the engine.

Do not use a rapid charging device to start the vehicle. If your vehicle's battery is discharged, the engine can be jump-started from another vehicle or from a donor battery using jump leads. For this purpose, the vehicle has a jump-start connection point in the engine compartment.

When jump-starting, observe the following points:

- The battery is not accessible in all vehicles. If the other vehicle's battery is not accessible, starting assistance is to be provided using a donor battery or a starting assistance device.
- You may only jump-start the vehicle when the engine and exhaust system are cold.
- If the battery is frozen, do not start the vehicle. Let the battery thaw first.
- Starting assistance may only be provided using batteries with a nominal voltage of 12 V.
- Only use jump leads that have a sufficient cross-section and insulated terminal clamps.
- If the battery is fully discharged, attach the donor battery for a few minutes before attempting to start. This charges the discharged battery a little.
- Make sure that the two vehicles do not touch.

Jump leads and further information regarding starting assistance can be obtained at any qualified specialist workshop.

Ensure the following before connecting the jump lead:

- The jump leads are not damaged.
- Parts of the terminal clamps which are not insulated do not come into contact with other metal parts while the jump leads are connected to the battery.
- The jump leads do not touch moving parts when the vehicle is started, such as the V-belt pulley or the fan.

- ▶ Apply the parking brake.
- ▶ **Vehicles with automatic transmission:** shift the transmission to position **P**.
- ▶ **Vehicles with manual transmission:** shift to neutral.
- ▶ Switch off all electrical consumers, e.g. audio equipment, blower.
- ▶ Switch off the vehicle and remove the key.
- ▶ Open the bonnet (→ page 227).

### Connecting and disconnecting the jump lead

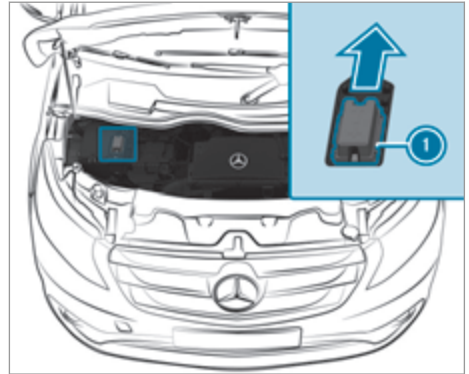

Example: jump-start connection point

- ▶ Push contact protection cover ① of the jump-start connection point towards the rear of the vehicle against the spring pressure as far as it will go. Positive terminal ⑤ of the jump-start connection point is visible.

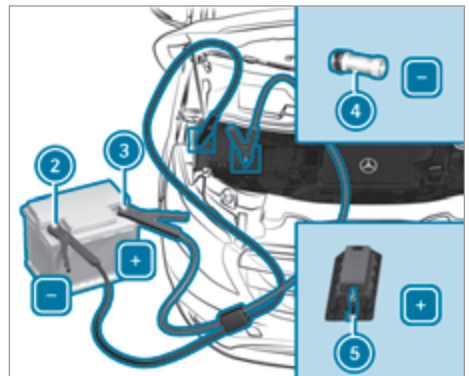

Terminal connection diagram

- ▶ Remove the cover from positive terminal ③ of the donor battery.
- ▶ Connect the positive terminal clamp of the jump lead to positive terminal ③ of the donor battery, and then to positive terminal ⑤ of the jump-start connection point.
- ▶ Connect the negative terminal clamp of the jump lead to negative terminal ② of the donor battery, and then to earth contact ④ of your own vehicle.

- ▶ Start the engine of the donor vehicle and run it at idling speed.
- ▶ Start the vehicle and let the engine run for a while.
- ▶ Before disconnecting the jump leads, switch on an electrical consumer in your own vehicle, e.g. the rear window heater or the lighting.
- ▶ Disconnect the negative terminal clamp of the jump lead from earth contact ④ and then from negative terminal ② of the donor battery.
- ▶ Disconnect the positive terminal clamp of the jump lead from positive terminal ⑤ on the jump-start connection point, and then from positive terminal ③ of the donor battery. Contact protection cover ① is automatically returned forwards to its original position by the spring force and the jump-start connection point is closed.
- ▶ Position the cover on positive terminal ③ of the donor battery.
- ▶ Have the battery checked at a qualified specialist workshop.

### Charging the 12 V battery

**!** **NOTE** Damage to the electronics due to unapproved chargers

If you charge an installed battery with a charger not approved for Mercedes-Benz, the on-board electronics can be damaged.

- ▶ Only use a charger approved for Mercedes-Benz which permits charging in the installed condition.
- ▶ Only charge the battery via the jump-start connection point.

A battery charger specially adapted for Mercedes-Benz vehicles and tested and approved for Mercedes-Benz is available as an accessory.

Further information is available from any Mercedes-Benz Service Centre. Read the operating instructions for your charger before charging the battery.

Recharge the battery more frequently if you use the vehicle mainly for short trips and/or drive at low outside temperatures.

- ▶ Connect the battery charger to the positive terminal and earth contact in the same order as when connecting the donor battery in the jump-starting procedure.

- i** If a battery is not fitted and not in service, you should charge it every three months. This helps to counteract self-discharging and prevent damage to the battery.

### 12 V battery care

**!** **NOTE** Battery discharge due to leakage currents

Dirty battery terminal clamps and battery surfaces cause leakage currents. This can lead to the battery discharging.

- ▶ Keep the battery terminals and battery surfaces clean and dry.

**!** **NOTE** Damage to the battery housing due to improper cleaning

If you use cleaning agents containing fuel, these can damage the battery housing.

- ▶ Do not use cleaning agents containing fuel.

**!** **NOTE** Damage to the battery due to self-discharge

If dirt gets into the battery cell, the self-discharge of the battery is increased and the battery can be damaged.

- ▶ Only clean the battery with the cell caps screwed in.

Observe the following points on battery care:

- ▶ Regularly check the battery terminals and the fastening of the negative cable to the chassis to ensure that they are firmly seated.
- ▶ Lightly grease the undersides of the battery terminal clamps with acid-resistant grease.
- ▶ Only clean the battery housing with commercially available cleaning agents.

### Disconnecting and removing the starter battery

**!** **WARNING** Risk of explosion due to the ignition of hydrogen gas

If there is a short circuit or sparks are created, there is a danger of hydrogen gas igniting when you charge the battery.

- ▶ Make sure that the POSITIVE terminal of a connected battery does not come into contact with vehicle parts.

- ▶ Never place metal objects or tools on a battery.
- ▶ When connecting and disconnecting the battery, always observe the sequence of battery terminals described.
- ▶ During starting assistance, always take care to connect only battery terminals of identical polarity.
- ▶ During starting assistance, observe the sequence described for connecting and disconnecting the jump leads.
- ▶ Do not connect or disconnect the battery terminals with the engine running.

**⚠ WARNING** Danger of chemical burns from the battery acid

Battery acid is caustic.

- ▶ Avoid contact with the skin, eyes or clothing.
- ▶ Do not lean over the battery.
- ▶ Do not inhale battery gases.
- ▶ Keep children away from the battery.
- ▶ Immediately rinse battery acid off thoroughly with plenty of clean water and seek medical attention immediately.

**! NOTE** Damage to electronic components due to work carried out incorrectly on the battery

If the starter battery is disconnected before the key is removed from the ignition lock, electronic components or assemblies, such as the alternator, can be damaged.

- ▶ Switch off the vehicle and remove the key from the ignition lock.
- ▶ Check to see that there are no indicator lamps lit in the instrument cluster.
- ▶ Always disconnect the negative clamp first and then the positive clamp.
- ▶ Do not interchange the battery clamps.

Always have work on the battery carried out at a qualified specialist workshop.

If, in exceptional circumstances, you must disconnect the battery yourself, pay attention to the following:

- Observe the notes on the 12 V battery (→ page 241).
- Secure the vehicle to prevent it from rolling away.
- After the battery has been disconnected, the parking brake is automatically applied. You can then no longer move the vehicle.
- For vehicles with an automatic transmission, the transmission is locked in position **P** after disconnecting the battery. You can then no longer move the vehicle.
- The battery and the cover of the positive terminal clamp must be fitted securely during operation.

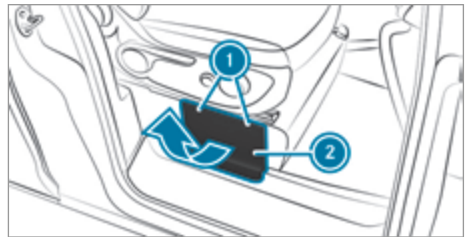

Seat base (example: right-hand front seat)

The following description on connecting and fitting the battery uses the example of the starter battery in the seat base of the right-hand front seat.

- ▶ Switch off all electrical consumers.
- ▶ Switch off the vehicle and remove the key from the ignition lock.
- ▶ Open the front right-hand door.
- ▶ Press both catch springs **1** down and remove cover **2** upwards from the seat base.
- ▶ Remove cover **2** by pulling upwards at an angle from the seat base.

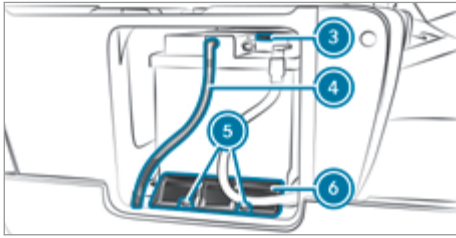

Open seat base (example: right-hand front seat)

- ▶ Remove screws ⑤ from holder ⑥.
- ▶ Remove holder ⑥.
- ▶ Remove vent hose ④ from the top of the battery.
- ▶ Pull the battery out of the seat base until the negative terminal clamp can be released and removed.
- ▶ Disconnect the negative terminal clamp from negative terminal ③.
- ▶ Remove the negative terminal clamp in such a way that the battery terminal clamp no longer touches negative terminal ③.

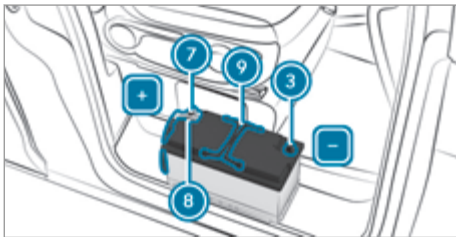

Example: starter battery

- ▶ Remove the battery from the seat base and place it on the door sill as shown. If necessary, hold the battery by handles ⑨.
- ▶ Remove the clamp cover of positive terminal ⑧.
- ▶ Remove positive terminal clamp ⑧ from positive terminal ⑦.
- ▶ Remove positive clamp ⑧ in such a way that it no longer touches positive terminal ⑦.
- ▶ Lift the battery out of the door sill by handles ⑨.

## Connecting and fitting the starter battery

**⚠ WARNING** Risk of explosion due to the ignition of hydrogen gas

If there is a short circuit or sparks are created, there is a danger of hydrogen gas igniting when you charge the battery.

- ▶ Make sure that the POSITIVE terminal of a connected battery does not come into contact with vehicle parts.
- ▶ Never place metal objects or tools on a battery.
- ▶ When connecting and disconnecting the battery, always observe the sequence of battery terminals described.
- ▶ During starting assistance, always take care to connect only battery terminals of identical polarity.
- ▶ During starting assistance, observe the sequence described for connecting and disconnecting the jump leads.
- ▶ Do not connect or disconnect the battery terminals with the engine running.

**! NOTE** Damage to the on-board electronics due to reversing the battery clamps

Incorrectly connecting the battery can damage the on-board electronics.

- ▶ Always connect the battery as described in the following sequence. Never reverse the terminal clamps.

The following description on connecting and fitting the battery uses the example of the starter battery in the seat base of the right-hand front seat.

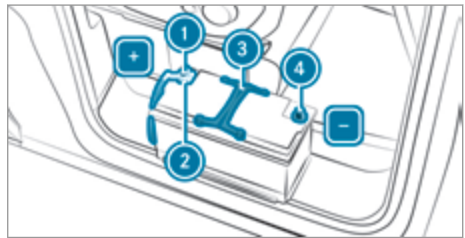

Example: starter battery

- ▶ Place the battery on the door sill as shown and secure with handles ③ if necessary.
- ▶ Connect positive terminal clamp ② to positive terminal ①. The positive lead must be routed

parallel to the side of the battery housing in the connection area, as shown.

- ▶ Place the positive terminal clamp cover on positive terminal ①.
- ▶ Fold both handles ③ down onto the battery.
- ▶ Push the battery into the seat base until the negative terminal clamp can be connected.
- ▶ Connect the negative terminal clamp to negative terminal ④.
- ▶ Push the battery into the seat base as far as it will go.

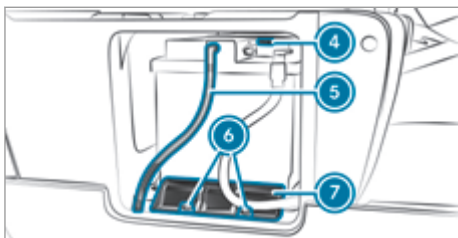

Open seat base with fitted battery (example: right-hand front seat)

- ▶ Connect vent hose ⑤ to the battery connection at the top, beside negative terminal ④.
- ▶ Place holder ⑦ over the lower edge of the battery housing and the threaded holes for screws ⑥.
- ▶ Screw on holder ⑦ with screws ⑥. The battery is secured to prevent slipping.

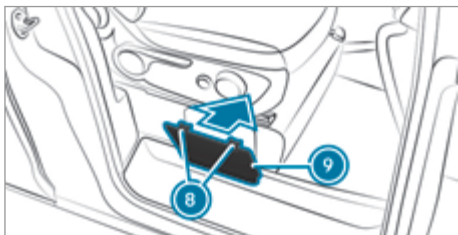

Seat base (example: right-hand front seat)

- ▶ Insert cover ⑨ in front of the battery compartment down into the seat base and close it. Catch springs ⑧ of cover ⑨ should engage audibly.

Carry out the following work after connecting the battery:

- ▶ Reset the side windows (→ page 65).

- ▶ Reset the outside mirrors (→ page 122).
- ▶ Reset the electric sliding doors (→ page 60).
- ▶ Reset the EASY-PACK tailgate (→ page 62).

## Towing or tow-starting

### Overview of permissible towing methods

- ⚠ **WARNING** Risk of accident due to limited safety-related functions during the towing process

Safety-related functions are limited or no longer available in the following situations:

- the vehicle is switched off.
- the brake system or power steering system is malfunctioning.
- the energy supply or the on-board electrical system is malfunctioning.

When your vehicle is towed away, significantly more effort may be required to steer and brake than is normally required.

- ▶ Use a tow bar.
- ▶ Make sure that the steering wheel can move freely before towing the vehicle away.

- ⚠ **WARNING** Risk of accident when towing with steering wheel lock

If the steering wheel lock is engaged, you will not be able to steer the vehicle.

- ▶ When towing with a tow rope or tow bar, always switch on the vehicle.

- ⚠ **WARNING** Risk of accident when towing a vehicle which is too heavy

If the vehicle to be tow-started or towed away is heavier than the permissible gross mass of your vehicle, the following situations can occur:

- the towing eye may become detached.
- the vehicle/trailer combination may swerve or overturn.
- ▶ Before tow-starting or towing away, check if the vehicle to be tow-started or towed away exceeds the permissible gross mass.

Details on the permissible gross vehicle weight of your vehicle can be found on the vehicle identification plate (→ page 273).

**!** **NOTE** Damage to the vehicle due to automatic braking

When the following functions are activated, the vehicle brakes automatically in certain situations:

- Active Brake Assist
- Active Distance Assist DISTRONIC
- HOLD function

To avoid damage to the vehicle, deactivate these systems in the following or similar situations:

- ▶ when towing
- ▶ in a car wash

**!** **NOTE** Damage due to incorrect connection of the tow bar or improper use of the towing device

- ▶ Only connect the tow rope or tow bar to the towing eyes or the trailer tow hitch.
- ▶ Do not use the towing eyes to recover a vehicle.

**!** **NOTE** Damage due to pulling force being too high

Pulling away abruptly can damage the vehicles if the tractive forces are too high.

- ▶ Pull away as straight, slowly and smoothly as possible.

**!** **NOTE** Damage due to improper towing with a tow rope

If you ignore safety and protective measures when towing with a tow rope, this can result in damage to the vehicle.

Observe the following points:

- ▶ Secure the tow rope on the same side on both vehicles.

- ▶ Secure the tow rope to the towing eyes.
- ▶ Do not exceed the legally prescribed length of the tow rope.
- ▶ Mark the tow rope in the middle, e.g. with a white cloth (30 x 30 cm). This will make other road users aware that a vehicle is being towed.
- ▶ During the journey, observe the brake lamps of the towing vehicle and maintain the distance so that the tow rope does not sag.
- ▶ Do not use steel cables or chains to tow your vehicle.

**!** **NOTE** Damage due to towing the vehicle at too high a speed or too far

Towing the vehicle at too high a speed or too far can damage the drivetrain.

- ▶ Do not exceed a towing speed of 50 km/h.
- ▶ Do not exceed a towing distance of 50 km.

**!** **NOTE** Damage to the automatic transmission when towing due to shifting into transmission position **P**

If you open the driver's or co-driver's door when towing, it can lead to the automatic transmission shifting to position **P** and becoming damaged.



- ▶ Shift the automatic transmission to position **N**.
- ▶ Do not open any doors during the towing process.

When towing away, you must observe the legal requirements for the country in which you are currently driving.

In the event of a breakdown, Mercedes-Benz recommends that you have the vehicle transported instead of towed.

Have the vehicle transported on a transporter or trailer if it has transmission damage.

## Permissible towing methods

	 Both axles on the ground	 Front axle raised	 Rear axle raised
Vehicles with manual transmission	Yes, no further than 50 km at 50 km/h	No	Yes, if the steering wheel is fixed in the centre position with a steering wheel lock. Maximum 50 km at 50 km/h
Vehicles with automatic transmission	Yes, no further than 50 km at 50 km/h	No	Yes, if the steering wheel is fixed in the centre position with a steering wheel lock. Maximum 50 km at 50 km/h
Vehicles with all-wheel drive (4MATIC)	Yes, no further than 50 km at 50 km/h	No	No

**i** If the transmission cannot be shifted to position **N**, have the vehicle transported (→ page 251). A towing vehicle with lifting equipment is required for vehicle transport.

### Towing the vehicle with both axles on the ground

- ▶ Observe the notes on permissible towing methods (→ page 248).
- ▶ Make sure that the battery is connected and charged.

If the battery is discharged, observe the following points:

- The vehicle cannot be switched on.
- It is not possible to release or apply the electric parking brake.
- The transmission cannot be shifted to position **N**.

### Vehicles with manual transmission

- ▶ Switch on the hazard warning lamps (→ page 110).
- ▶ Fit the towing eye (→ page 252).
- ▶ Secure the towing device.
- ▶ Switch on the vehicle.

- ▶ Deactivate automatic locking (→ page 56).
- ▶ Deactivate Active Brake Assist (→ page 159).
- ▶ Shift the transmission to neutral.
- ▶ Release the parking brake (→ page 153).

### Vehicles with automatic transmission

- ▶ Switch on the hazard warning lamps (→ page 110).
- ▶ Fit the towing eye (→ page 252).
- ▶ Secure the towing device.
- ▶ Switch on the vehicle.
- ▶ Deactivate automatic locking (→ page 56).
- ▶ Do not activate the HOLD function.
- ▶ Deactivate Active Brake Assist (→ page 159).
- ▶ Deactivate Active Distance Assist DISTRONIC (→ page 164).
- ▶ Shift the transmission to position **N** (→ page 144).
- ▶ Release the parking brake (→ page 153).

## Recovering a vehicle that is stuck

**!** **NOTE** Damage due to pulling force being too high

Pulling away abruptly can damage the vehicles if the tractive forces are too high.

- ▶ Pull away as straight, slowly and smoothly as possible.

If the drive wheels have become trapped on loose or muddy ground, recover the vehicle with the utmost care. This particularly applies if the vehicle is carrying a load.

- ▶ Observe the notes on permissible towing methods (→ page 248).
- ▶ Never attempt to recover a vehicle that is stuck when a trailer is attached.
- ▶ If possible, pull the vehicle out backwards using the tracks it made before it became stuck.

## Towing the vehicle with the axle raised

**!** **WARNING** Risk of accident due to towing when the vehicle is switched on

When the vehicle is being towed away and is switched on with the front axle raised, ASR can brake the rear axle wheels in an erratic manner.

The vehicle can lose directional stability.

- ▶ Switch off the vehicle before towing it with the front axle raised.

**!** **NOTE** Damage to the transmission due to towing with an axle raised on vehicles with 4MATIC

The transmission can be damaged by towing with the front or rear axle raised.

- ▶ Only tow vehicles equipped with 4MATIC with both axles on the ground, or load them onto another vehicle for transport.

## With the rear axle raised

- ▶ Observe the notes on permissible towing methods (→ page 248).
- ▶ Switch on the hazard warning lamps (→ page 110).
- ▶ Deactivate tow-away protection (→ page 70).

- ▶ Move the front wheels to the straight-ahead position.
- ▶ Fix the steering wheel in the centre position with a steering wheel lock.
- ▶ Release the parking brake (→ page 153).
- ▶ Turn the key to position **0** in the ignition lock and remove the key from the ignition lock.
- ▶ Take the key with you when leaving the vehicle.

Do not exceed a towing speed of 50 km/h.

## Loading the vehicle for transport

**!** **NOTE** Damage due to incorrect attachment

The vehicle may be damaged when lashing to chassis components.

- ▶ Only lash the vehicle at the wheels.

- ▶ Observe the notes on permissible towing methods (→ page 248).
- ▶ To load the vehicle onto a trailer or transporter, use the trailer tow hitch or the towing eye.

## Before loading the vehicle

- ▶ Switch on the vehicle.
- ▶ **Vehicles with manual transmission:** shift the transmission to neutral.
- ▶ **Vehicles with automatic transmission:** shift the transmission to position **N**.
- ▶ Release the parking brake (→ page 153).
- ▶ Load the vehicle onto the transporter.

**!** **NOTE** Damage to the drive train due to incorrect positioning of the vehicle

- ▶ Do not position the vehicle above the connection point of the transport vehicle.

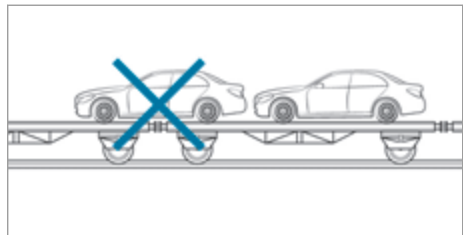

- ▶ Make sure that the front and rear axles come to rest on the same transportation vehicle.

### After loading the vehicle

- ▶ **Vehicles with manual transmission:** engage first or reverse gear.
- ▶ **Vehicles with automatic transmission:** shift the transmission to position **P**.
- ▶ Deactivate tow-away protection (→ page 70).
- ▶ Turn the key to position **0** in the ignition lock and remove it from the ignition lock.
- ▶ Use the parking brake to secure the vehicle against rolling away.
- ▶ Secure the vehicle by the wheels.

### Towing eye storage location

The towing eye is located in the vehicle tool kit (→ page 253).

### Fitting/removing the towing eye

#### Fitting and removing the front towing eye

**!** **NOTE** Damage to the vehicle due to incorrect use of the towing eye

When a towing eye is used to recover a vehicle, the vehicle may be damaged in the process.

- ▶ Only use the towing eye to tow away or tow start the vehicle.



Fixture for the front towing eye in the bumper

- ▶ Take the towing eye and screwdriver from the vehicle tool kit (→ page 253).

#### Fitting

- ▶ Press the arrow on cover **1** and remove cover **1** from the opening. You will see the fixture for the towing eye.
- ▶ Screw in the towing eye clockwise to the stop.
- ▶ Insert the screwdriver into the towing eye and tighten the towing eye.
- ▶ Stow the screwdriver in the vehicle tool kit.

### Removing

- ▶ Remove the screwdriver from the vehicle tool kit.
- ▶ Insert the screwdriver into the towing eye and turn the towing eye anti-clockwise.
- ▶ Unscrew and remove the towing eye.
- ▶ Insert cover **1** with the lug at the top and press it in at the bottom until it engages.
- ▶ Stow the towing eye and the screwdriver with the vehicle tool kit.

### Rear towing eye

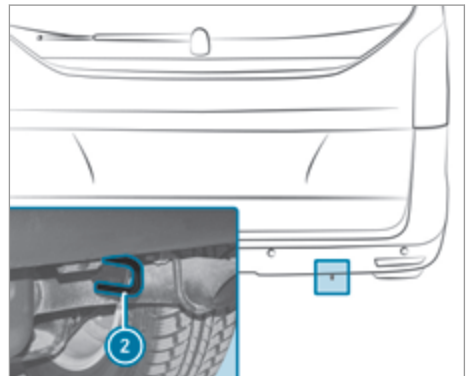

Rear towing eye under the bumper

- ▶ When towing away or tow-starting a vehicle, attach the towing device to rear towing eye **2**.
- ▶ If the vehicle is equipped with a trailer tow hitch, attach the towing device to the trailer tow hitch (→ page 282).
- ▶ Observe the notes on permissible towing methods (→ page 248).

### Tow-starting the vehicle (vehicle emergency start)

#### Vehicles with automatic transmission

**!** **NOTE** Damage to the automatic transmission due to tow-starting

The automatic transmission may be damaged in the process of tow-starting vehicles with automatic transmission.

- ▶ Vehicles with automatic transmission must not be tow-started.

- ▶ Observe the notes and information on starting assistance (→ page 243).

### Vehicles with manual transmission

- ▶ Observe the notes on permissible towing methods (→ page 248).

Before tow-starting, ensure the following:

- make sure that the battery is connected and charged. The vehicle cannot be switched on otherwise and there will be no steering and braking assistance.
- use a towing bar and attach it to the front towing eye (→ page 252) only.
- if the vehicle does not start after a few seconds, try a jump-starting procedure using the battery of another vehicle (→ page 243).

### Tow-starting procedure

- ▶ Switch on the hazard warning lamps (→ page 110).
- ▶ If necessary, allow the engine and the exhaust system to cool down.
- ▶ Switch on the vehicle.
- ▶ Shift to 2nd or 3rd gear.
- ▶ Release the parking brake.
- ▶ Keep the clutch pedal fully depressed when tow-starting the vehicle.
- ▶ Release the clutch pedal slowly.
- ▶ Immediately shift to neutral if the vehicle starts.
- ▶ Stop in accordance with the traffic conditions.
- ▶ Use the parking brake to secure the vehicle against rolling away.
- ▶ Remove the towing device.
- ▶ Remove the towing eye.
- ▶ Switch off the hazard warning lamps (→ page 110).

## Electrical fuses

### Notes on electrical fuses

**⚠ WARNING** Risk of accident and injury due to overloaded lines

If you manipulate or bridge a faulty fuse or if you replace it with a fuse with a higher amperage, the electric line could be overloaded.

This could result in a fire.

- ▶ Always replace faulty fuses with specified new fuses containing the correct amperage.

If the new fuse which has been inserted also blows, have the cause traced and rectified at a qualified specialist workshop.

The fuse allocation chart and the information on the fuses can be found in the "Fuse allocation chart" Supplement.

## Vehicle tool kit

### Information on the vehicle tool kit

The vehicle tool kit is in the rear stowage compartment.

Apart from some country-specific variants, vehicles without a spare wheel are not equipped with a tyre-changing tool.

If your vehicle is equipped with a tyre-change tool kit, you can find it in the vehicle tool kit in the rear stowage compartment.

Some tools for changing a wheel are specific to the vehicle. For more information on which tyre-change tool kits are required and approved for performing a wheel change on your vehicle, consult a qualified specialist workshop.

Required tyre-change tool kits may include the following, for example:

- Jack
- Wheel spanner
- Ratchet ring spanner

- ⓘ The jack has a maximum weight of 7.5 kg depending on the vehicle's equipment. You will find the maximum load capacity of the jack stated on the adhesive label attached to the jack. The jack is maintenance-free. If there is a malfunction, please contact a qualified specialist workshop.

## Stowage compartment in the rear

### Opening the stowage compartment

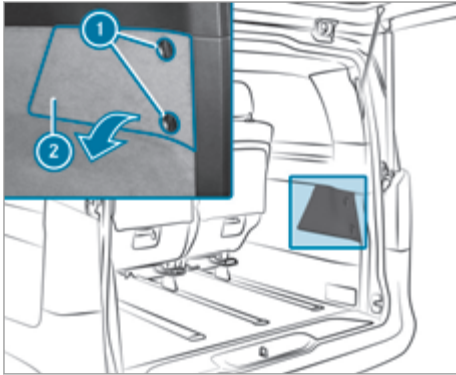

Stowage compartment in the rear on the right-hand side of the vehicle

- ▶ If necessary, fold up the rear seat.
- ▶ Turn top rotary catch ① clockwise and bottom rotary catch ① anti-clockwise.
- ▶ Remove cover ②.

### Removing the vehicle tool kit and jack from the tool holder

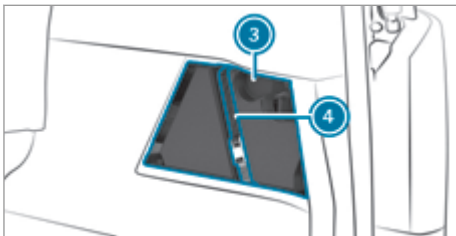

Stowage compartment with tool holder

- ▶ Remove clamping strap ④.
- ▶ Lift off tool holder cover ③.
- ▶ Carefully pull the vehicle tool kit and jack upwards out of the stowage compartment. Lift the jack slightly before removing it and turn it to a diagonal position in the stowage compartment.

### Stowing the vehicle tool kit and the jack

- ▶ Before stowing, wind the jack to the fully closed position and place it so that the hand-wheel is facing forwards and the plate is facing inwards.

- ▶ Place the jack and vehicle tool kit into the tool holder.
- ▶ Replace cover ③ of the tool holder.
- ▶ Tighten clamping strap ④.

### Closing the stowage compartment

- ▶ Put on cover ②.
- ▶ Turn top rotary catch ① anti-clockwise and bottom rotary catch ① clockwise.
- ▶ Fold down the rear seat.

### Information on noise or unusual driving characteristics

While driving, pay attention to vibrations, noises and unusual driving characteristics, e.g. pulling to one side. This may indicate damage to the wheels or tyres. If you suspect that a tyre is defective, reduce your speed. Stop the vehicle as soon as possible to check if wheels and tyres have been damaged or are no longer functioning properly. Hidden tyre damage could also be causing the unusual driving characteristics. If no signs of damage can be detected, have the tyres and wheels checked at a qualified specialist workshop.

### Notes on regularly inspecting wheels and tyres

**⚠ WARNING** Risk of injury due to damaged tyres

Damaged tyres can cause tyre pressure loss.

- ▶ Check the tyres regularly for signs of damage and replace any damaged tyres immediately.

Check the wheels and tyres of your vehicle for damage regularly, i.e. at least every two weeks, as well as after driving off-road or on rough roads. Damaged wheels can lead to a loss of tyre pressure.

Look out for the following types of damage, for example:

- cuts in the tyres
- punctures in the tyres
- tears in the tyres
- bulges on tyres
- deformation or severe corrosion on wheels

**⚠ WARNING** Risk of aquaplaning due to insufficient tyre tread

Insufficient tyre tread will result in reduced tyre grip.

The risk of aquaplaning is increased on wet roads, especially when the speed of the vehicle is not adapted to suit the conditions.

- ▶ Thus, you should regularly check the tread depth and the condition of the tread across the entire width of all tyres.

Minimum tread depth for:

- Summer tyres: 3 mm
- M+S tyres: 4 mm

- ▶ For safety reasons, replace the tyres before the legally-prescribed limit for the minimum tread depth is reached.

Conduct the following checks regularly on all wheels, at least once a month or as required, e.g. before a long journey or when driving off-road:

- check the tyre pressure (→ page 256)
- check the valve caps

Valves must be protected from moisture and dirt with valve caps specifically approved by Mercedes-Benz for your vehicle.

- visually inspect the tread depth and the tyre tread across the whole tyre width

The minimum tread depth for summer tyres is 3 mm and for winter tyres 4 mm.

### Information on driving with summer tyres

At temperatures below 10 °C summer tyres lose elasticity and therefore traction and braking power. Change the tyres on your vehicle to M+S tyres. Using summer tyres at very cold temperatures could cause tears to form, thereby damaging the tyres permanently. Mercedes-Benz cannot accept responsibility for this type of damage.

Once you have fitted the summer tyres:

- Check the tyre pressures (→ page 256)
- Restart the tyre pressure monitor (→ page 261)

### Information on M+S tyres

At temperatures below 10 °C, use winter tyres or all-season tyres that are marked with M+S.

Only winter tyres bearing the  snowflake symbol in addition to the M+S marking provide the best possible grip in wintry road conditions.

Only these tyres allow driving safety systems such as ABS and ESP® to also function optimally in winter. These tyres have been developed specifically for driving in snow.

Use M+S tyres of the same make and tread on all wheels to maintain safe handling characteristics.

Observe the maximum permissible speed specified for the M+S tyres you have fitted.

If you fit M+S tyres that have a lower maximum permissible speed than the maximum design speed of the vehicle, affix an appropriate warning sign in the driver's field of vision. You can obtain this at a qualified specialist workshop.

Once you have fitted the winter tyres M+S, take the following measures:

- check the tyre pressure (→ page 256)
- restart the tyre pressure monitoring system (→ page 261)

### Notes on snow chains

#### **⚠ WARNING** Risk of accident due to incorrectly fitted snow chains

If you have fitted snow chains to the front wheels, they may drag against the vehicle body or chassis components.

- ▶ Never fit snow chains to the front wheels.
- ▶ Only fit snow chains on the rear wheels in pairs.

For safety reasons, Mercedes-Benz recommends that you only use snow chains that have been checked and approved. You can find further information on snow chains recommended for Mercedes-Benz in the wheel and tyre overview at <https://www.mercedes-benz.de>.

#### **⚠ WARNING** Risk of accident due to snow chains breaking

If you drive too fast with snow chains, they can break, injure other persons, and damage the vehicle.

- ▶ Observe the maximum permissible speed for operation with snow chains.

#### **!** NOTE Damage to the wheel trim from fitted snow chains

If snow chains are fitted to steel wheels, the wheel trims can be damaged.

- ▶ Remove the wheel trims of steel wheels before fitting snow chains.

Observe the following notes when using snow chains:

- Snow chains are only permissible for certain wheel/tyre combinations. You can obtain infor-

mation on them at a qualified specialist workshop.

- For safety reasons, only use snow chains that have been specifically approved for your vehicle by Mercedes-Benz, or snow chains with the same quality standard.
  - The snow chains must be retightened after driving approximately 1 km. This is the only way to ensure the snow chains are optimally seated with clearance to adjacent components.
  - Use snow chains only when the road surface is completely snow-covered. Remove the snow chains as soon as possible when you come to a road that is not snow-covered.
  - Local regulations may restrict the use of snow chains. Observe the applicable regulations before fitting snow chains.
  - If snow chains are fitted, the maximum permissible speed is 50 km/h.
- i** You can deactivate ESP® to pull away (→ page 156). This allows the wheels to spin, achieving an increased driving force.

### Tyre pressure

#### Notes on tyre pressure

Driving with tyre pressure that is too high or too low can:

- Shorten the service life of the tyres
- Cause increased tyre damage
- Adversely affect handling characteristics and thus driving safety, for example, due to aquaplaning

#### **⚠ WARNING** Risk of accident due to repeated pressure drop in the tyres

The wheels, valves or tyres could be damaged. Too low a tyre pressure can lead to the tyres bursting.

- ▶ Examine the tyres for foreign objects.
- ▶ Check whether the tyre has a puncture or the valve has a leak.
- ▶ If you are unable to rectify the damage, contact a qualified specialist workshop.

Information on the recommended tyre pressure for the vehicle's factory-fitted tyres can be found on

the tyre pressure table in the fuel filler flap and in the tyre pressure tables (→ page 257).

Use a suitable pressure gauge to check the tyre pressure. The outer appearance of a tyre does not permit any reliable conclusion about the tyre pressure.

- ① The difference in pressure of the tyres of an axle may not be higher than 10 kPa (0.1 bar/ 1.5 psi).

#### Vehicles with a tyre pressure monitoring system:

you can also check the tyre pressure using the on-board computer.

Only correct tyre pressures when the tyres are cold. The tyres are cold if the following conditions have been met:

- The vehicle has been parked with the tyres out of direct sunlight for at least three hours.
- The vehicle has travelled less than 1.6 km.

#### Notes on trailer operation

The applicable tyre pressure for the tyres of the rear axle is always the recommended tyre pressure for a full load.

### Overview of the tyre pressure table

PRESSURE		COLD TYRES			
Warm tires up to + 30 km/h + 4 psi					
		MPa	PSI	MPa	PSI
195/65 R 16 C 104T / 100T					
205/65 R 16 C 103H/1					
245/45 R 19 XL <sup>1</sup> 102Y					
<sup>1</sup> XL = extra large - R = Reinforced					
100 kPa = 1 bar					

The tyre pressure table shows the recommended tyre pressure for all tyres approved at the factory for this vehicle. The recommended tyre pressures apply for cold tyres under various operating conditions, i.e. loading and/or speed of the vehicle.

If one or more tyre sizes precede a tyre pressure, the following tyre pressure information is only valid for those tyre sizes and their respective load condition.

If the preceding tyre sizes are supplemented by the symbol, the tyre pressure information following shows alternative tyre pressures. Fuel consumption may then increase slightly.

The load conditions "partially laden" and "fully laden" are defined in the table for different numbers of passengers and amounts of luggage. The actual number of seats may differ.

The tyre pressure values given for partly laden vehicles are minimum values which offer you good ride comfort. They are not for trailer operation.

You can also use the tyre pressure values for a fully laden vehicle. These are always allowed and permissible. However, in a partially laden vehicle, the ride is not as comfortable and fuel consumption is only minimally reduced. In addition, wear is greater in the middle of the tyre tread.

Set the correct tyre pressure before loading the vehicle. Once the vehicle is laden, check the tyre pressures and correct them if necessary.

#### Vehicles with a gross vehicle weight of 2,800 kg

The tyre pressure values apply to the following vehicles:

- with a permissible gross vehicle weight of 2,800 kg
- the tyres referred to under "Wheel and tyre combinations" (→ page 266)

Tyre pressure for the spare wheel is 350 kPa (3.5 bar/51 psi).

#### Vehicles with a permissible axle load of 1,490 kg on the front and rear axles

Tyres/disk wheel	Partially laden vehicle		Fully laden vehicle	
	Front axle	Rear axle	Front axle	Rear axle
195/65 R 16 C	340 kPa (3.4 bar/49 psi)	340 kPa (3.4 bar/49 psi)	360 kPa (3.6 bar/52 psi)	360 kPa (3.6 bar/52 psi)
205/65 R 16 C	310 kPa (3.1 bar/45 psi)	310 kPa (3.1 bar/45 psi)	340 kPa (3.4 bar/49 psi)	340 kPa (3.4 bar/49 psi)

Tyres/disk wheel	Partially laden vehicle		Fully laden vehicle	
	Front axle	Rear axle	Front axle	Rear axle
225/60 R 16 C	300 kPa (3.0 bar/44 psi)	300 kPa (3.0 bar/44 psi)	320 kPa (3.2 bar/46 psi)	320 kPa (3.2 bar/46 psi)
225/55 R 17 C	310 kPa (3.1 bar/45 psi)	310 kPa (3.1 bar/45 psi)	330 kPa (3.3 bar/48 psi)	330 kPa (3.3 bar/48 psi)
225/55 R 17 XL	270 kPa (2.7 bar/39 psi)	260 kPa (2.6 bar/38 psi)	290 kPa (2.9 bar/42 psi)	300 kPa (3.0 bar/44 psi)
235/55 R 17 XL 103W/V	260 kPa (2.6 bar/38 psi)	250 kPa (2.5 bar/36 psi)	270 kPa (2.7 bar/39 psi)	280 kPa (2.8 bar/41 psi)
245/45 R 18 XL 100W	270 kPa (2.7 bar/39 psi)	260 kPa (2.6 bar/38 psi)	290 kPa (2.9 bar/42 psi)	310 kPa (3.1 bar/45 psi)
245/45 R 18 XL 100V	280 kPa (2.8 bar/41 psi)	270 kPa (2.7 bar/39 psi)	300 kPa (3.0 bar/44 psi)	310 kPa (3.1 bar/45 psi)
245/45 R 19 XL 102Y	230 kPa (2.3 bar/33 psi)	230 kPa (2.3 bar/33 psi)	250 kPa (2.5 bar/36 psi)	260 kPa (2.6 bar/38 psi)
245/45 R 19 XL 102W/V	260 kPa (2.6 bar/38 psi)	260 kPa (2.6 bar/38 psi)	280 kPa (2.8 bar/41 psi)	290 kPa (2.9 bar/42 psi)

**Vehicles with a gross vehicle weight of 3,050 kg or 3,100 kg without all-wheel drive 4MATIC**

Tyre pressure for the spare wheel is 350 kPa (3.5 bar/51 psi).

The following tyre pressure values apply to the following vehicles:

- with a gross vehicle weight of 3,050 kg or 3,100 kg
- the tyres referred to under "Wheel and tyre combinations" (→ page 266)

**Vehicles with a permissible axle load of 1,550 kg on the rear axle**

Tyres/disk wheel	Partially laden vehicle <sup>1</sup>		Fully laden vehicle	
	Front axle	Rear axle	Front axle	Rear axle
205/65 R 16 C	310 kPa (3.1 bar/45 psi)	310 kPa (3.1 bar/45 psi)	360 kPa (3.6 bar/52 psi)	360 kPa (3.6 bar/52 psi)
225/60 R 16 C	300 kPa (3.0 bar/44 psi)	300 kPa (3.0 bar/44 psi)	340 kPa (3.4 bar/49 psi)	340 kPa (3.4 bar/49 psi)
225/55 R 17 XL	270 kPa (2.7 bar/39 psi)	260 kPa (2.6 bar/38 psi)	300 kPa (3.0 bar/44 psi)	310 kPa (3.1 bar/45 psi)
235/55 R 17 XL 103W/V	260 kPa (2.6 bar/38 psi)	250 kPa (2.5 bar/36 psi)	280 kPa (2.8 bar/41 psi)	290 kPa (2.9 bar/42 psi)

<sup>1</sup> The tyre pressures for the partially laden vehicle are not valid for the Marco Polo with integrated kitchen.

Tyres/disk wheel	Partially laden vehicle <sup>1</sup>		Fully laden vehicle	
	Front axle	Rear axle	Front axle	Rear axle
245/45 R 18 XL 100W	270 kPa (2.7 bar/39 psi)	260 kPa (2.6 bar/38 psi)	310 kPa (3.1 bar/45 psi)	330 kPa (3.3 bar/48 psi)
245/45 R 18 XL 100V	280 kPa (2.8 bar/41 psi)	270 kPa (2.7 bar/39 psi)	320 kPa (3.2 bar/46 psi)	330 kPa (3.3 bar/48 psi)
245/45 R 19 XL 102Y	230 kPa (2.3 bar/33 psi)	230 kPa (2.3 bar/33 psi)	260 kPa (2.6 bar/38 psi)	270 kPa (2.7 bar/39 psi)
245/45 R 19 XL 102W/V	260 kPa (2.6 bar/38 psi)	260 kPa (2.6 bar/38 psi)	290 kPa (2.9 bar/42 psi)	300 kPa (3.0 bar/44 psi)

### Vehicles with a gross vehicle weight of 3,050 kg or 3,100 kg and 4MATIC

The following tyre pressure values apply to the following vehicles:

- with a gross vehicle weight of 3,050 kg or 3,100 kg
- with 4MATIC
- the tyres referred to under "Wheel and tyre combinations" (→ page 266)

### Vehicles with a permissible axle load of 1,550 kg on the rear axle

Tyres/disk wheel	Partially laden vehicle <sup>1</sup>		Fully laden vehicle	
	Front axle	Rear axle	Front axle	Rear axle
225/55 R 17 C	320 kPa (3.2 bar/46 psi)	310 kPa (3.1 bar/45 psi)	350 kPa (3.5 bar/51 psi)	350 kPa (3.5 bar/51 psi)
225/55 R 17 XL	280 kPa (2.8 bar/41 psi)	260 kPa (2.6 bar/38 psi)	310 kPa (3.1 bar/45 psi)	310 kPa (3.1 bar/45 psi)
235/55 R 17 XL 103W/V	270 kPa (2.7 bar/39 psi)	250 kPa (2.5 bar/36 psi)	290 kPa (2.9 bar/42 psi)	290 kPa (2.9 bar/42 psi)
245/45 R 18 XL 100V	290 kPa (2.9 bar/42 psi)	270 kPa (2.7 bar/39 psi)	330 kPa (3.3 bar/48 psi)	330 kPa (3.3 bar/48 psi)
245/45 R 18 XL 100W	280 kPa (2.8 bar/41 psi)	260 kPa (2.6 bar/38 psi)	320 kPa (3.2 bar/46 psi)	330 kPa (3.3 bar/48 psi)
245/45 R 19 XL 102Y	230 kPa (2.3 bar/33 psi)	230 kPa (2.3 bar/33 psi)	260 kPa (2.6 bar/38 psi)	270 kPa (2.7 bar/39 psi)
245/45 R 19 XL 102W/V	260 kPa (2.6 bar/38 psi)	260 kPa (2.6 bar/38 psi)	290 kPa (2.9 bar/42 psi)	300 kPa (3.0 bar/44 psi)

<sup>1</sup> The tyre pressures for the partially laden vehicle are not valid for the Marco Polo with integrated kitchen.

### Vehicles with a gross vehicle weight of 3,200 kg and all-wheel drive 4MATIC

The following tyre pressure values apply to the following vehicles:

- with a gross vehicle weight of 3,200 kg
- with 4MATIC
- the tyres referred to under "Wheel and tyre combinations" (→ page 266)

Tyre pressure for the spare wheel is 350 kPa (3.5 bar/51 psi).

### Vehicles with a permissible axle load of 1,650 kg on the rear axle

Tyres/disk wheel	Partially laden vehicle <sup>1</sup>		Fully laden vehicle	
	Front axle	Rear axle	Front axle	Rear axle
225/55 R 17 C	320 kPa (3.2 bar/46 psi)	310 kPa (3.1 bar/45 psi)	350 kPa (3.5 bar/51 psi)	440 kPa (4.4 bar/64 psi)
235/55 R 17 XL 103W/V	270 kPa (2.7 bar/39 psi)	250 kPa (2.5 bar/36 psi)	280 kPa (2.9 bar/41 psi)	310 kPa (3.1 bar/45 psi)
245/45 R 19 XL 102Y	230 kPa (2.4 bar/33 psi)	230 kPa (2.3 bar/33 psi)	260 kPa (2.7 bar/38 psi)	280 kPa (2.8 bar/41 psi)
245/45 R 19 XL 102W/V	270 kPa (2.7 bar/39 psi)	270 kPa (2.7 bar/39 psi)	290 kPa (2.9 bar/42 psi)	310 kPa (3.1 bar/45 psi)

### Tyre pressure monitoring system

#### Function of the tyre pressure monitoring system



The system checks the tyre pressure and the tyre temperature of the tyres fitted to the vehicle by means of a tyre pressure sensor.

New tyre pressure sensors, e.g. in winter tyres, are automatically taught-in during the first journey they are used.

It is the driver's responsibility to set the tyre pressure to the recommended cold tyre pressure suitable for the operating situation (→ page 256).

Note that the correct tyre pressure for the current operating situation must first be taught-in to the tyre pressure monitoring system. If a substantial loss of pressure occurs, the warning threshold for the warning message is aligned to the taught-in reference values. Restart the tyre pressure monitor after adjusting to the cold tyre pressure (→ page 261). The current pressures are saved as new reference values. This will ensure that a warning message will only appear if the tyre pressure drops significantly.

The  warning lamp in the instrument cluster displays a detected pressure loss or a malfunction as follows:



- if the  warning lamp is lit continuously, the tyre pressure on one or more tyres is significantly too low. The tyre pressure monitor is not malfunctioning.
- if the  warning lamp flashes for around a minute and then remains lit constantly, the tyre pressure monitor is malfunctioning.
- a message also appears in the instrument cluster.

#### System limits

The system may be impaired or may not function in the following situations:

- the tyre pressure has been set incorrectly.
- there is a sudden pressure loss caused, for example, by a foreign object penetrating the tyre.
- there is a malfunction caused by another radio signal source.

<sup>1</sup> The tyre pressures for the partially laden vehicle are not valid for the Marco Polo with integrated kitchen.

If the tyre pressure monitor is malfunctioning, it may take more than ten minutes for the  tyre pressure warning lamp to inform you of the malfunction. When the fault has been rectified, the  warning lamp goes out after you have driven for a few minutes.

The tyre pressure values indicated by the on-board computer may differ from those measured at a filling station using a pressure gauge.







The tyre pressures shown by the on-board computer refer to those measured at sea level. At high altitudes, the tyre pressure values indicated by a pressure gauge are higher than those shown by the on-board computer. In this case, do not reduce the tyre pressures.

### Checking the tyre pressure electronically

#### Requirements:

- The vehicle is switched on.













- ▶ Press the  button to call up the list of menus.
- ▶ Press the  or  button to select **Service**.
- ▶ Press the  button.
- ▶ Press the  or  button to select **Tyre pressure**.
- ▶ Press the  button.  
The display shows the current tyre pressure of each wheel.

If the vehicle was parked for longer than 20 minutes, the **Tyre pressures will be displayed after a few minutes of driving** message appears in the display.

- ① Also be sure to observe the notes on tyre pressure (→ page 256).

### Restarting the tyre pressure monitor

#### Requirements:

- The vehicle is switched on.
  - The recommended tyre pressure is correctly set for the respective operating condition on each of the four wheels (→ page 257).
- ▶ Press the  button to call up the list of menus.
  - ▶ Use the  or  button to select **Service**.
  - ▶ Press the  button.
  - ▶ Use the  or  button to select **Tyre pressure**.
  - ▶ Press the  button.  
The display shows the current tyre pressure of each wheel or the **Tyre pressures will be displayed after a few minutes of driving** message.
  - ▶ Press the  button.  
The **Use current pressures as new reference values** message is shown in the display.
  - ▶ **To confirm restart:** press the  button.  
After you have driven for a few minutes, the system checks whether the current tyre pressures are within the specified range. The new tyre pressures are then saved as reference values, monitored and displayed.
  - ▶ **To cancel restart:** press the  button.  
The tyre pressure values stored at the last restart will continue to be monitored.

### Changing a wheel

#### Notes on selecting, fitting and replacing tyres

You can ask for information regarding permitted wheel/tyre combinations at a qualified specialist workshop.

- ⚠ **WARNING** Risk of accident due to incorrect wheel and tyre dimensions

If wheels and tyres of the wrong size are fitted, the service brakes or components in the brake system and in the wheel suspension may be damaged.

- ▶ Always replace wheels and tyres with those that fulfil the specifications of the original part.

For wheels, pay attention to the following:

- Designation
- Type

For tyres, pay attention to the following:

- Designation
- Manufacturer
- Type

**⚠ WARNING** Risk of injury through exceeding the specified tyre load-bearing capacity or the permissible speed rating

Exceeding the load-bearing capacity of the tyres can lead to tyre damage and could cause the tyres to explode.

- ▶ Therefore, only use tyre types and sizes approved for your vehicle model.
- ▶ Observe the tyre load-bearing capacity rating and speed rating required for your vehicle.

**! NOTE** Vehicle and tyre damage due to tyre types and sizes that have not been approved

For safety reasons, only use tyres, wheels and accessories which have been specially approved by Mercedes-Benz for your vehicle.

These tyres have been specially adapted for use with driving systems and driving safety systems, such as ABS or ESP®.

Otherwise, certain properties, such as handling characteristics, vehicle noise emissions and consumption could be adversely affected. Other wheel sizes may cause the tyres to come into contact with the vehicle body and axle components when under load. This may result in damage to the tyre or the vehicle.

- ▶ Only use tyres, wheels and accessories that have been checked and recommended by Mercedes-Benz.

**! NOTE** Driving safety put at risk by retreaded tyres

Retreaded tyres are not checked or recommended by Mercedes-Benz, as previous damage is not always detected during the retread process.

Driving safety cannot, therefore, be guaranteed.

- ▶ Do not use used tyres when their previous usage is unknown.

**! NOTE** Possible wheel and tyre damage when driving over obstacles

Large wheels have a smaller section width. As the section width decreases, the risk of wheels and tyres being damaged when driving over obstacles increases.

- ▶ Avoid obstacles or drive especially carefully.
- ▶ Reduce your speed when driving over kerbs, speed bumps, manhole covers and potholes.
- ▶ Avoid particularly high kerbs.

**! NOTE** Damage to electronic component parts through the use of tyre-fitting tools

**Vehicles with tyre pressure monitoring system:** there are electronic component parts in the wheel.

- ▶ Do not use any fitting tools near the valve.
- ▶ Only have tyres changed at a qualified specialist workshop.

Accessories that are not approved for your vehicle by Mercedes-Benz, or are not being used correctly, can impair operating safety.

Before purchasing and using non-approved accessories, visit a qualified specialist workshop and enquire about:

- suitability
- legal stipulations
- factory recommendations

Observe the following points when selecting, fitting and replacing tyres:

- Country-specific requirements for tyre approval that define a specific tyre type for your vehicle.

Furthermore, the use of certain tyre types in certain regions and areas of operation can be highly beneficial.

- Use only tyres and wheels of the same type, design (summer tyres, winter tyres, all-season tyres) and make.
- Only fit wheels of the same size and tread design on one axle (left and right).

It is only permissible to fit a different wheel size to this in the event of a flat tyre in order to drive to the specialist workshop.

- Only fit tyres of the correct size onto the wheels.
- Do not make any modifications to the brake system, the wheels or the tyres.

The use of shims or brake dust shields is not permitted and results in the invalidation of the vehicle's general operating permit.

- **Vehicles with a tyre pressure monitoring system:** all fitted wheels must be equipped with functioning sensors for the tyre pressure monitoring system.
- At temperatures below 10 °C use winter tyres or all-season tyres with the M+S marking on all wheels.

Winter tyres bearing the  snowflake symbol in addition to the M+S marking provide the best possible grip in wintry road conditions.

- For M+S tyres, only use tyres with the same tread.
- Observe the maximum permissible speed for the M+S tyres fitted.

If this is below the vehicle's maximum permissible speed, this must be indicated in an appropriate label in the driver's field of vision.

- Run in new tyres at moderate speeds for the first 100 km.
- Replace the tyres after six years at the latest, regardless of wear.

For more information on wheels and tyres, contact a qualified specialist workshop.

Also observe the following further related subjects:

- Notes on tyre pressure (→ page 256)
- Tyre pressure table (→ page 257)
- Notes on the emergency spare wheel (→ page 269)

### Notes on changing wheels

**⚠ WARNING** Risk of injury through different wheel sizes

Interchanging the front and rear wheels can severely impair the driving characteristics.

The disk brakes or wheel suspension components may also be damaged.

▶ Only interchange the front and rear wheels if the wheels and tyres have the same dimensions.

Interchanging the front and rear wheels if the wheels or tyres have different dimensions can render the general operating permit invalid.

On vehicles with the same front and rear wheel size, you can interchange the wheels every 5,000 to 10,000 km depending on the wear. Ensure the direction of rotation is maintained for the wheels.

It is imperative to observe the instructions and safety notes on "Changing a wheel" when doing so.

### Size categories of wheels

The determined vehicle speed is displayed in the instrument cluster and is important for controlling the driving safety systems and driving systems. The display accuracy of the speedometer and the odometer is legally prescribed. Determining the speed is dependent on the tyre size or the rolling circumference of the tyres. The rim diameter is always specified in inches.

For this reason, the vehicle control units can be coded for the following wheel size categories:

#### Wheel size categories

Wheel size category 1	Wheel size category 2
195/65 R 16 C	225/55 R 17 XL
205/65 R 16 C	235/55 R 17 XL
225/60 R 16 C	245/55 R 17 XL
225/55 R 17 C	245/45 R 18 XL
225/55 R 17 XL	245/50 R 18 XL
245/45 R 18 XL	245/45 R 19 XL

**i** Mercedes-Benz recommends that you stay within a wheel size category when changing a tyre. In this way, you avoid recoding the control units.

Due to the legally prescribed accuracy of the speedometer and odometer displays, the following tyres are not permitted for taxis and hire cars:

- Wheel size category 1
  - 195/65 R16C
- Wheel size category 2
  - 225/55 R17XL
  - 245/45 R18XL

If the wheel size category changes, you must have your vehicle's control units recoded at a qualified specialist workshop.

### Information on the direction of tyre rotation

Tyres with a specified direction of rotation have additional benefits, e.g. if there is a risk of aquaplaning. You will only gain these benefits if the correct direction of rotation is observed.

An arrow on the sidewall of the tyre indicates its correct direction of rotation.

You may also fit a spare wheel against the direction of rotation. Observe the time restriction on use as well as the speed restriction specified on the spare wheel.

### Information on storing wheels

Observe the following when storing wheels:

- Wheels that have been removed should be stored in a cool, dry and, if possible, dark place.
- Protect the tyres from oil, grease and fuel.

### Preparing the vehicle for a wheel change

#### Requirements:

- The tyre-change tool kit is available.
  - The vehicle is not on a slope.
  - The vehicle is on solid, non-slippery and level ground.
- ▶ Apply the parking brake.
  - ▶ Move the front wheels to the straight-ahead position.
  - ▶ **Vehicles with manual transmission:** engage first or reverse gear **[R]**.
  - ▶ **Vehicles with automatic transmission:** shift the transmission to position **[P]**.
  - ▶ Switch off the vehicle.
  - ▶ Make sure that the vehicle cannot be switched on.
  - ▶ **On level terrain:** place chocks or other suitable objects under the front and rear of the wheel that is diagonally opposite the wheel to be changed.
  - ▶ **On slight inclines:** place chocks or other suitable objects under the wheels on the front and rear axles opposite the wheel to be changed.

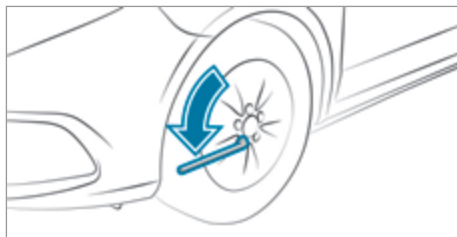

- ▶ If included in the vehicle equipment, take the tyre-change tool kit out of the vehicle tool kit (→ page 254).
- ▶ If included in the vehicle equipment, remove the spare wheel from the spare wheel holder (→ page 270).
- ▶ If necessary, remove the wheel trim.
- ▶ Using the wheel wrench, loosen the wheel bolts on the wheel you wish to change by about one full turn. Do not unscrew the wheel bolts.
- ▶ Raise the vehicle (→ page 264).

### Raising the vehicle when changing a wheel

**⚠ WARNING** Risk of injury from incorrect positioning of the jack

If you do not position the jack correctly at the appropriate jacking point of the vehicle, the jack could tip with the vehicle raised.

- ▶ Only position the jack at the appropriate jacking point of the vehicle. The base of the jack must be positioned vertically under the jacking point of the vehicle.

**⚠ WARNING** Risk of injury from vehicle tipping

On slopes, the jack could tip with the vehicle raised.

- ▶ Never change a wheel on a slope.
- ▶ Consult a qualified specialist workshop.

**! NOTE** Vehicle damage from the jack

If you do not position the jack correctly at the appropriate jack support point of the vehicle, the jack could tip over with the vehicle raised.

- ▶ The jack is designed exclusively for jacking up the vehicle at the jack support points.

**Requirements:**

- There are no persons in the vehicle.
- The vehicle is prepared for changing a wheel (→ page 264).

**Important notes on using the jack:**

- Only use the vehicle-specific jack that has been tested and approved by Mercedes-Benz to raise the vehicle. If the jack is used incorrectly, it could tip over while the vehicle is raised.
- The jack is designed only to raise the vehicle for a short time while a wheel is being changed and is not suitable for carrying out maintenance work under the vehicle.
- Avoid changing a wheel on uphill and downhill slopes.
- The jack must be placed on a firm, flat and non-slip surface. If necessary, use a large, flat, load bearing and non-slip underlay.
- The base of the jack is positioned vertically under the jack support point.

**Safety instructions while the vehicle is raised:**

- Do not put your hands or feet under the vehicle.
- Do not lie underneath the vehicle.
- Do not start the vehicle and do not release the parking brake.
- Do not open or close any doors.

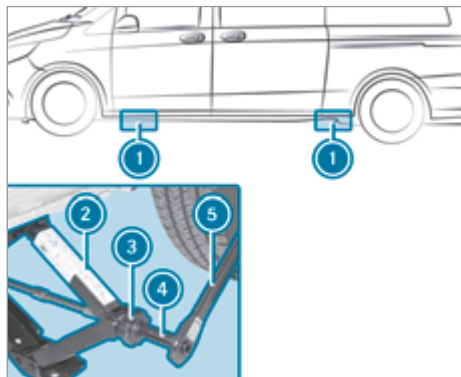

Jacking points ① (rubber stoppers) are located behind the front wheel arches and in front of the rear wheel arches.

- ▶ Place jack ② beneath corresponding jack support point ①.

- ▶ Turn handwheel ③ until the plate of jack ② sits securely on jack support point ①.
- ▶ Ensure that the base of jack ② is positioned vertically under jacking point ①.
- ▶ Assemble adapter ④ and ratchet ⑤ from the vehicle tool kit.
- ▶ Place adapter ④ and ratchet ⑤ on the hexagon nut of jack ② so that the lettering AUF/UP is visible.
- ▶ Turn ratchet wrench ⑤ in the AUF/UP direction until the tyre is raised a maximum of 3 cm off the ground. When doing so, jack ② may move to one of the side support surfaces.

**Removing a wheel****Requirements:**

- The vehicle is raised (→ page 264).

When changing a wheel, avoid applying any force to the brake discs since this could impair the level of comfort when braking.

**NOTE** Damage to threading from dirt on wheel bolts

- ▶ Do not place wheel bolts in sand or on a dirty surface.

- ▶ Remove the wheel bolts.
- ▶ Remove the wheel.

**Fitting a new wheel****Requirements**

- The wheel is removed (→ page 265).

**WARNING** Risk of accident from losing a wheel

Oiled or greased wheel bolts can cause the wheel bolts to come loose, as too can damaged wheel bolts or wheel hub threads.

- ▶ Never oil or grease the threads.
- ▶ In the event of damage to the threads, contact a qualified specialist workshop immediately.
- ▶ Have the damaged wheel bolts or damaged hub threads replaced.
- ▶ Do not continue driving.

**⚠ WARNING** Risk of injury from tightening wheel bolts and nuts

If you tighten the wheel bolts or wheel nuts when the vehicle is raised, the jack could tip.

- ▶ Only tighten wheel bolts or wheel nuts when the vehicle is on the ground.

- ▶ Observe the information on the choice of tyres (→ page 261).
- ▶ Observe the instructions and safety notes on changing a wheel (→ page 261).
- ▶ For safety reasons, only use wheel bolts or wheel nuts which have been approved by Mercedes-Benz and for the wheel in question.
- ▶ Clean the wheel and wheel hub contact surfaces.

### Lowering the vehicle after a wheel change

**⚠ WARNING** Risk of accident due to incorrect tightening torque

The wheels could come loose if the wheel bolts or wheel nuts are not tightened to the prescribed torque.

- ▶ Ensure that the wheel bolts or wheel nuts are tightened to the prescribed tightening torque.
- ▶ If you are not sure, do not move the vehicle. Contact a qualified specialist workshop and have the tightening torque checked immediately.

#### Requirements:

- The new wheel has been fitted (→ page 265).

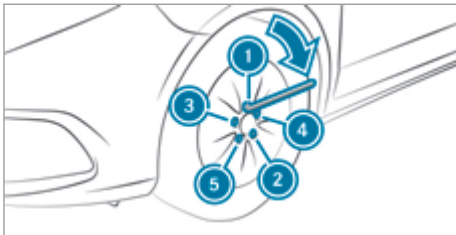

- ▶ Place the adapter and the ratchet on the hexagon head nut of the jack such that the lettering AB/DOWN is visible.
- ▶ **To lower the vehicle:** turn the ratchet of the jack anti-clockwise.

- ▶ **Steel wheels:** tighten the wheel bolts evenly in a crosswise pattern in the sequence indicated (1 to 5) and to a maximum of 200 Nm.

- ▶ **Light-alloy wheels:** tighten the wheel bolts evenly in a crosswise pattern in the sequence indicated (1 to 5) and to a maximum of 180 Nm.

- ▶ Check the tyre pressure of the newly fitted wheel and adjust it if necessary.

**Vehicles with the tyre pressure monitor system:** all fitted wheels must be equipped with functioning sensors.

- ▶ Retighten the wheel bolts to the specified tightening torque after the vehicle has been driven 50 km.

- ⓘ When using a wheel or spare wheel with a new or newly painted disk wheel, have the wheel bolts retightened again after approximately 1,000 to 5,000 km. Observe the specified tightening torque.

### Information on wheel and tyre combinations

#### General notes

Information on tyres, wheels and permissible combinations can be obtained at a qualified specialist workshop.

The smaller the cross-section of a tyre of a specific wheel size, the worse the driving comfort on poor road surfaces. Ride and damping comfort are reduced and the risk increases that when you drive over obstacles, damage to wheels and tyres may result.

If you change wheel size on your vehicle, check it is assigned to the correct wheel size category (→ page 263). If the assignment changes without recoding the control units in the vehicle, the speedometer will not display the speed accurately. Driving safety systems and driving systems may then be operationally impaired or may detect a malfunction and switch themselves off.

You will find a table with the recommended tyre pressures for various vehicle loads on the inside of the vehicle's fuel filler flap or under "Tyre pressure tables" (→ page 257).

Check tyre pressures regularly and only when the tyres are cold.

Observe the following notes:

- always fit the vehicle with tyres of the same size on a given axle (left/right)
- always fit the same type of wheels on your vehicle at a given time (summer tyres, winter tyres)

You can obtain information about tyres that have been specially designed and approved for your vehicle from a Mercedes-Benz Service Centre.

 Not all wheel/tyre combinations can be fitted at the factory in all countries.

## Tyres R16

Tyres	Steel or light-alloy wheels
195/65 R16 C 100/98T	6.5 J x 16 H2 ET 52
195/65 R16 C 104/102T (100T)	6.5 J x 16 H2 ET 52
205/65 R16 C 107/105T (103T)	6.5 J x 16 H2 ET 52
205/65 R16 C 107/105T (103H)	6.5 J x 16 H2 ET 52
205/65 R16 C 103/101H	6.5 J x 16 H2 ET 52
225/60 R16 C 105/103H	6.5 J x 16 H2 ET 52

195/65 R16 C 100/98T: only for vehicles with a gross vehicle weight up to 2,800 kg.

## R17

Tyres	Steel wheels
225/55 R17 C 109/107H (104H)	6.5 J x 17 H2 ET 50
225/55 R17 C 104/102H (106N)	6.5 J x 17 H2 ET 50
225/55 R17 C 109/107T (104T)	6.5 J x 17 H2 ET 50
225/55 R17 XL 101V	6.5 J x 17 H2 ET 50
225/55 R17 XL 101H	6.5 J x 17 H2 ET 50
235/55 R17 XL 103W/V	6.5 J x 17 H2 ET 50

## R17

Tyres	Light-alloy wheels
225/55 R17 C 109/107H (104H)	7 J x 17 H2 ET 51
225/55 R17 C 104/102H (106N)	7 J x 17 H2 ET 51
225/55 R17 C 109/107T (104T)	7 J x 17 H2 ET 51

Tyres	Light-alloy wheels
225/55 R17 XL 101V	7 J x 17 H2 ET 51
225/55 R17 XL 101H	7 J x 17 H2 ET 51
235/55 R17 XL 103W/V	7 J x 17 H2 ET 51

**R18**

Tyres	Light-alloy wheels
245/45 R18 XL 100W	7.5 J x 18 H2 ET 52
245/45 R18 XL 100V	7.5 J x 18 H2 ET 52

245/45 R18 XL 100W: only for vehicles with a permissible gross weight up to 3,100 kg and a permissible axle load of 1,550 kg on the rear axle. Not for vehicles with a gross vehicle weight up to 3,200 kg.

245/45 R18 XL 100V: only for vehicles with a permissible gross weight up to 3,100 kg and a permissible axle load of 1,550 kg on the rear axle. Not for vehicles with a gross vehicle weight up to 3,200 kg.

**R19**

Tyres	Light-alloy wheels
245/45 R19 XL 102Y	8 J x 19 H2 ET 52

245/45 R19 XL 102Y: only for vehicles with a permissible gross weight up to 3,200 kg and a permissible axle load of 1,650 kg on the rear axle. Use of snow chains is not permitted. Observe the notes under "Snow chains".

The following additional wheel/tyre combinations apply to vehicles with 4MATIC.

**R17**

Tyres	Steel wheels
225/55 R17 C 109/107H (104H)	6.5 J x 17 H2 ET 50
225/55 R17 C 104/102H (106N)	6.5 J x 17 H2 ET 50
225/55 R17 C 109/107T (104T)	6.5 J x 17 H2 ET 50
225/55 R17 XL 101H/V12	6.5 J x 17 H2 ET 50
235/55 R17 XL 103W/V	6.5 J x 17 H2 ET 50

**R17**

Tyres	Light-alloy wheels
225/55 R17 C 109/107H (104H)	7 J x 17 H2 ET 51
225/55 R17 C 104/102H (106N)	7 J x 17 H2 ET 51

Tyres	Light-alloy wheels
225/55 R17 C 109/107T (104T)	7 J x 17 H2 ET 51
225/55 R17 XL 101H/V	7 J x 17 H2 ET 51
235/55 R17 XL 103W/V	7 J x 17 H2 ET 51

225/55 R17 XL 101H/V: only for vehicles with a permissible gross weight up to 3,100 kg and a permissible axle load of 1,550 kg on the rear axle.

## R18

Tyres	Light-alloy wheels
245/45 R18 XL 100W	7.5 J x 18 H2 ET 52
245/45 R18 XL 100V	7.5 J x 18 H2 ET 52

245/45 R18 XL 100W: only for vehicles with a permissible gross weight up to 3,100 kg and a permissible axle load of 1,550 kg on the rear axle. Not for vehicles with a gross vehicle weight up to 3,200 kg.

245/45 R18 XL 100V: only for vehicles with a permissible gross weight up to 3,100 kg and a permissible axle load of 1,550 kg on the rear axle. Not for vehicles with a gross vehicle weight up to 3,200 kg.

## R19

Tyres	Light-alloy wheels
245/45 R19 XL 102Y	8 J x 19 H2 ET 52

245/45 R19 XL 102Y: only for vehicles with a permissible gross weight up to 3,200 kg and a permissible axle load of 1,650 kg on the rear axle. Use of snow chains is not permitted. Observe the notes under "Snow chains".

### Spare wheel

#### Notes on the emergency spare wheel and spare wheel

**Emergency spare wheel:** wheel and/or tyre dimensions as well as the type of tyre are different from the wheel to be replaced.

 A label with the limit speed and tyre pressure can be found on the emergency spare wheel.

**Spare wheel:** wheel and tyre dimensions as well as the type of tyre correspond to the other fitted wheels.

A fitted emergency spare wheel or spare wheel changes the driving characteristics and bears risks.

#### **WARNING** Risk of accident due to incorrect wheel and tyre dimensions

Mounting an emergency spare wheel or spare wheel may severely impair the driving characteristics.

There is an increased risk of an accident.

To prevent hazardous situations:

- ▶ Check the tyre pressure of the spare wheel or emergency spare wheel once fitted and, if necessary, adjust.
- ▶ The emergency spare wheel may only be used temporarily and must be replaced with a standard wheel as soon as possible.
- ▶ Never fit more than one emergency spare wheel.
- ▶ Adapt your driving style and drive carefully in emergency spare wheel mode.
- ▶ Do not switch off ESP®.

- ▶ Do not use snow chains on the emergency spare wheel.
- ▶ Replace the emergency spare wheel after six years at the latest, regardless of wear.

- When using an emergency spare wheel or spare wheel (different from the wheel to be replaced), you must not exceed a permissible top speed of 80 km/h.
- Have the emergency spare wheel or spare wheel replaced by a qualified specialist workshop (→ page 261).
- The tyre pressure of the emergency spare wheel or spare wheel must be checked before starting a journey and, if necessary, adjusted (→ page 257).

The following should be checked regularly, particularly prior to long journeys:

- that the emergency spare wheel or spare wheel are firmly secured
- the tyre pressure of the emergency spare wheel or spare wheel (adjust the tyre pressure if necessary) (→ page 257)
- the fastenings of the emergency spare wheel holder or spare wheel holder

The spare wheel is located in a spare wheel holder under the rear of the vehicle.

Replace the tyres after six years at the latest, regardless of wear. This also applies to the spare wheel.

- ⓘ If you have fitted a spare wheel, the tyre pressure monitor will not function for this wheel. The spare wheel is not equipped with a sensor for monitoring tyre pressure.

### Fitting and removing the spare wheel

#### Removing the spare wheel under the rear of the vehicle

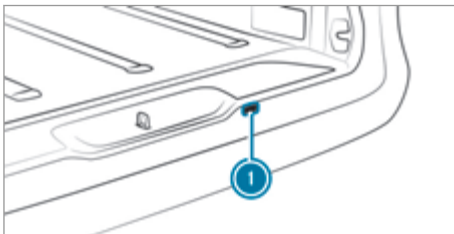

- ▶ Take the wheel wrench and the auxiliary tool for the spare wheel winch out of the vehicle tool kit (→ page 253).
- ▶ Carefully prise off cover cap ① with a suitable tool, e.g. a screwdriver. Be careful not to damage the paintwork or the covering cap when doing so.

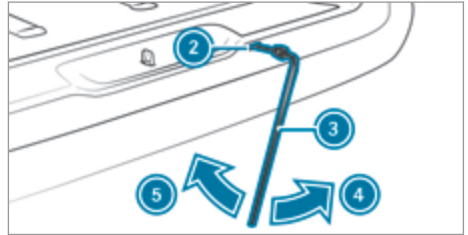

- ▶ Push auxiliary tool ② through the opening into the space wheel winch guide.
- ▶ Attach wheel wrench ③ to auxiliary tool ② for the spare wheel winch.
- ▶ Turn wheel wrench ③ in the direction of arrow ⑤ until you feel resistance or until the friction clutch of the spare wheel winch overwinds. The spare wheel is lowered.

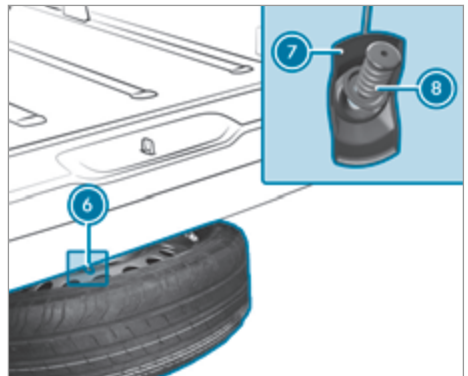

- ▶ Pull the spare wheel out from under the vehicle.
- ▶ Press cable ⑥ downwards and hold spring ⑧ at an angle against wheel gripper ⑦. Wheel gripper ⑦ is released.
- ▶ Pull wheel gripper ⑦ out of the wheel brace.

## Fitting the spare wheel under the rear of the vehicle

- ❗ Light-alloy wheels cannot be transported under the vehicle. In this case, transport the light-alloy wheel in the load compartment, and only turn up cable ⑥.
- ▶ Take wheel wrench ③ and auxiliary tool ② for the spare wheel lifter out of the vehicle tool kit (→ page 253).
- ▶ Place the wheel on the ground with the wheel brace pointing upwards.
- ▶ Guide wheel gripper ⑦ at an angle on wire ⑥ from above into the wheel brace.
- ▶ Slide the wheel slightly under the vehicle.
- ▶ Attach wheel wrench ③ to auxiliary tool ② for the spare wheel lifter.
- ▶ Turn wheel wrench ③ in the direction of arrow ④ until you feel resistance and the friction clutch of the spare wheel winch overwinds in jerks.  
The wheel is firmly secured to the underside of the vehicle.
- ▶ Pull wheel wrench ③ and auxiliary tool ② for the spare wheel lifter out of the opening for the spare wheel winch.
- ▶ Close the spare wheel winch opening with cover cap ①.
- ▶ Stow wheel wrench ③ and auxiliary tool ② for the spare wheel lifter in the vehicle tool kit.

### Information on the technical data

The technical data was determined in accordance with EU Directives. The given data only applies to vehicles with standard equipment. You can obtain further information at a qualified specialist workshop.

**Only for certain countries:** you can find vehicle-specific vehicle data in the COC documents (CERTIFICATE OF CONFORMITY). These documents are supplied when the vehicle is delivered.

### On-board electronics

#### Notes on work on the engine electronics

**NOTE** Premature wear through improper maintenance

Improper maintenance may cause vehicle components to wear more quickly and the vehicle's operating permit may be invalidated.

- ▶ Always have work on the engine electronics and related components carried out at a qualified specialist workshop.

### Two-way radios

#### Installation notes for two-way radios

**WARNING** Risk of accident due to improper work on two-way radios

If two-way radios are manipulated or retrofitted incorrectly, the electromagnetic radiation from the two-way radios can interfere with the vehicle electronics and jeopardise the operating safety of the vehicle.

- ▶ You should have all work on electrical and electronic components carried out at a qualified specialist workshop.

**WARNING** Risk of accident due to improper operation of two-way radios

If you use two-way radios in the vehicle improperly, their electromagnetic radiation can disrupt the vehicle's electronics. This is the case in the following situations, in particular:

- The two-way radio is not connected to an exterior aerial.
- The exterior aerial is fitted incorrectly or is not a low-reflection aerial.

This could jeopardise the operating safety of the vehicle.

- ▶ Have the low-reflection exterior aerial fitted at a qualified specialist workshop.
- ▶ When operating two-way radios in the vehicle, always connect them to the low-reflection exterior aerial.

**NOTE** Invalidation of the operating permit due to failure to comply with the instructions for installation and use

The operating permit may be invalidated if the instructions for installation and use of two-way radios are not observed.

- ▶ Only use approved frequency bands.
- ▶ Observe the maximum permissible output power in these frequency bands.
- ▶ Only use approved aerial positions.

Use Technical Specification ISO/TS 21 609 (Road Vehicles - EMC guidelines for installation of after-market radio frequency transmitting equipment) when retrofitting two-way radios. Comply with the legal requirements for detachable parts.

If your vehicle has fittings for two-way radio equipment, use the power supply or aerial connections intended for use with the fittings. Observe the manufacturer's supplements during installation.

#### Two-way radio transmission output

The maximum transmission outputs (PEAK) at the base of the aerial must not exceed the values in the following table:

#### Frequency band and maximum transmission output

Frequency band	Maximum transmission output
Short wave 3 – 54 MHz	100 W
4 m waveband 74 – 88 MHz	30 W
2 m waveband 144 – 174 MHz	50 W
Trunked radio system/ Tetra 380 – 460 MHz	10 W

Frequency band	Maximum transmission output
70 cm waveband 420 – 450 MHz	35 W
Two-way radio (2G/3G/4G)	10 W

The following devices can be used in the vehicle without restrictions:

- two-way radios with a maximum transmission output of up to 100 mW
- two-way radios with transmitter frequencies in the 380 – 410 MHz frequency band and a maximum transmission output of up to 2 W (trunked radio system/Tetra)
- mobile phones (2G/3G/4G)

There are no restrictions when positioning the aerial on the outside of the vehicle for the following frequency bands:

- Trunked radio system/Tetra
- 70 cm waveband
- 2G/3G/4G

### Regulatory radio identifications and notes

#### Regulatory radio identification of small components

Manufacturer information on wireless vehicle components can be found under the heading "Regulatory radio identification" in the Digital Operating Instructions in the vehicle, on the Internet and in the app.

#### Regulatory radio identifications – Indonesia

Manufacturer information on wireless vehicle components for Indonesia can be found under the heading "Regulatory radio identification – Indonesia" in the Digital Operating Instructions in the vehicle, on the Internet and in the app.

- ⓘ These are not small components. Information on small components can be found under the heading "Regulatory radio identification of small components."

### Vehicle identification plate, vehicle identification number (VIN) and engine number

#### Vehicle identification plate

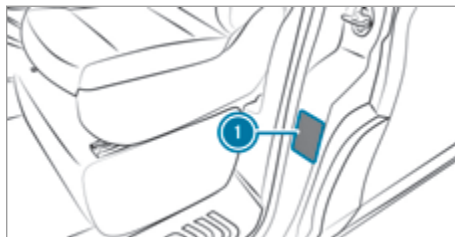

Vehicle identification plate ⓘ is on the B-pillar on the driver's side.

- ⓘ The data is vehicle-specific and can differ from that shown. Always observe the specifications on your vehicle's identification plate.

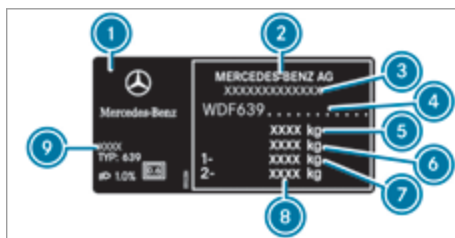

Example: vehicle identification plate

- ① Vehicle identification plate
- ② Vehicle manufacturer
- ③ EU general operating permit number (only for certain countries)
- ④ VIN (vehicle identification number)
- ⑤ Permissible gross mass (kg)
- ⑥ Permissible gross mass of vehicle combination (kg) (for specific countries only)
- ⑦ Permissible front axle load (kg)
- ⑧ Permissible rear axle load (kg)
- ⑨ Paint code

## Engraved VIN in the engine compartment

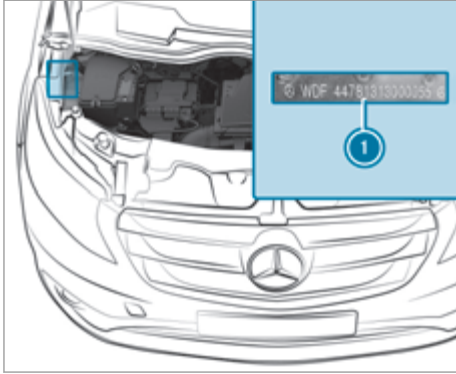

VIN **i** is engraved into the longitudinal member in the engine compartment next to the fuse box.

### Engine number

The engine number is stamped onto the crankcase. You can obtain further information from a qualified specialist workshop.

## Operating fluids and capacities

### Notes on operating fluids

**⚠ WARNING** Risk of injury from operating fluids harmful to your health

Operating fluids may be poisonous and harmful to your health.

- ▶ Observe the text on the original containers when using, storing or disposing of operating fluids.
- ▶ Always store operating fluids sealed in their original containers.
- ▶ Always keep children away from operating fluids.

**🌿 ENVIRONMENTAL NOTE** Environmental pollution due to disposing of operating fluids in a non-environmentally responsible manner

Incorrect disposal of operating fluids can cause considerable damage to the environment.

- ▶ Dispose of operating fluids in an environmentally responsible manner.

Operating fluids include the following:

- fuels
- exhaust gas aftertreatment additives, e.g. AdBlue®
- lubricants
- coolant
- brake fluid
- windscreen washer fluid
- climate control system refrigerants

Only use products which have been approved for your vehicle by Mercedes-Benz. Damage caused by the use of products that have not been approved is not covered by the Mercedes-Benz guarantee or goodwill gestures.

You can identify operating fluids approved by Mercedes-Benz by the following inscriptions on the container:

- MB-Freigabe (e.g. MB-Freigabe 229.51)
- MB-Approval (e.g. MB-Approval 229.51)

Further information on approved operating fluids is available at the following locations:

- In the Mercedes-Benz Specifications for Operating Fluids at <https://bevo.mercedes-benz.com> (by entering the designation)
- At a qualified specialist workshop

Additives for approved operating fluids are neither required nor permitted. Approved fuel additives are the exception. Additives can cause engine damage and must therefore not be added to the operating fluids.

The use of additives is always the responsibility of the vehicle operator. The use of additives may result in the restriction or loss of your warranty claims.

**⚠ WARNING** Risk of fire or explosion from fuel

Fuels are highly flammable.

- ▶ Fire, naked flames, smoking and creating sparks must be avoided.
- ▶ Before refuelling, switch off the vehicle and, if fitted, the stationary heater and keep switched off during filling.

**⚠ WARNING** Risk of injury from fuels

Fuels are poisonous and hazardous to your health.

- ▶ Do not swallow fuel or let it come into contact with skin, eyes or clothing.
- ▶ Do not inhale fuel vapour.
- ▶ Keep children away from fuel.
- ▶ Keep doors and windows closed during the refuelling process.

If you or other people come into contact with fuel, observe the following:

- ▶ Immediately rinse fuel off your skin with soap and water.
- ▶ If fuel comes into contact with your eyes, immediately rinse them thoroughly with clean water. Seek medical attention immediately.
- ▶ If you swallow fuel, seek medical attention immediately. Do not induce vomiting.
- ▶ Change immediately out of clothing that has come into contact with fuel.

## Fuel

### Notes on fuel quality for vehicles with petrol engines

Observe the notes on operating fluids (→ page 274).

#### **!** NOTE Damage due to incorrect fuel

Even small amounts of the wrong fuel could result in damage to the fuel system, engine and exhaust system.

- ▶ Only refuel using premium-grade unleaded petrol that conforms to European standard EN 228 or an equivalent specification.

This fuel may contain up to 10% ethanol by volume. Your vehicle is suitable for use with E10 fuel.

Never refuel with the following:

- Diesel
  - Petrol with more than 10% ethanol by volume, e.g. E15, E20, E85, E100
  - Petrol with more than 3% methanol by volume, e.g. M15, M30, M50, M85, M100
  - petrol with additives containing metal
- ▶ Do not mix such fuels with the fuel recommended for your vehicle.

If you have accidentally refuelled with the wrong fuel:

- ▶ Do not switch on the vehicle.
- ▶ Consult a qualified specialist workshop.

#### **!** NOTE Malfunction due to contaminated fuel

Impurities in the fuel can lead to malfunctions of the fuel system.

- ▶ If you are using drums or canisters to refuel the vehicle, you should filter the fuel before filling.

The following compatibility indications for fuel apply to your vehicle.



- ① For petrol with maximum 5% ethanol by volume
- ② For petrol with maximum 10% ethanol by volume

According to European standard EN 16942 you can find the compatibility indications at the following locations:

- On the vehicle on the information label in the fuel filler flap (→ page 148)
- Throughout Europe on the fuel dispenser or pump nozzles suitable for your vehicle

If the available fuel is not sufficiently low in sulphur, this can produce unpleasant odours.

The recommended octane number for your vehicle can be found on the information label in the fuel filler flap (→ page 148).

Further information on fuel can be obtained at a filling station or a qualified specialist workshop.

### Notes on additives in petrol

Observe the notes on operating fluids (→ page 274).

**!** **NOTE** Damage from use of unsuitable additives

Even small amounts of the wrong additive may lead to malfunctions.

▶ Only add cleaning additives recommended for Mercedes-Benz to the fuel.

Mercedes-Benz recommends using brand-name fuels with additives.

In some countries, the available fuel may not contain sufficient amounts of additives. Deposits could build up in the fuel injection system as a result.

In this case, in consultation with a Mercedes-Benz service centre, the fuel should be mixed with the cleaning additive recommended by Mercedes-Benz.

You must observe the notes and mixing ratios indicated on the tank.

### Notes on fuel quality for vehicles with diesel engines

#### General notes

Observe the notes on operating fluids (→ page 274).

**!** **WARNING** Risk of fire from fuel mixture

If you mix diesel fuel with petrol, the flash point of the fuel mixture is lower than that of pure diesel fuel.

- ▶ Never refuel using petrol in diesel engines.
- ▶ Never mix petrol with diesel fuel.

**!** **NOTE** Damage due to incorrect fuel

Even small amounts of the wrong fuel could result in damage to the fuel system, the engine and the emission control system.

▶ Only refuel using sulphur-free diesel fuel that conforms to European standard EN 590, or an equivalent specification. In countries without sulphur-free diesel fuel, refuel using only low-sulphur diesel fuel with a sulphur content less than 50 ppm.

Never refuel with one of the following fuels:

- Petrol
- Marine diesel
- Heating oil

- Pure fatty acid methyl ester or vegetable oil
- Paraffin or kerosene

If you have accidentally refuelled with the wrong fuel:

- ▶ Do not switch on the vehicle.
- ▶ Consult a qualified specialist workshop.

**!** **NOTE** Malfunction due to contaminated fuel

Impurities in the fuel can lead to malfunctions of the fuel system.

▶ If you are using drums or canisters to refuel the vehicle, you should filter the fuel before filling.

The following compatibility indications for fuel apply to your vehicle:

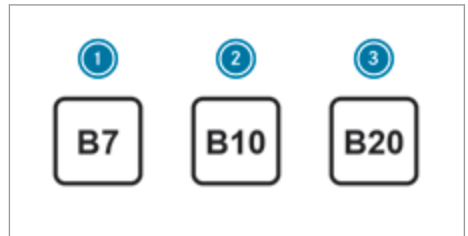

- ① For diesel fuel with a maximum of 7% by volume fatty acid methyl ester (bio-diesel)
  - ② For diesel fuel with a maximum of 10% by volume fatty acid methyl ester (bio-diesel)
  - ③ For diesel fuel with a maximum of 20% by volume fatty acid methyl ester (bio-diesel)
- i** **Only refill with diesel fuel containing a maximum of 10 or 20% by volume fatty acid methyl ester (bio-diesel) if the corresponding compatibility mark is present in your fuel filler flap.**

In accordance with the European standard EN 16942, you will find the compatibility marks for fuel in the following places:

- On the vehicle on the information label in the fuel filler flap (→ page 148)
- Throughout Europe on the fuel dispenser or pump nozzles suitable for your vehicle

#### XTL-compatible vehicles

Alternatively, you can also refuel with paraffinic diesel fuel (e.g. HVO=hydrogenated vegetable oil, GTL=Gas-To-Liquid), that complies with the Euro-

pean standard EN 15940. Paraffinic diesel fuels are collectively known as XTL.

In accordance with European standard EN 16942, the following fuel compatibility marks apply to your XTL-compatible vehicle:



② For paraffinic diesel fuel

ⓘ **Refuel with paraffinic diesel fuels to EN 15940 only if the appropriate compatibility mark is present in your fuel filler flap.**

### B10 fatty acid methyl ester

Mercedes-Benz approves the use of B10 fatty acid methyl ester (low-sulphur diesel fuel with a maximum of up to 10% by volume fatty acid methyl ester) for all vehicles with Euro 5 diesel engines with Common Rail Direct Injector (CDI).

Pure fatty acid methyl ester and diesel fuel that has a higher percentage of fatty acid methyl ester, e.g. B20, could damage the fuel system and the engine.

The identification of the fatty acid methyl ester on the fuel dispenser must clearly indicate that it fulfils the standard for low-sulphur diesel fuel. If the identification is not clear, do not refuel.

### Sulphur content

**!** **NOTE** Damage to the emission control system for vehicles with diesel particulate filters

If you use diesel fuel with a sulphur content that is too high, the emission control system may be damaged.

▶ In countries without sulphur-free diesel fuel, refuel using only low-sulphur diesel fuel with a sulphur content less than 50 ppm.

**Vehicle without diesel particulate filter:** In countries in which only diesel fuel with a higher sulphur content is available, the vehicle's engine oil change is carried out at shorter intervals. Further informa-

tion on oil change intervals can be obtained at a qualified specialist workshop.

Information about current country-specific sulphur content is available:

- At any Mercedes-Benz service centre
- At <https://bevo.mercedes-benz.com> under the specifications on Sheet Number 136.2

### Notes on low outside temperatures

Refuel your vehicle with as much winter diesel fuel as possible at the beginning of winter.

Before switching to winter diesel fuel, the fuel tank should be as empty as possible. When first refuelling with winter diesel fuel, keep the fuel level low, e.g. to reserve level. The next time you refuel, fill the fuel tank again normally.

Further information on fuel is available:

- At a filling station
- At a qualified specialist workshop

### Tank content and fuel reserve

The total capacity of the fuel tank may vary, depending on the vehicle equipment.

### Capacity

Model	Total capacity
Vehicles with a diesel engine:	Approximately 57 litres or Approx. 70 litres
Vehicles with a petrol engine	Approx. 70 litres
Model	Of which reserve fuel
Vehicles with a diesel engine:	Approximately 10 litres
Vehicles with a petrol engine	Approximately 13 litres

### AdBlue®

#### Notes on AdBlue®

Observe the notes on operating fluids (→ page 274).

AdBlue® is a water-soluble fluid for the exhaust gas aftertreatment of diesel engines.

It may be improper or punishable in some countries to operate a vehicle that uses no AdBlue® or

one that does not comply with the specifications of these operating instructions.

**!** **NOTE** Damage caused by additives in AdBlue® or by diluting AdBlue®

The AdBlue® exhaust gas aftertreatment system could be destroyed by the following:

- additives in AdBlue®
- diluting AdBlue®

- ▶ Only use AdBlue® in accordance with ISO 22241.
- ▶ Do not mix additives.
- ▶ Do not dilute AdBlue®.

**!** **NOTE** Damage and malfunctions caused by impurities in AdBlue®

Impurities in AdBlue® result in the following:

- higher emission values
- damage to the catalytic converter
- engine damage
- malfunctions in the AdBlue® exhaust gas aftertreatment system

- ▶ Avoid impurities in AdBlue®.

AdBlue® residue crystallises after some time and stain the affected surfaces. Clean the dirty surfaces with water as soon as possible.

If you open the AdBlue® tank, small amounts of ammonia vapour may be released. Do not inhale any ammonia vapours that may be released. Fill the AdBlue® tank only in well-ventilated areas.

### AdBlue® consumption and filling capacity

#### Filling capacities

The total capacity of the AdBlue® tank may vary, depending on the vehicle equipment.

#### Total capacity of AdBlue® tank

Vehicle	Total capacity
All models	11.5 litres, 24 litres or 25 litres

#### AdBlue® consumption

Like fuel consumption, AdBlue® consumption is highly dependent upon driving style and operating conditions. AdBlue® consumption is usually within a range of 1 and 5% of the fuel consumption. If

necessary, AdBlue® must be refilled in accordance with the instructions when the refill message is displayed in the instrument cluster. This may also be necessary between the scheduled maintenance.

Check the AdBlue® fill level before making journeys outside of Europe.

#### AdBlue® range and fill level

The AdBlue® fill level and range can be displayed via the on-board computer. The AdBlue® range shown depends strongly on the driving style and operating conditions. The actual range can therefore deviate from the range currently displayed in the on-board computer. The information given in the operator's manual in display messages regarding the reserve quantity and the minimum top-up quantity when the fuel tank is empty is also to be understood as guide values.

Display the AdBlue® range and level (→ page 187).

### Engine oil

#### Notes on engine oil

Observe the notes on operating fluids (→ page 274).



**!** **NOTE** Engine damage caused by an incorrect oil filter, incorrect oil or additives

- ▶ Do not use engine oils or oil filters other than those which meet the specifications necessary for the prescribed service intervals.
- ▶ Do not alter the engine oil or oil filter in order to achieve longer change intervals than prescribed.
- ▶ Do not use additives.
- ▶ Have the engine oil changed after the prescribed intervals.

Mercedes-Benz recommends having the oil changed at a qualified specialist workshop.

Only engine oils approved for Mercedes-Benz may be used in Mercedes-Benz engines.

Further information on engine oil and oil filter:

- In the Mercedes-Benz Specifications for Operating Fluids at <https://bevo.mercedes-benz.com> (by entering the designation)
- At a qualified specialist workshop

### Quality and capacity of engine oil

#### MB-Freigabe or MB-Approval

Petrol engines	MB-Freigabe or MB-Approval
All models	229.5, 229.6 <sup>1</sup>
Diesel engines	MB-Freigabe or MB-Approval
OM 651 Rear-wheel drive and all-wheel drive	228.51, 229.31, 229.51, 229.52 <sup>1</sup>
OM 654 Rear-wheel drive and all-wheel drive	228.51, 229.31, 229.51, 229.52, 229.71 <sup>1</sup>
1 recommended for lowest possible fuel consumption (lowest SAE viscosity class in each case; observe possible restrictions of the approved SAE viscosity classes)	

To achieve the lowest possible fuel consumption, it is recommended to use the engine oil specifications marked in the table for the lowest SAE viscosity class. Observe any possible restrictions of the approved SAE viscosity classes.

-  If the engine oils listed in the table are not available, you may add a maximum 1.0 litre of the following engine oils once only:

Engine oils for one-time filling only in the exceptional cases:

- **Vehicles with petrol engines:** MB-Freigabe or MB-Approval 229.3 or ACEA A3/B4
- **Vehicles with diesel engines:** MB-Freigabe or MB-Approval 228.5, 229.3 or 229.5/ACEA C3

#### Engine oil filling capacity

Petrol engines	Capacity
All models	Approximately 7.7 litres

Diesel engines	Capacity
OM 651 Rear-wheel drive and all-wheel drive	Approximately 8.5 litres
OM 654 Rear-wheel drive and all-wheel drive	Approximately 9.0 litres

#### Notes on brake fluid

Observe the notes on operating fluids (→ page 274).

 **WARNING** Risk of an accident due to vapour pockets forming in the brake system

The brake fluid constantly absorbs moisture from the air. This lowers the boiling point of the brake fluid. If the boiling point is too low, vapour pockets may form in the brake system when the brakes are applied hard.

This impairs the braking effect.

- ▶ Have the brake fluid renewed at the specified intervals.

 **NOTE** Damage to paint, plastic or rubber by brake fluid

There is a risk of damage to property if brake fluid comes into contact with paint, plastic or rubber.

- ▶ If paint, plastic or rubber comes into contact with brake fluid, rinse with water immediately.

Observe the notes on paintwork/matt finish paintwork care (→ page 234).

Have the brake fluid renewed every two years at a qualified specialist workshop.

Only use brake fluid approved by Mercedes-Benz in accordance with MB-Freigabe or MB-Approval 331.0.

Information on brake fluid is available at the following locations:

- in the Mercedes-Benz Specification for Operating Fluids 331.0
  - At <https://bevo.mercedes-benz.com>
  - In the Mercedes-Benz BeVo app
- At a qualified specialist workshop

## Coolant

### Notes on coolant

Observe the notes on operating fluids (→ page 274).

**⚠ WARNING** Risk of fire- and injury from antifreeze

If antifreeze comes into contact with hot component parts in the engine compartment, it may ignite.

- ▶ Allow the vehicle to cool down before you top up the antifreeze.
- ▶ Make sure that no antifreeze spills out next to the filler opening.
- ▶ Thoroughly clean the antifreeze from component parts before starting the vehicle.

**! NOTE** Damage caused by incorrect coolant

- ▶ Only add coolant that has been premixed with the required antifreeze protection.

Information on coolant is available at the following locations:

- In the Mercedes-Benz Specification for Operating Fluids 320.1
  - At <https://bevo.mercedes-benz.com>
  - In the Mercedes-Benz BeVo app
- At a qualified specialist workshop

**! NOTE** Overheating at high outside temperatures

If an inappropriate coolant is used, the engine cooling system is not sufficiently protected against overheating and corrosion at high outside temperatures.

- ▶ Always use coolant approved for Mercedes-Benz.
- ▶ Observe the instructions in the Mercedes-Benz Specification for Operating Fluids 320.1.

**! NOTE** Paintwork damage due to coolant

- ▶ Do not spill coolant on painted surfaces.

Have the coolant regularly replaced at a qualified specialist workshop.

Note the proportion of anti-corrosion agent/antifreeze in the engine cooling system within the following temperature ranges:

- A minimum of 50% (antifreeze protection down to about -37°C)
- A maximum of 55% (antifreeze protection down to -45°C)

### Capacities, coolant

#### Engine cooling system

Model	Capacity
All models	Approx. 10.4 l
	Approx. 13.4 l on vehicles with auxiliary heating

### Windscreen washer fluid

#### Notes on windscreen washer fluid

Observe the notes on operating fluids (→ page 274).

**⚠ WARNING** - Risk of fire and injury due to windscreen washer concentrate

Windscreen washer concentrate is highly flammable. It could ignite if it comes into contact with hot engine component parts or the exhaust system.

- ▶ Make sure that no windscreen washer concentrate spills out next to the filler opening.

**! NOTE** Damage to the exterior lighting due to unsuitable windscreen washer fluid

Unsuitable windscreen washer fluids may damage the plastic surface of the exterior lighting.

- ▶ Only use windscreen washer fluids which are also suitable for use on plastic surfaces, e.g. MB SummerFit or MB WinterFit.

**! NOTE** Blocked spray nozzles caused by mixing windscreen washer fluids

- ▶ Do not mix MB SummerFit and MB WinterFit with other windscreen washer fluids.

Do not use distilled or de-ionised water. Otherwise, the fill level sensor may give a false reading.

Recommended windscreen washer fluid:

- Above freezing point: e.g. MB SummerFit
- Below freezing point: e.g. MB WinterFit

For the correct mixing ratio, refer to the information on the anti-freeze container.

Mix the washer fluid with windscreen washer fluid all year round.

## Refrigerant

### Notes on refrigerant

Observe the notes on operating fluids (→ page 274).

- ① Your vehicle's climate control system may be filled with the refrigerant R134a. The refrigerant R134a contains fluorinated greenhouse gas.

The refrigerant type of your vehicle can be found on the information label of the climate control system. The information label can be found on the radiator cross-member.

### **!** NOTE Damage due to incorrect refrigerant

If the incorrect refrigerant or refrigerant compressor oil (PAG oil) is used, this can damage the climate control system.

- ▶ Use only refrigerant and the PAG oil approved for your vehicle by Mercedes-Benz.
- ▶ Do not mix the approved PAG oil with another PAG oil.

Maintenance work, such as topping up the refrigerant or replacing components, may be carried out only by a qualified specialist workshop. All applicable regulations, as well as SAE standard J639, must be adhered to.

Have all work on the climate control system carried out at a qualified specialist workshop.



Example: refrigerant information label

- ① Symbols for hazard and service information
- ② Refrigerant capacity
- ③ Applicable standards
- ④ PAG oil part number
- ⑤ Refrigerant type

Symbols ① advise you of the following:

- Potential dangers
- The performance of maintenance work at a qualified specialist workshop

## Vehicle data

### Information on vehicle dimensions

The following section contains important technical data for your vehicle. Your vehicle documents contain further vehicle-specific and equipment-dependent technical data such as vehicle dimensions and weights.

Current technical data can also be found online at <https://www.mercedes-benz.com>

The values specified may vary as a result of the following variables:

- tyres
- loading
- condition of the suspension
- optional equipment

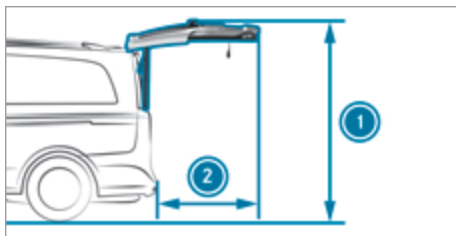

## Opening range

All models	
① Height of the tailgate when opened	2153 mm
② Opening range of the tailgate	1047 mm

## Vehicle dimensions

All models	
Vehicle length (compact version)	4895 mm
Vehicle length (long version)	5140 mm
Vehicle length (extra-long version)	5370 mm
Vehicle width including outside mirrors	2249 mm
Vehicle width excluding outside mirrors	1928 mm
Load width	1205 mm
Vehicle height	1900 mm – 1920 mm
Loading height	1297 mm – 1326 mm
Wheelbase (compact version)	3200 mm
Wheelbase (long version)	3200 mm
Wheelbase (extra-long version)	3430 mm

## Trailer hitch

### Notes on the trailer hitch

**⚠ WARNING** Risk of accident due to impermissible attachment of a trailer tow hitch

If you install a trailer tow hitch or other components, the longitudinal frame member is weakened and can break. The trailer may become detached from the vehicle.

There is a risk of an accident.

Only retrofit a trailer tow hitch if permissible.

Observe the notes on trailer operation (→ page 179).

Retrofitting a trailer hitch is only permissible if a towing capacity is specified in your vehicle documents.

Only use a trailer hitch which has been tested and specially approved by Mercedes-Benz for your vehicle.

### Overview of mounting dimensions

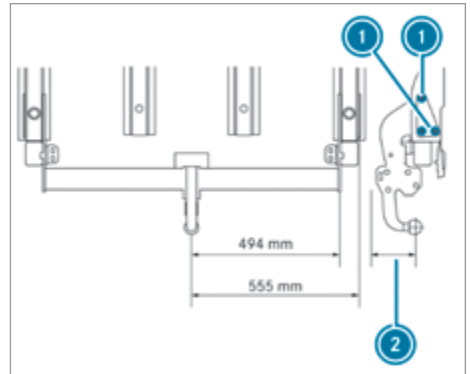

- ① Fastening points
- ② Distance from road surface

The distance between the trailer hitch and the road surface on an unladen vehicle depends on the vehicle type and the vehicle's equipment. Thus, it cannot be specified. The distance to the road surface of a laden vehicle is between 350 mm and 420 mm.

### Trailer loads

When towing a trailer, the permissible gross vehicle weight is increased by 100 kg for vehicles with passenger vehicle approval. The maximum permissible rear axle load may be exceeded by 150 kg when towing a trailer.

The road speed of the vehicle must be limited to a maximum of 100 km/h in accordance with Directive 92/21/EEC.

The permissible weights and loads which must not be exceeded can also be obtained from the following sources of information:

- Vehicle documents
- The type plates of the trailer hitch, trailer and vehicle

If the values differ, the lowest value applies.

When driving in mountainous areas, note that the engine power output, and with it the gradient climbing capability of the vehicle, decrease with increasing elevation.

The following values apply for a minimum start-off gradeability of 12%.

#### Maximum permissible gross combination weight, trailer loads and tongue weight

Permissible gross mass of vehicle combination	4800 kg to 5700 kg
Permissible towing capacity, braked	2000 kg to 2500 kg
Permissible towing capacity, unbraked	750 kg
Permissible tongue weight	100 kg

#### Lashing points and carrier systems

##### Loading capacity of the lashing points and tie-down eyes

Observe the notes on securing loads (→ page 219).

Nominal tensile load is the maximum permissible pulling force on the lashing point.

#### Guide rails

The nominal tensile load of the lashing points of a guide rail is 350 daN if you observe the following:

- the load on the load compartment floor is secured to two lashing points on the rail
- the distance to the nearest load-securing point on the same rail is approximately 1 m

#### Information about roof luggage racks

Observe the notes on the carrier systems (→ page 224).

**!** **NOTE** Damage due to exceeding the maximum permissible roof load

If the weight of the roof luggage, including the roof luggage rack, exceeds the maximum permissible roof load, this can cause damage to the vehicle.

- ▶ Do not exceed the maximum permissible roof load.

- ▶ Arrange the supporting feet of the roof luggage rack at an even distance from each other.
- ▶ Install the basic carrier bars for rail in front of and behind the mid-section support.

#### Maximum roof load / pairs of roof rack supports

Maximum roof load	Minimum number of pairs of supports
150 kg	3

This information applies if the load is distributed evenly across the entire roof area.

If the roof luggage rack is shorter, reduce the load proportionately. The maximum permitted load per pair of roof rack supports is 50 kg. The maximum permitted load of basic carrier bars for rail is 100 kg.

The driving, braking and steering characteristics of the vehicle will change with the type of load, the weight and the centre of gravity of the load. Comply with the loading guidelines and further information about load distribution (→ page 218).

## Display messages

### Introduction

#### Notes on display messages

**⚠ WARNING** Risk of accident due to an instrument cluster malfunction

If the instrument cluster has failed or malfunctioned, you may not notice restrictions to safety-relevant system functions.

The operating safety of your vehicle may be impaired.

- ▶ Drive on carefully.
- ▶ Have the vehicle checked immediately at a qualified specialist workshop.

The on-board computer shows messages and warnings from specific systems on the instrument cluster display. Ensure that your vehicle is operating safely at all times.

If you are uncertain regarding the operational safety of your vehicle, park the vehicle safely as soon as possible. Inform a qualified specialist workshop.

Display messages with graphic symbols are simplified in the Owner's Manual and may differ from the symbols on the display.

The display shows high-priority display messages in red. A warning tone will also sound for specific display messages.

Please act in accordance with the display messages and follow the additional notes in this Owner's Manual.

You can hide low-priority display messages using the **OK** or **←** steering-wheel button. The display messages will be saved to the message memory. Rectify the cause of a display message as quickly as possible.

High-priority display messages cannot be hidden. The display will show these display messages permanently until the cause of the display message has been rectified.

#### Calling up saved display messages

The on-board computer saves specific display messages to the message memory. You can call up the saved display messages. Use the buttons on the steering wheel.

- ▶ Press the **🏠** button to call up the list of menus.

- ▶ With the **◀** or **▶** button, select the **Service** menu.

- ▶ With the **▼** or **▲** button, select **Announcements**.

The bar will show the number of saved messages.

- ▶ Press **OK** to confirm.

The first saved display message will be displayed.

If there are no display messages, the display will show **No messages**.

- ▶ Press the **▼** or **▲** button to scroll through the display messages.

All saved display messages are numbered in the message memory. The current message number is shown on the lowest bar of the display as a means of orientation, together with the number of saved display messages.

- ▶ Press **↩** to exit the display messages screen.

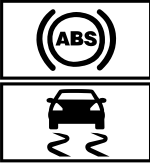
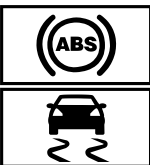

## Safety systems







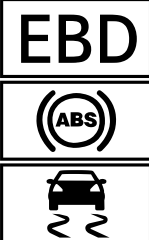

Display messages	Possible causes/consequences and ► Solutions
 <p data-bbox="87 375 313 422">inoperative See Owner's Manual</p>	<p data-bbox="364 204 991 252">* ABS, BAS, Hill Start Assist and ESP® as well as its driving safety systems are unavailable due to a malfunction.</p> <p data-bbox="380 263 1002 311">ATTENTION ASSIST is deactivated and other driving systems could be automatically deactivated.</p> <p data-bbox="380 322 957 370">The brake system continues to function normally, but without the functions listed above.</p> <div data-bbox="386 391 1002 454" style="border: 1px solid black; padding: 5px;"> <p data-bbox="397 395 980 450"><b>▲ WARNING</b> Risk of skidding if ABS and ESP® are malfunctioning</p> </div> <div data-bbox="386 459 1002 518" style="border: 1px solid black; padding: 5px;"> <p data-bbox="397 464 980 512">The wheels may block during braking and ESP® does not perform any vehicle stabilization.</p> </div> <div data-bbox="386 523 1002 598" style="border: 1px solid black; padding: 5px;"> <p data-bbox="397 528 968 598">The steerability and braking characteristics are heavily impaired and the braking distance may increase. In addition, other driving safety systems are switched off.</p> </div> <ul data-bbox="397 606 968 694" style="list-style-type: none"> <li data-bbox="397 606 588 630">► Drive on carefully.</li> <li data-bbox="397 638 968 694">► Have ABS and ESP® checked immediately at a qualified specialist workshop.</li> </ul> <ul data-bbox="380 710 1002 798" style="list-style-type: none"> <li data-bbox="380 710 576 742">► Drive on carefully.</li> <li data-bbox="380 750 1002 798">► Have ABS and ESP® checked immediately at a qualified specialist workshop.</li> </ul>
 <p data-bbox="87 984 280 1032">currently unavailable See Owner's Manual</p>	<p data-bbox="364 813 991 861">* ABS, BAS, Hill Start Assist and ESP® as well as its driving safety systems are temporarily unavailable.</p> <p data-bbox="380 873 1002 920">ATTENTION ASSIST is deactivated and other driving systems could be automatically deactivated.</p> <p data-bbox="380 932 991 979">The on-board electrical system voltage may be insufficient, for example.</p> <p data-bbox="380 991 957 1038">The brake system continues to function normally, but without the functions listed above.</p> <div data-bbox="386 1059 1002 1123" style="border: 1px solid black; padding: 5px;"> <p data-bbox="397 1064 980 1118"><b>▲ WARNING</b> Risk of skidding if ABS and ESP® are malfunctioning</p> </div> <div data-bbox="386 1128 1002 1187" style="border: 1px solid black; padding: 5px;"> <p data-bbox="397 1133 980 1181">The wheels may block during braking and ESP® does not perform any vehicle stabilization.</p> </div> <div data-bbox="386 1192 1002 1267" style="border: 1px solid black; padding: 5px;"> <p data-bbox="397 1197 968 1267">The steerability and braking characteristics are heavily impaired and the braking distance may increase. In addition, other driving safety systems are switched off.</p> </div> <ul data-bbox="397 1275 968 1362" style="list-style-type: none"> <li data-bbox="397 1275 588 1299">► Drive on carefully.</li> <li data-bbox="397 1307 968 1362">► Have ABS and ESP® checked immediately at a qualified specialist workshop.</li> </ul> <ul data-bbox="380 1378 1002 1487" style="list-style-type: none"> <li data-bbox="380 1378 980 1442">► Drive on carefully and, on a suitable stretch of road, make some slight steering movements at a speed above 20 km/h.</li> <li data-bbox="380 1450 1002 1487">► Check whether the display message has disappeared and ESP® is operational.</li> </ul>







Display messages	Possible causes/consequences and ► Solutions
	<p>If the display message continues to be shown:</p> <ul style="list-style-type: none"> <li>► Drive on carefully.</li> <li>► Consult a qualified specialist workshop immediately.</li> </ul>
<p>Front-passenger airbag disabled See Owner's Manual</p>	<p>* The front passenger airbag is disabled while the vehicle is in motion even though an adult or a person with a corresponding build is occupying the front passenger seat.</p> <p>If additional forces are applied to the seat or the front passenger is not sitting on the seat surface properly (→ page 36), the weight the system detects may be too low.</p> <div style="border: 1px solid black; padding: 5px; margin: 10px 0;"> <p><b>⚠ WARNING</b> - Risk of injury or even fatal injury when the front passenger airbag is disabled</p> <p>If the front passenger airbag is disabled, It will not be deployed in the event of an accident and cannot perform its intended protective function.</p> <p>A person in the front passenger seat could then, for example, come into contact with the vehicle interior, especially if the person is sitting too close to the dashboard.</p> <ul style="list-style-type: none"> <li>► Be aware of the status of the front passenger airbag both before and during the journey.</li> </ul> </div> <ul style="list-style-type: none"> <li>► Stop the vehicle immediately in accordance with the traffic conditions.</li> <li>► Secure the vehicle against rolling away.</li> <li>► Ensure that no objects have become trapped beneath the front passenger seat.</li> <li>► Switch off the vehicle.</li> <li>► The front passenger must get out of the vehicle.</li> <li>► Make sure that the front passenger seat is unoccupied, close the front passenger door and switch on the vehicle.</li> <li>► Observe the PASSENGER AIRBAG OFF indicator lamp on the centre console and the display messages.</li> <li>► With the seat unoccupied and the vehicle switched on, check the following: <ul style="list-style-type: none"> <li>• The PASSENGER AIRBAG OFF indicator lamp must light up continuously. If the indicator lamp is lit, the automatic front passenger airbag actuation has disabled the front passenger airbag (→ page 36).</li> <li>• The display must not show the messages <a href="#">Front-passenger airbag enabled See Owner's Manual</a> or <a href="#">Front-passenger airbag disabled See Owner's Manual</a>.</li> </ul> </li> <li>► Wait for at least one minute until the necessary system checks have been completed.</li> <li>► Ensure that the display does not show either of the two display messages about the front passenger airbag.</li> </ul> <p>If these conditions are met, the front passenger seat can be occupied again.</p>







Display messages	Possible causes/consequences and ► Solutions
	<p>If these conditions are not met, the automatic front passenger airbag actuation is malfunctioning.</p> <p>► Consult a qualified specialist workshop immediately.</p> <p>Further information on airbag shutoff can be found under "Automatic front passenger airbag actuation" (→ page 36).</p>
<p>Front-passenger airbag enabled See Owner's Manual</p>	<p>* The front passenger airbag is enabled while the vehicle is in motion although:</p> <ul style="list-style-type: none"> <li>• the front passenger seat is occupied by a child in a child restraint system or a person of small stature.</li> <li>or</li> <li>• the front passenger seat is not occupied.</li> </ul> <p>The system may detect objects or forces that are adding to the weight applied to the seat.</p> <div style="border: 1px solid black; padding: 5px; margin: 10px 0;"> <p><b>⚠ WARNING</b> Risk of injury or death when using a rearward-facing child restraint system while the front passenger airbag is enabled</p> </div> <p>If you secure a child in a rearward-facing child restraint system on the front passenger seat and the PASSENGER AIR BAG OFF indicator lamp is off, the front passenger airbag can deploy in the event of an accident.</p> <p>The child could be struck by the airbag.</p> <ul style="list-style-type: none"> <li>► Always ensure that the front passenger airbag is disabled. The PASSENGER AIR BAG OFF indicator lamp must be lit.</li> <li>► NEVER use a rearward-facing child restraint system on a seat with an ENABLED FRONT AIRBAG. This can result in the DEATH of or SERIOUS INJURY to the CHILD.</li> </ul> <ul style="list-style-type: none"> <li>► Stop the vehicle immediately in accordance with the traffic conditions.</li> <li>► Secure the vehicle against rolling away.</li> <li>► Ensure that no objects have become trapped beneath the front passenger seat.</li> <li>► Switch off the vehicle.</li> <li>► Open the front passenger door.</li> <li>► Remove the child and the child restraint system from the front passenger seat.</li> <li>► Make sure there are no objects applying additional weight to the seat. The system may otherwise detect the additional weight and interpret the vehicle occupant's weight on the front passenger seat as greater than it actually is.</li> <li>► Make sure that the front passenger seat is unoccupied, close the front passenger door and switch on the vehicle.</li> <li>► Observe the PASSENGER AIRBAG OFF indicator lamp on the centre console and the display.</li> </ul>

Display messages	Possible causes/consequences and ► Solutions
	<p>► With the seat unoccupied and the vehicle switched on, check the following:</p> <ul style="list-style-type: none"> <li>• The PASSENGER AIRBAG OFF indicator lamp must light up continuously. If the indicator lamp is lit, the automatic front passenger airbag actuation has disabled the front passenger airbag.</li> <li>• The display must not show the messages <a href="#">Front-passenger airbag enabled See Owner's Manual</a> or <a href="#">Front-passenger airbag disabled See Owner's Manual</a>.</li> </ul> <p>► Wait for at least one minute until the necessary system checks have been completed.</p> <p>► Ensure that the display does not show either of the two display messages about the front passenger airbag.</p> <p>If these conditions are met, the front passenger seat can be occupied again. Observe the notes on seat occupancy recognition and the result of the classification of the automatic front passenger airbag actuation (→ page 36).</p> <p>If these conditions are not met, the automatic front passenger airbag actuation is malfunctioning.</p> <p>► Fit the child restraint system to a suitable rear seat.</p> <p>or</p> <p>► Seat a person of small stature on a suitable rear seat.</p> <p>► Consult a qualified specialist workshop immediately.</p> <p>Further information on airbag shutoff can be found under "Automatic front passenger airbag actuation" (→ page 36).</p>
<p><a href="#">Check brake pad wear</a></p>	<p>* The brakepads have reached their wear limit.</p> <p>► Consult a qualified specialist workshop.</p>
<p>Vehicles with all-wheel drive:</p> <div style="border: 1px solid black; padding: 5px; width: fit-content; margin: 10px auto;">  </div> <p><a href="#">Caution Brakes overheated Drive carefully</a></p>	<p>* The brake system is overheating in vehicles with all-wheel drive. Traction control and braking power will be impaired.</p> <div style="background-color: #f0f0f0; padding: 5px; margin: 10px 0;"> <p><b>⚠ WARNING</b> Risk of accident due to overheated brake system</p> </div> <p>If you rest your foot on the brake pedal during while driving, the brake system may overheat. This increases the braking distance and the brake system may even fail.</p> <ul style="list-style-type: none"> <li>► Never use the brake pedal as a footrest.</li> <li>► Do not press the brake pedal and accelerator pedal simultaneously while driving.</li> </ul> <p>► Drive on carefully. When the brake system has cooled down, the display message will disappear. Traction control will then be fully operational again.</p>

Display messages	Possible causes/consequences and ► Solutions
 <p data-bbox="90 252 295 272">Check brake fluid level</p>	<p data-bbox="365 164 893 185">* There is insufficient brake fluid in the brake fluid reservoir.</p> <div data-bbox="384 204 1005 427" style="border: 1px solid gray; padding: 5px;"> <p data-bbox="395 212 949 233"><b>▲ WARNING</b> Risk of an accident due to low brake fluid level</p> <p data-bbox="395 248 972 296">If the brake fluid level is too low, the braking effect and the braking characteristics may be impaired.</p> <ul data-bbox="395 308 932 419" style="list-style-type: none"> <li data-bbox="395 308 932 355">► Stop the vehicle as soon as possible, paying attention to road and traffic conditions. Do not continue driving.</li> <li data-bbox="395 363 781 384">► Consult a qualified specialist workshop.</li> <li data-bbox="395 392 692 419">► Do not top up the brake fluid.</li> </ul> </div>
 <p data-bbox="90 703 311 751">inoperative See Owner's Manual</p>	<p data-bbox="365 451 983 523">* EBD is unavailable due to a malfunction. This means that ABS, BAS, Hill Start Assist and ESP® as well as its driving safety systems, for example, are also unavailable.</p> <p data-bbox="384 531 1000 579">ATTENTION ASSIST is deactivated and other driving systems could be automatically deactivated.</p> <p data-bbox="384 595 960 643">The brake system continues to function normally, but without the functions listed above.</p> <div data-bbox="384 659 1005 962" style="border: 1px solid gray; padding: 5px;"> <p data-bbox="395 667 955 715"><b>▲ WARNING</b> Risk of skidding if EBD, ABS and ESP® are malfunctioning</p> <p data-bbox="395 730 983 778">The wheels may block during braking and ESP® does not perform any vehicle stabilization.</p> <p data-bbox="395 794 972 866">The steerability and braking characteristics are heavily impaired and the braking distance may increase. In addition, other driving safety systems are switched off.</p> <ul data-bbox="395 882 949 962" style="list-style-type: none"> <li data-bbox="395 882 591 903">► Drive on carefully.</li> <li data-bbox="395 911 949 959">► Have the brake system checked immediately at a qualified specialist workshop.</li> </ul> </div>
 <p data-bbox="90 1074 311 1121">inoperative See Owner's Manual</p>	<p data-bbox="365 986 994 1066">* ESP®, BAS and Hill Start Assist are unavailable due to a malfunction. ATTENTION ASSIST is deactivated and other driving systems could be automatically deactivated.</p> <p data-bbox="384 1074 1000 1153">The brake system continues to function normally, but without the functions listed above. The wheels could therefore lock up at an early stage in the event of maximum full-stop braking, for example.</p> <p data-bbox="384 1161 1005 1209">This will severely impair steerability and braking. Braking distance may increase in an emergency braking situation.</p> <div data-bbox="384 1225 1005 1398" style="border: 1px solid gray; padding: 5px;"> <p data-bbox="395 1233 904 1257"><b>▲ WARNING</b> Risk of skidding if ESP® is malfunctioning</p> <p data-bbox="395 1273 988 1321">If ESP® is malfunctioning, ESP® cannot carry out vehicle stabilisation. In addition, other driving safety systems are switched off.</p> <ul data-bbox="395 1337 916 1393" style="list-style-type: none"> <li data-bbox="395 1337 591 1358">► Drive on carefully.</li> <li data-bbox="395 1366 916 1393">► Have ESP® checked at a qualified specialist workshop.</li> </ul> </div>

Display messages	Possible causes/consequences and ► Solutions
 <p data-bbox="109 252 303 300">currently unavailable See Owner's Manual</p>	<p data-bbox="389 164 1020 220">* ESP®, BAS and Hill Start Assist are unavailable due to a malfunction. Self-diagnosis is not yet complete, for example.</p> <p data-bbox="404 228 1020 276">ATTENTION ASSIST is deactivated and other driving systems could be automatically deactivated.</p> <p data-bbox="404 288 1020 360">The brake system continues to function normally, but without the functions listed above. The wheels could therefore lock up at an early stage in the event of maximum full-stop braking, for example.</p> <p data-bbox="404 373 1020 421">This will severely impair steerability and braking. Braking distance may increase in an emergency braking situation.</p> <div data-bbox="404 437 1020 612" style="border: 1px solid black; padding: 5px;"> <p data-bbox="415 448 927 472"><b>▲ WARNING</b> Risk of skidding if ESP® is malfunctioning</p> <p data-bbox="421 488 1009 536">If ESP® is malfunctioning, ESP® cannot carry out vehicle stabilisation. In addition, other driving safety systems are switched off.</p> <ul data-bbox="421 549 941 604" style="list-style-type: none"> <li data-bbox="421 549 613 572">► Drive on carefully.</li> <li data-bbox="421 580 941 604">► Have ESP® checked at a qualified specialist workshop.</li> </ul> </div> <p data-bbox="404 632 1020 727">► Drive carefully on a suitable stretch of road, making slight steering movements at a speed above 20 km/h. The functions mentioned above will be available again when the display message goes out.</p> <p data-bbox="404 756 815 780">If the display message continues to be shown:</p> <ul data-bbox="404 791 902 847" style="list-style-type: none"> <li data-bbox="404 791 598 815">► Drive on carefully.</li> <li data-bbox="404 823 902 847">► Consult a qualified specialist workshop immediately.</li> </ul>
 <p data-bbox="109 954 303 978">Release parking brake</p>	<p data-bbox="389 866 972 922">* The red  indicator lamp on the instrument cluster lights up. A warning tone also sounds.</p> <p data-bbox="404 930 994 978">You are driving with the parking brake applied or performing emergency braking using the parking brake.</p> <p data-bbox="404 991 809 1015">► Release the parking brake (→ page 153).</p>
 <p data-bbox="109 1121 331 1169">Parking brake See Owner's Manual</p>	<p data-bbox="389 1034 1003 1082">* The yellow  warning lamp lights up and the red  indicator lamp is off.</p> <p data-bbox="404 1090 1016 1137">The parking brake is malfunctioning, e.g. after the starter battery has been disconnected.</p> <p data-bbox="404 1150 658 1174"><b>Releasing the parking brake:</b></p> <ul data-bbox="404 1182 1020 1318" style="list-style-type: none"> <li data-bbox="404 1182 753 1206">► Switch the vehicle off and on again.</li> <li data-bbox="404 1214 1020 1262">► Depress the brake pedal and briefly pull the handle of the parking brake (→ page 153).</li> <li data-bbox="404 1270 1003 1318">► After around ten seconds, push down the handle of the parking brake.</li> </ul> <p data-bbox="404 1345 745 1369">If the yellow  warning lamp is off:</p> <ul data-bbox="404 1377 675 1401" style="list-style-type: none"> <li data-bbox="404 1377 675 1401">► Release the parking brake.</li> </ul> <p data-bbox="404 1430 792 1453">If the yellow  warning lamp remains lit:</p> <ul data-bbox="404 1461 583 1485" style="list-style-type: none"> <li data-bbox="404 1461 583 1485">► Do not drive on.</li> </ul>

Display messages	Possible causes/consequences and ► Solutions
	<ul style="list-style-type: none"> <li>► Secure the vehicle against rolling away.</li> <li>► <b>Vehicles with manual transmission:</b> engage first gear.</li> <li>► <b>Vehicles with automatic transmission:</b> shift the transmission to <b>P</b>.</li> <li>► Turn the front wheels towards the kerb.</li> <li>► Consult a qualified specialist workshop.</li> </ul> <p>* The yellow  warning lamp and the red  indicator lamp light up.</p> <p>The parking brake is malfunctioning.</p> <p><b>Releasing the parking brake:</b></p> <ul style="list-style-type: none"> <li>► Switch the vehicle off and on again.</li> <li>► Release the parking brake.</li> </ul> <p>If the parking brake still cannot be released:</p> <ul style="list-style-type: none"> <li>► Do not drive on.</li> <li>► Consult a qualified specialist workshop.</li> </ul> <p>* The red  indicator lamp flashes and the yellow  warning lamp lights up.</p> <p>The parking brake is malfunctioning.</p> <ul style="list-style-type: none"> <li>► Switch the vehicle off and on again.</li> <li>► Release or apply the parking brake.</li> </ul> <p>If the red  indicator lamp continues flashing:</p> <ul style="list-style-type: none"> <li>► Do not drive on.</li> <li>► Secure the vehicle against rolling away.</li> <li>► <b>Vehicles with manual transmission:</b> engage first gear.</li> <li>► <b>Vehicles with automatic transmission:</b> shift the transmission to <b>P</b>.</li> <li>► Turn the front wheels towards the kerb.</li> <li>► Consult a qualified specialist workshop.</li> </ul>
<div style="border: 1px solid black; padding: 5px; display: inline-block;">  </div> <p>Depress brake pedal to release</p>	<p>* The red  indicator lamp lights up.</p> <p>You have tried to release the parking brake without depressing the brake pedal.</p> <ul style="list-style-type: none"> <li>► Depress the brake pedal.</li> <li>► To release, pull the handle on the parking brake.</li> </ul>
<p>PRE-SAFE inoperative See Owner's Manual</p>	<p>* Important functions of PRE-SAFE® have failed. All other occupant safety systems, e.g. airbags, remain available.</p> <ul style="list-style-type: none"> <li>► Consult a qualified specialist workshop immediately.</li> </ul> <p>Information on these functions can be found under "PRE-SAFE® (anticipatory occupant protection)" (→ page 39).</p>

Display messages	Possible causes/consequences and ► Solutions
 <p>Restraint sys. malfunction Consult workshop</p>	<p>* The restraint system is malfunctioning. In addition, the  warning lamp on the instrument cluster lights up.</p> <p><b>▲ WARNING</b> Risk of injury due to malfunctions in the restraint system</p> <p>Components in the restraint system may be activated unintentionally or not deploy as intended in an accident.</p> <p>► Have the restraint system checked and repaired immediately at a qualified specialist workshop.</p> <p>Further information on the restraint system and its components can be found under "Occupant safety".</p>
 <p>Front left malfunction Consult workshop (example)</p>	<p>* The corresponding restraint system is malfunctioning. In addition, the  warning lamp on the instrument cluster lights up.</p> <p><b>▲ WARNING</b> Risk of injury due to malfunctions in the restraint system</p> <p>Components in the restraint system may be activated unintentionally or not deploy as intended in an accident.</p> <p>► Have the restraint system checked and repaired immediately at a qualified specialist workshop.</p> <p>► Consult a qualified specialist workshop immediately.</p>
 <p>Left windowbag malfunction Consult workshop (example)</p>	<p>* The corresponding window airbag is malfunctioning. In addition, the  warning lamp on the instrument cluster lights up.</p> <p><b>▲ WARNING</b> Risk of injury or fatal injury due to a malfunction in the windowbag</p> <p>The windowbag might be triggered unintentionally or might not be triggered at all in the event of an accident.</p> <p>► Have the windowbag checked and repaired immediately at a qualified specialist workshop.</p> <p>► Consult a qualified specialist workshop immediately.</p>

## Driving systems

Display messages	Possible causes/consequences and ► Solutions
<p>120 km/h Maximum speed exceeded</p>	<p>* For certain countries only: the maximum permissible speed has been exceeded.</p> <p>► Drive more slowly.</p>
 <p>ATTENTION ASSIST inoperative</p>	<p>* ATTENTION ASSIST has failed.</p> <p>► Consult a qualified specialist workshop.</p>

Display messages	Possible causes/consequences and ► Solutions
<b>ATTENTION ASSIST:</b> <b>Take a break!</b>	<p>* Based on certain criteria, ATTENTION ASSIST has detected fatigue or increasing lapses in concentration on the part of the driver.</p> <p>A warning tone also sounds.</p> <p>► If necessary, take a break.</p> <p>On long journeys, take regular and timely breaks that allow you to rest properly.</p>
<b>Active Distance Assist</b> <b>--- km/h</b>	<p>* An activation condition for Active Distance Assist DISTRONIC has not been fulfilled.</p> <p>► Comply with the activation conditions for Active Distance Assist DISTRONIC (→ page 163).</p>
<b>Active Distance Assist</b> <b>Off</b>	<p>* Active Distance Assist DISTRONIC has been deactivated (→ page 163).</p> <p>In the event of a deactivation not initiated by the driver, a warning tone sounds as well.</p>
<b>Active Distance Assist</b> <b>inoperative</b>	<p>* A warning tone also sounds. Active Distance Assist DISTRONIC is malfunctioning. In addition, BAS may have failed.</p> <p>► Consult a qualified specialist workshop.</p>
<b>Active Distance Assist</b> <b>and Limiter inoperative</b>	<p>* A warning tone also sounds. Active Distance Assist DISTRONIC and the limiter are malfunctioning.</p> <p>► Consult a qualified specialist workshop.</p>
<b>Active Distance Assist</b> <b>suspended</b>	<p>* You are accelerating. Active Distance Assist DISTRONIC does not intervene for the duration of the acceleration process.</p> <p>► Remove your foot from the accelerator pedal.</p> <p>Active Distance Assist DISTRONIC will be activated again.</p>
<b>Active Distance Assist</b> <b>currently unavailable</b> <b>See Owner's Manual</b>	<p>* A warning tone also sounds.</p> <p>Active Distance Assist DISTRONIC has been switched off and is temporarily non-operational.</p> <p>The following causes are possible:</p> <ul style="list-style-type: none"> <li>• The function is impaired due to heavy rain or snow.</li> <li>• The radar sensor system is temporarily non-operational, e.g. due to electromagnetic radiation close to TV or radio transmitting stations or other sources of radiation.</li> <li>• The system is outside the operating temperature range.</li> <li>• The on-board electrical system voltage is too low.</li> </ul> <p>If the causes mentioned above no longer apply, the display message will disappear and Active Distance Assist DISTRONIC will be operational again.</p> <p>If the display message does not disappear:</p> <p>► Stop in accordance with the traffic conditions.</p> <p>► Secure the vehicle against rolling away.</p> <p>► Restart the vehicle.</p>

Display messages	Possible causes/consequences and ► Solutions
Active Distance Assist available again	<p>* Active Distance Assist DISTRONIC is operational again following temporary non-availability. You can now switch Active Distance Assist DISTRONIC on again (→ page 164).</p>
Active Brake Assist Functions limited See Owner's Manual	<p>* Active Brake Assist is unavailable due to a malfunction.</p> <p>► Consult a qualified specialist workshop.</p>
Active Brake Assist Functions currently limited See Owner's Manual	<p>* Active Brake Assist is temporarily non-operational.</p> <p>The following causes are possible:</p> <ul style="list-style-type: none"> <li>• The sensors in the front bumper are dirty.</li> <li>• The function is impaired due to heavy rain or snow.</li> <li>• The radar sensor system is temporarily non-operational, e.g. due to electromagnetic radiation close to TV or radio transmitting stations or other sources of radiation.</li> <li>• The system is outside the operating temperature range.</li> <li>• The on-board electrical system voltage is too low.</li> </ul> <p>If the causes mentioned above no longer apply, the display message will disappear and Active Brake Assist will be operational again.</p> <p>If the display message does not disappear:</p> <p>► Stop in accordance with the traffic conditions.</p> <p>► Secure the vehicle against rolling away.</p> <p>► Switch off the vehicle.</p> <p>► Clean the sensors in the front bumper (→ page 235).</p> <p>► Start the vehicle again.</p>
Radar sensors dirty See Owner's Manual	<p>* A warning tone also sounds.</p> <p>At least one of the following driving systems or driving safety systems is temporarily non-operational or operational only on a restricted basis:</p> <ul style="list-style-type: none"> <li>• Active Brake Assist</li> <li>• Blind Spot Assist</li> <li>• Active Distance Assist DISTRONIC</li> </ul> <p>The following causes are possible:</p> <ul style="list-style-type: none"> <li>• The sensors in the radiator grille and/or in the bumpers are dirty.</li> <li>• The function of the driving system or driving safety system is impaired due to heavy rain or snow.</li> </ul> <p>If the causes mentioned above no longer apply, the display message will disappear and the driving systems or driving safety systems will be operational again.</p> <p>If the display message does not disappear:</p> <p>► Stop in accordance with the traffic conditions.</p> <p>► Secure the vehicle against rolling away.</p> <p>► Switch off the vehicle.</p> <p>► Clean the sensors in the following places:</p>

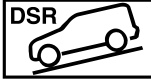
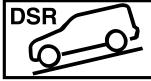
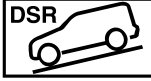

Display messages	Possible causes/consequences and ► Solutions
	<ul style="list-style-type: none"> <li>• In the radiator grille</li> <li>• In the front bumper</li> <li>• In the rear bumper</li> </ul> <p>► Start the vehicle again.</p>
Limiter --- km/h	<p>* The limiter cannot be activated while you have the accelerator pedal depressed beyond the point of resistance (kickdown).</p> <p>► If conditions permit, drive at a speed greater than 30 km/h and store the speed.</p>
Limiter passive	<p>* You have the accelerator pedal depressed beyond the point of resistance. Whilst you are accelerating, the limiter does not control your speed.</p> <p>► Remove your foot from the accelerator pedal. The limiter will be reactivated and will limit your speed.</p>
Cruise control --- km/h	<p>* An activation condition for cruise control has not been met. For example, you are aiming to store a speed below 30 km/h.</p> <p>► If conditions permit, drive at a speed greater than 30 km/h and store the speed.</p> <p>► Observe the activation conditions for cruise control (→ page 160).</p>
Cruise control and Limiter inoperative	<p>* A warning tone also sounds. Cruise control and the limiter are malfunctioning.</p> <p>► Consult a qualified specialist workshop.</p>
Blind Spot Assist not available when towing a trailer See Owner's Manual	<p>* Blind Spot Assist is switched off during trailer operation.</p> <p>► Acknowledge the display message with the <input type="button" value="OK"/> steering wheel button.</p>
Blind Spot Assist inoperative	<p>* Blind Spot Assist is malfunctioning.</p> <p>► Consult a qualified specialist workshop.</p>
Blind Spot Assist currently unavailable See Owner's Manual	<p>* Blind Spot Assist is temporarily non-operational. The following causes are possible:</p> <ul style="list-style-type: none"> <li>• The function is impaired due to heavy rain or snow.</li> <li>• The radar sensor system is temporarily non-operational, e.g. due to electromagnetic radiation close to TV or radio transmitting stations or other sources of radiation.</li> <li>• The system is outside the operating temperature range.</li> </ul> <p>If the causes mentioned above no longer apply, the display message will disappear and Lane Keeping Assist will be operational again.</p> <p>If the display message does not disappear:</p> <ul style="list-style-type: none"> <li>► Stop in accordance with the traffic conditions.</li> <li>► Secure the vehicle against rolling away.</li> <li>► Switch off the vehicle.</li> <li>► Restart the vehicle.</li> </ul>

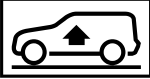
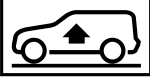





Display messages	Possible causes/consequences and ► Solutions
 — km/h	* DSR has been switched on but is not active as you are driving at a speed greater than 18 km/h. If you drive at a speed below 18 km/h, DSR will automatically brake again to the set speed.
 Off	* DSR was deactivated. If it was not deactivated by the driver, e.g. due to a malfunction of the ESP®, a warning tone also sounds.
 inoperative	* A warning tone also sounds. DSR is unavailable due to a malfunction. ► Consult a qualified specialist workshop.
Active Parking Assist cancelled	* An acoustic signal sounds as well. The active parking assistance systems have been cancelled and Active Parking Assist will automatically be aborted. You have touched the steering wheel, for example, or have driven at too high a speed. ► Steer and brake manually. ► Repeat the parking procedure if necessary. Comply with the deactivation conditions (→ page 172).
Active Parking Assist inoperative	* PARKTRONIC is malfunctioning or defective. ► Comply with the instructions and aids in "Function of PARKTRONIC"(→ page 167). ► If the display message continues to be displayed, consult a qualified specialist workshop: * Active Parking Assist is not available or is malfunctioning. ► Switch off the vehicle, wait a short while, then switch it on again. If the display message continues to be displayed, or if the display does not show the <b>P</b> symbol: ► Consult a qualified specialist workshop.
Lane Keeping Assist inoperative	* Lane Keeping Assist is malfunctioning. ► Consult a qualified specialist workshop.
Lane Keeping Assist currently unavailable See Owner's Manual	* Lane Keeping Assist has been switched off and is temporarily non-operational. The following causes are possible: <ul style="list-style-type: none"> <li>• The windscreen is dirty in the camera's field of vision.</li> <li>• Visibility is impaired due to heavy rain, snow or fog.</li> <li>• Lane markings are absent for a long period of time.</li> <li>• The lane markings are worn, dark or covered by dirt or snow, for example.</li> </ul> If the causes mentioned above no longer apply, the display message will disappear and Lane Keeping Assist will be operational again. If the display message does not disappear:



Display messages	Possible causes/consequences and ► Solutions
	<ul style="list-style-type: none"> <li>► Stop in accordance with the traffic conditions.</li> <li>► Secure the vehicle against rolling away.</li> <li>► Clean the windscreen.</li> </ul>
Traffic Sign Assist inoperative	<p>* Traffic Sign Assist is malfunctioning.</p> <ul style="list-style-type: none"> <li>► Consult a qualified specialist workshop.</li> </ul>
Traffic Sign Assist currently unavailable See Owner's Manual	<p>* Traffic Sign Assist has been switched off and is temporarily non-operational.</p> <p>The following causes are possible:</p> <ul style="list-style-type: none"> <li>• The windscreen is dirty in the camera's field of vision.</li> <li>• Visibility is impaired due to heavy rain, snow or fog.</li> </ul> <p>If the causes mentioned above no longer apply, the display message will disappear and Traffic Sign Assist will be operational again.</p> <p>If the display message does not go out:</p> <ul style="list-style-type: none"> <li>► Stop in accordance with the traffic conditions.</li> <li>► Secure the vehicle against rolling away.</li> <li>► Clean the windscreen.</li> </ul>
<div style="border: 1px solid black; padding: 5px; text-align: center; width: fit-content; margin: 0 auto;"> <b>HOLD</b> </div> <p>Off</p>	<p>* The HOLD function has been deactivated. The vehicle has started skidding.</p> <p>A warning tone also sounds.</p> <ul style="list-style-type: none"> <li>► Switch the HOLD function on again later (→ page 166).</li> </ul> <p>* The HOLD function has been deactivated. An activation condition will no longer be met when the brake pedal is depressed.</p> <p>A warning tone also sounds.</p> <ul style="list-style-type: none"> <li>► Check the activation conditions of the HOLD function (→ page 166).</li> </ul>
 <p>Lowering</p>	<p>* The vehicle level may be lowered for the following reasons:</p> <ul style="list-style-type: none"> <li>• You have selected a different drive program.</li> <li>• You have exceeded the speed limit.</li> </ul>
 <p>Vehicle rising</p>	<p>* The vehicle level may be raised for the following reasons:</p> <ul style="list-style-type: none"> <li>• You have selected a different drive program.</li> <li>• You have fallen below the speed limit.</li> </ul>
 <p>Compressor is cooling</p>	<p>* Due to frequent level changes within a short space of time, the compressor first needs to cool down to enable the selected driving level to be set.</p> <p>When the compressor has cooled down, the vehicle will continue rising to the selected vehicle level.</p> <ul style="list-style-type: none"> <li>► Drive on in a manner appropriate for the current level. Make sure that there is sufficient ground clearance.</li> </ul>

Display messages	Possible causes/consequences and ► Solutions
 <p data-bbox="112 252 314 300">Malfunction See Owner's Manual</p>	<p data-bbox="389 164 997 212">* AIRMATIC is functioning only to a limited extent. The vehicle's handling characteristics may be affected.</p> <div data-bbox="412 228 1028 443" style="border: 1px solid black; padding: 5px;"> <p data-bbox="417 236 966 292"><b>!</b> <b>NOTE</b> The tyres on the front axle or the fenders could be damaged by large steering movements</p> <ul style="list-style-type: none"> <li data-bbox="417 300 977 355">► Avoid large steering movements while driving and listen for scraping sounds.</li> <li data-bbox="417 363 997 435">► If you hear scraping sounds, pull over and stop the vehicle in accordance with the traffic conditions, and set a higher vehicle level if possible.</li> </ul> </div> <ul style="list-style-type: none"> <li data-bbox="406 459 988 515">► Drive in a manner appropriate for the current level, but do not exceed 80 km/h.</li> <li data-bbox="406 523 787 547">► Consult a qualified specialist workshop.</li> </ul>

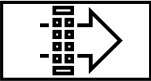

## Engine





Display messages	Possible causes/consequences and ► Solutions
 <p data-bbox="112 770 300 794">See Owner's Manual</p>	<p data-bbox="389 683 652 707">* A warning tone also sounds.</p> <p data-bbox="406 715 997 762">The battery is no longer being charged for one of the following reasons:</p> <ul style="list-style-type: none"> <li data-bbox="412 778 613 802">• defective alternator</li> <li data-bbox="412 810 580 834">• torn poly-V belt</li> <li data-bbox="412 842 703 866">• malfunction in the electronics</li> </ul> <ul style="list-style-type: none"> <li data-bbox="406 882 1022 962">► Stop the vehicle immediately in accordance with the traffic conditions and switch it off. Do not continue driving. If you do, the engine may overheat.</li> <li data-bbox="406 970 787 994">► Secure the vehicle against rolling away.</li> <li data-bbox="406 1002 787 1026">► Consult a qualified specialist workshop.</li> </ul>
 <p data-bbox="112 1129 288 1153">Clean the fuel filter</p>	<p data-bbox="389 1042 955 1066">* There is water in the fuel filter. The water must be drained off.</p> <ul style="list-style-type: none"> <li data-bbox="406 1074 787 1098">► Consult a qualified specialist workshop.</li> </ul>
 <p data-bbox="112 1265 300 1313">Coolant Stop vehicle Switch engine off</p>	<p data-bbox="389 1177 860 1201">* A warning tone also sounds. The coolant is too hot.</p> <div data-bbox="412 1217 1028 1501" style="border: 1px solid black; padding: 5px;"> <p data-bbox="417 1225 910 1249"><b>!</b> <b>WARNING</b> Risk of burns when opening the bonnet</p> <p data-bbox="417 1265 1011 1313">If you open the bonnet in the event of an overheated engine or fire in the engine compartment, the following situations may occur:</p> <ul style="list-style-type: none"> <li data-bbox="428 1329 837 1353">• You may come into contact with hot gases.</li> <li data-bbox="428 1361 1005 1409">• You may come into contact with other escaping hot operating fluids.</li> </ul> <ul style="list-style-type: none"> <li data-bbox="417 1425 977 1449">► Before opening the bonnet, allow the engine to cool down.</li> <li data-bbox="417 1457 972 1505">► In the event of a fire in the engine compartment, keep the bonnet closed and call the fire service.</li> </ul> </div>

Display messages	Possible causes/consequences and ► Solutions
	<p><b>▲ WARNING</b> Risk of scalding from hot coolant</p> <p>If you open the cap, you could be scalded.</p> <ul style="list-style-type: none"> <li>▶ Let the motor cool down before opening the cap.</li> <li>▶ When opening the cap, wear protective gloves and safety glasses.</li> <li>▶ Open the cap slowly to release pressure.</li> </ul> <ul style="list-style-type: none"> <li>▶ Stop the vehicle immediately in accordance with the traffic conditions and switch it off.</li> <li>▶ Monitor the coolant temperature display  on the instrument cluster.</li> <li>▶ Wait until the engine has cooled down.</li> <li>▶ Ensure that the air supply to the radiator is not obstructed.</li> <li>▶ Avoiding high engine loads, drive on to the nearest qualified specialist workshop. In doing so, ensure that the coolant temperature display remains below 120°C.</li> </ul>
	<p>* The fan motor is defective.</p> <ul style="list-style-type: none"> <li>▶ Check the coolant temperature display  on the instrument cluster.</li> </ul> <p>If the coolant temperature is below 120°C, you can continue driving to the nearest qualified specialist workshop.</p> <p>Avoid high engine loads, e.g. driving on hilly roads or stop-and-go driving.</p>
 Top up coolant See Owner's Manual	<p>* The coolant level is too low.</p> <p><b>! NOTE</b> Engine damage due to insufficient coolant</p> <ul style="list-style-type: none"> <li>▶ Avoid long journeys with insufficient coolant.</li> <li>▶ Top up with coolant, following the notes on coolant (→ page 231).</li> </ul> <p>If you frequently need to top up the coolant:</p> <ul style="list-style-type: none"> <li>▶ Have the engine cooling system checked at a qualified specialist workshop.</li> </ul>
 Replace air cleaner	<p>* The engine air filter is dirty and must be replaced.</p> <ul style="list-style-type: none"> <li>▶ Consult a qualified specialist workshop.</li> </ul>
 Check eng. oil lev. when next refuelling	<p>* A warning tone also sounds. The oil level in your vehicle has fallen to the minimum.</p> <p><b>! NOTE</b> Engine damage caused by driving with insufficient engine oil</p> <ul style="list-style-type: none"> <li>▶ Avoid long journeys with insufficient engine oil.</li> </ul>

Display messages	Possible causes/consequences and ► Solutions
	<ul style="list-style-type: none"> <li>► Check the oil level when next refuelling, at the latest (→ page 229).</li> <li>► If necessary, top up the engine oil (→ page 230).</li> </ul> <p>If engine oil frequently needs to be topped up:</p> <ul style="list-style-type: none"> <li>► Have the engine checked at a qualified specialist workshop.</li> </ul>
 <p>Engine oil level low. Stop vehicle. Switch engine off.</p>	<ul style="list-style-type: none"> <li>* The oil level is too low. There is a risk of engine damage.</li> <li>► Stop the vehicle immediately in accordance with the traffic conditions and switch it off.</li> <li>► Secure the vehicle against rolling away.</li> <li>► Check the oil level (→ page 229).</li> <li>► If necessary, top up the engine oil (→ page 230).</li> </ul>
 <p>Reserve fuel level</p>	<ul style="list-style-type: none"> <li>* The fuel supply has dropped into the reserve range. Operation of the auxiliary heating (stationary heater) is deactivated in the reserve range.</li> <li>► Refuel the vehicle.</li> </ul>
	<ul style="list-style-type: none"> <li>* There is very little fuel in the fuel tank.</li> <li>► It is absolutely essential to refuel at the nearest filling station.</li> </ul>

## AdBlue®

Display messages	Possible causes/consequences and ► Solutions
 <p>Refill AdBlue. See Owner's Manual.</p>	<ul style="list-style-type: none"> <li>* A warning tone also sounds. The AdBlue® level has fallen below the reserve range.</li> <li>► Top up with AdBlue® as soon as possible (→ page 150).</li> </ul>
 <p>Refill AdBlue. Emer. oper. in XXX km. See Owner's Manual.</p>	<ul style="list-style-type: none"> <li>* A warning tone also sounds. The AdBlue® level is sufficient only for the distance displayed. If you subsequently start the engine again, you will be able to drive the vehicle only at a maximum speed of 20 km/h for the distance shown. Engine management will then prevent the engine from starting.</li> <li>► Top up with AdBlue® immediately (→ page 150).</li> </ul>
 <p>Limp-home mode: 20 km/h. No start ... km. See Owner's Manual.</p>	<ul style="list-style-type: none"> <li>* A warning tone also sounds. The AdBlue® tank is empty. You can drive the distance shown at a maximum speed of 20 km/h. If you subsequently switch off the engine, the engine management system will prevent the engine from being started again. You will then be able to start the engine only once you have refilled the AdBlue® tank.</li> <li>► Stop the vehicle in accordance with the traffic conditions.</li> <li>► Top up with AdBlue® immediately (→ page 150).</li> </ul>

Display messages	Possible causes/consequences and ► Solutions
 <p>Refill AdBlue Start not possible</p>	<p>* A warning tone also sounds. The AdBlue® tank is empty. You can no longer start the engine.</p> <ul style="list-style-type: none"> <li>► Top up with at least 8 l AdBlue® (→ page 150).</li> <li>► Turn the key to position <b>2</b> in the ignition lock and wait for approximately one minute. The engine can be restarted once the engine management has detected the new level.</li> </ul>
 <p>AdBlue system Malfunction See Owner's Manual</p>	<p>* A warning tone also sounds. The AdBlue® system is malfunctioning.</p> <ul style="list-style-type: none"> <li>► Consult a qualified specialist workshop immediately.</li> </ul>
 <p>AdBlue malfunction Emer. oper. in XXX km See Owner's Manual</p>	<p>* A warning tone also sounds. The AdBlue® system is malfunctioning. The displayed distance is the maximum you can drive. If you subsequently start the engine again, you will be able to drive the vehicle only at a maximum speed of 20 km/h for the distance shown. After that, the engine management system will prevent the engine from being started again.</p> <ul style="list-style-type: none"> <li>► Consult a qualified specialist workshop immediately.</li> </ul>
 <p>Limp-home mode: 20 km/h No start ... km See Owner's Manual.</p>	<p>* A warning tone also sounds. The AdBlue® system is malfunctioning. You may continue to drive the displayed distance at a maximum speed of 20 km/h. If you subsequently switch off the engine, the engine management system will prevent the engine from being started again.</p> <ul style="list-style-type: none"> <li>► Drive on to a qualified specialist workshop.</li> <li>or</li> <li>► Stop the vehicle in accordance with the traffic conditions and consult a qualified specialist workshop.</li> </ul>
 <p>Refill AdBlue Start not possible</p>	<p>* A warning tone also sounds. The AdBlue® system is malfunctioning. You can no longer start the engine.</p> <ul style="list-style-type: none"> <li>► Inform a qualified specialist workshop immediately.</li> </ul>





## Tyres

Display messages	Possible causes/consequences and ► Solutions
<p>Rectify tyre pressure</p>	<p>* The tyre pressure is too low in at least one of the tyres, or the difference in tyre pressure between the individual wheels is too great.</p> <ul style="list-style-type: none"> <li>► Check the tyre pressure at the next opportunity (→ page 261).</li> <li>► Correct the tyre pressure as necessary.</li> <li>► Restart the tyre pressure monitoring system (→ page 261).</li> </ul>
<p>Check tyre(s)</p>	<p>* A warning tone also sounds. The tyre pressure in one or more tyres has dropped significantly.</p>

Display messages	Possible causes/consequences and ► Solutions
	<p><b>▲ WARNING</b> Risk of an accident due to insufficient tyre pressure</p> <ul style="list-style-type: none"> <li>• The tyres can burst.</li> <li>• The tyres can wear excessively and/or unevenly.</li> <li>• The driving characteristics as well as the steering and braking may be greatly impaired.</li> </ul> <p>You could then lose control of the vehicle.</p> <ul style="list-style-type: none"> <li>► Observe the recommended tyre pressures.</li> <li>► Adjust the tyre pressure if necessary.</li> </ul> <ul style="list-style-type: none"> <li>► Stop the vehicle without steering or braking suddenly. Pay attention to the traffic conditions.</li> <li>► Secure the vehicle against rolling away.</li> <li>► Check the tyres. If necessary, replace the wheel (→ page 264).</li> <li>► Check the tyre pressure (→ page 261). Correct the tyre pressure as necessary.</li> </ul>
Warning tyre defect	<p>* The tyre pressure in one or more tyres has dropped suddenly.</p> <p><b>▲ WARNING</b> Risk of an accident from driving with a flat tyre</p> <ul style="list-style-type: none"> <li>• The tyres can overheat and cause a fire.</li> <li>• The driving characteristics as well as the steering and braking may be greatly impaired.</li> </ul> <p>You could then lose control of the vehicle.</p> <ul style="list-style-type: none"> <li>► Do not drive on with a flat tyre.</li> <li>► Observe the notes on flat tyres.</li> </ul> <ul style="list-style-type: none"> <li>► Stop the vehicle without steering or braking suddenly. Pay attention to the traffic conditions.</li> <li>► Secure the vehicle against rolling away.</li> <li>► Check the tyres. If necessary, replace the wheel (→ page 264).</li> </ul>
Tyre press. monitor currently unavailable	<p>* Due to a source of radio interference, no signals from the tyre pressure sensors are being received. The tyre pressure monitoring system is temporarily malfunctioning.</p> <p>The tyre pressure monitoring system will restart automatically as soon as the cause has been rectified.</p>
Wheel sensor(s) missing	<p>* There is no signal from the tyre pressure sensor of at least one tyre. The display is not showing any pressure value for the tyre in question.</p> <ul style="list-style-type: none"> <li>► Have the faulty tyre pressure sensor replaced at a qualified specialist workshop.</li> </ul>
Tyre pressure monitor inoperative No wheel sensors	<p>* The wheels fitted do not have suitable tyre pressure sensors. The tyre pressure monitoring system is deactivated.</p> <ul style="list-style-type: none"> <li>► Fit wheels with suitable tyre pressure sensors. The tyre pressure monitoring system will switch on after a few minutes of driving.</li> </ul>





Display messages	Possible causes/consequences and ► Solutions
Tyre pressure monitor inoperative	<ul style="list-style-type: none"> <li>* The tyre pressure monitoring system is malfunctioning.</li> <li>► Consult a qualified specialist workshop.</li> </ul>

## Key



Display messages	Possible causes/consequences and ► Solutions
 Key does not belong to vehicle	<ul style="list-style-type: none"> <li>* You have inserted an incorrect key into the ignition lock.</li> <li>► Use the correct key.</li> </ul>
 Remove key	<ul style="list-style-type: none"> <li>* The key is in the ignition lock.</li> <li>► Remove the key.</li> </ul>
 Replace key	<ul style="list-style-type: none"> <li>* The key needs to be replaced.</li> <li>► Consult a qualified specialist workshop.</li> </ul>
 Change key batteries	<ul style="list-style-type: none"> <li>* The key battery is discharged.</li> <li>► Replace the battery (→ page 53).</li> </ul>

## Vehicle

Display messages	Possible causes/consequences and ► Solutions
Clutch overheated Avoid pulling away Engage/disengage clutch quickly if req.	<ul style="list-style-type: none"> <li>* A warning tone also sounds. The clutch is under heavy load and the permissible operating temperature of the clutch has been exceeded. Avoid frequent pulling away and driving at walking pace over extended distances.</li> <li>► Stop in accordance with the traffic conditions.</li> <li>► Secure the vehicle against rolling away.</li> <li>► Leave the engine running. The clutch will cool more quickly when the engine is running.</li> <li>or</li> <li>► If possible, continue driving at a steady speed.</li> <li>► Remove your foot from the clutch pedal and do not let the clutch slip. The clutch may also cool down during driving.</li> </ul> <p>Cooling down can take a few minutes. When the clutch has cooled down, the display message will disappear and the clutch will be fully operational again.</p>



Display messages	Possible causes/consequences and ► Solutions
	<ul style="list-style-type: none"> <li>* The tailgate is open. <ul style="list-style-type: none"> <li>► Close the tailgate.</li> </ul> </li> </ul>
	<ul style="list-style-type: none"> <li>* A warning tone also sounds. The bonnet is open. <div style="border: 1px solid black; padding: 5px; margin-top: 10px;"> <p><b>⚠ WARNING</b> Risk of accident due to driving with the bonnet unlocked</p> <p>The bonnet may open and block your view.</p> <ul style="list-style-type: none"> <li>► Never release the bonnet when driving.</li> <li>► Before every trip, ensure that the engine bonnet is locked.</li> </ul> </div> <ul style="list-style-type: none"> <li>► Stop the vehicle immediately in accordance with the traffic conditions.</li> <li>► Secure the vehicle against rolling away.</li> <li>► Close the bonnet.</li> </ul> </li> </ul>
	<ul style="list-style-type: none"> <li>* In addition, a warning tone sounds during the trip. The display shows the open door or doors. <ul style="list-style-type: none"> <li>► Close all the doors.</li> </ul> </li> </ul>
 <p data-bbox="112 818 288 842">Top up washer fluid</p>	<ul style="list-style-type: none"> <li>* The washer fluid level in the washer fluid reservoir has dropped below the minimum. <ul style="list-style-type: none"> <li>► Top up the washer fluid (→ page 232).</li> </ul> </li> </ul>
 <p data-bbox="112 957 341 1002">Power steering malfunction See Owner's Manual</p>	<ul style="list-style-type: none"> <li>* A warning tone also sounds. The power assistance for the steering could be malfunctioning. You may need to steer more forcefully. <ul style="list-style-type: none"> <li>► Carefully continue to a qualified specialist workshop and have the steering checked immediately.</li> </ul> </li> </ul>
<p data-bbox="112 1029 308 1053">Telephone No service</p>	<ul style="list-style-type: none"> <li>* Your vehicle is outside the transmission and receiver range of the mobile phone network provider.</li> </ul>
<p data-bbox="112 1093 324 1137">To start engine, shift to either P or N</p>	<ul style="list-style-type: none"> <li>* You have attempted to start the vehicle in transmission position <b>R</b> or <b>D</b>. <ul style="list-style-type: none"> <li>► Shift the transmission to position <b>P</b> or <b>N</b>.</li> </ul> </li> </ul>
<p data-bbox="112 1197 341 1241">Auxiliary battery malfunction</p>	<ul style="list-style-type: none"> <li>* The auxiliary battery for the transmission is no longer being charged. <ul style="list-style-type: none"> <li>► Consult a qualified specialist workshop.</li> </ul> </li> </ul>
<p data-bbox="112 1268 330 1313">Apply brake to deselect Park (P) position</p>	<ul style="list-style-type: none"> <li>* You have tried to shift the transmission to position <b>D</b>, <b>R</b> or <b>N</b> without applying the brake. <ul style="list-style-type: none"> <li>► Depress the brake pedal.</li> </ul> </li> </ul>
<p data-bbox="112 1364 324 1388">Apply brake to select R</p>	<ul style="list-style-type: none"> <li>* You have tried to shift the transmission to position <b>R</b> without applying the brake. <ul style="list-style-type: none"> <li>► Depress the brake pedal.</li> <li>► Shift the transmission position to <b>R</b>.</li> </ul> </li> </ul>

Display messages	Possible causes/consequences and ► Solutions
<p>N permanently active Risk of vehicle rolling</p>	<p>* A warning tone also sounds. While the vehicle is rolling or driving, the transmission was shifted to position <b>[N]</b>.</p> <ul style="list-style-type: none"> <li>► To stop, depress the brake pedal and, when the vehicle is at a standstill, shift the transmission to position <b>[P]</b>.</li> <li>► To continue your journey, shift the transmission to position <b>[R]</b> or <b>[D]</b>.</li> </ul>
<p>Risk of vehicle rolling Vehicle not in P</p>	<p>* A warning tone also sounds. The driver's door is open and the transmission is in position <b>[N]</b>, <b>[R]</b> or <b>[D]</b>.</p> <ul style="list-style-type: none"> <li>► Shift the transmission to position <b>[P]</b>.</li> <li>► Secure the vehicle against rolling away.</li> </ul>
<p>Without changing gear, consult workshop</p>	<p>* A warning tone also sounds. You can no longer change the transmission position due to a malfunction.</p> <p>If transmission position <b>[D]</b> has been selected:</p> <ul style="list-style-type: none"> <li>► Without changing the transmission position, consult a qualified specialist workshop.</li> </ul> <p>If transmission position <b>[P]</b>, <b>[R]</b> or <b>[N]</b> has been selected:</p> <ul style="list-style-type: none"> <li>► Inform a qualified specialist workshop.</li> </ul>
<p>Reversing not poss. Con- sult workshop</p>	<p>* The transmission is malfunctioning. Transmission position <b>[R]</b> cannot be selected.</p> <ul style="list-style-type: none"> <li>► Inform a qualified specialist workshop.</li> </ul>
<p>Transmission Malfunc- tion Stop</p>	<p>* The transmission is malfunctioning. The transmission automatically switches to neutral <b>[N]</b>.</p> <ul style="list-style-type: none"> <li>► Stop the vehicle immediately in accordance with the traffic conditions.</li> <li>► Shift the transmission to position <b>[P]</b>.</li> <li>► Inform a qualified specialist workshop.</li> </ul>
<p>Stop vehicle Leave engine running Wait Transmission cooling</p>	<p>* The transmission is overheating. Pulling away may be temporarily impaired or not possible.</p> <ul style="list-style-type: none"> <li>► Stop the vehicle immediately in accordance with the traffic conditions. Do not continue driving!</li> <li>► Leave the engine running.</li> <li>► Wait until the display message disappears before pulling away.</li> </ul>
<div data-bbox="98 1193 248 1273" data-label="Image"> </div> <p>inoperative Battery low</p>	<p>* The on-board electrical system voltage is too low. The hot-water auxiliary heater (stationary heater) has switched itself off or cannot be switched on.</p> <ul style="list-style-type: none"> <li>► Drive for an extended distance. The battery will be charged. The hot-water auxiliary heater (stationary heater) will be operational again as soon as the on-board electrical system voltage is sufficient.</li> </ul>

Display messages	Possible causes/consequences and ► Solutions
 <p data-bbox="109 252 325 300">inoperative Refuel vehicle</p>	<p data-bbox="387 164 1005 212">* There is too little fuel in the fuel tank. The hot-water auxiliary heater (stationary heater) cannot be switched on.</p> <ul style="list-style-type: none"> <li data-bbox="400 220 602 244">► Refuel the vehicle.</li> </ul>
 <p data-bbox="109 416 333 464">inoperative See Owner's Man.</p>	<p data-bbox="387 328 1000 352">* The hot-water auxiliary heater (stationary heater) is malfunctioning.</p> <ul style="list-style-type: none"> <li data-bbox="400 360 1016 456">► When the vehicle is stationary on a level surface and the engine has cooled down, make up to four attempts to switch on the hot-water auxiliary heater (stationary heater), waiting several minutes between each attempt (→ page 133).</li> </ul> <p data-bbox="400 483 997 531">If the hot-water auxiliary heater (stationary heater) does not switch on:</p> <ul style="list-style-type: none"> <li data-bbox="400 539 790 563">► Consult a qualified specialist workshop.</li> </ul>

## Lights

Display messages	Possible causes/consequences and ► Solutions
 <p data-bbox="109 791 337 839">Left dipped beam (example)</p>	<p data-bbox="387 703 792 727">* The corresponding light source is defective.</p> <p data-bbox="400 735 1020 759">Have defective LED lights replaced at a qualified specialist workshop.</p> <ul style="list-style-type: none"> <li data-bbox="400 767 916 791">► Observe the notes on changing a bulb (→ page 115).</li> <li data-bbox="400 799 981 855">► Replace the defective bulb at the front (→ page 116) or rear (→ page 117).</li> </ul> <p data-bbox="400 863 1003 935">ⓘ Vehicles with LED lights on the trailer: if the current falls below the minimum of 50 mA, a display message may appear even though the trailer lights are working properly.</p>
<p data-bbox="109 951 300 999">Adaptive Main-beam Assist inoperative</p>	<p data-bbox="387 951 796 975">* Adaptive Highbeam Assist is malfunctioning.</p> <ul style="list-style-type: none"> <li data-bbox="400 983 751 1007">► Switch high beam on/off manually.</li> <li data-bbox="400 1015 790 1038">► Consult a qualified specialist workshop.</li> </ul>
<p data-bbox="109 1054 342 1126">Adaptive Main-beam Assist currently unavailable See Owner's Manual</p>	<p data-bbox="387 1054 1020 1078">* Adaptive Highbeam Assist is deactivated and temporarily inoperative.</p> <p data-bbox="400 1086 708 1110">The following causes are possible:</p> <ul style="list-style-type: none"> <li data-bbox="412 1118 916 1142">• The windscreen is dirty in the camera's field of vision.</li> <li data-bbox="412 1150 891 1174">• Visibility is impaired due to heavy rain, snow or fog.</li> </ul> <ul style="list-style-type: none"> <li data-bbox="400 1198 1025 1294">► Clean the windscreen. When the system detects that the camera is fully operational, the display will show the message <b>Adaptive Main-beam Assist available again</b></li> </ul> <p data-bbox="434 1302 854 1326">Adaptive Highbeam Assist is operational again.</p>
<p data-bbox="109 1342 344 1390">Active Light System inoperative</p>	<p data-bbox="387 1342 695 1366">* The active light function is faulty.</p> <ul style="list-style-type: none"> <li data-bbox="400 1374 790 1398">► Consult a qualified specialist workshop.</li> </ul>

Display messages	Possible causes/consequences and ► Solutions
 <p data-bbox="87 252 303 276">AUTO lights inoperative</p>	<p data-bbox="364 164 1001 212">* The light sensor is faulty. The automatic driving lights are malfunctioning.</p> <ul style="list-style-type: none"> <li data-bbox="381 220 930 244">► Switch the light functions on/off manually (→ page 109).</li> <li data-bbox="381 252 766 276">► Consult a qualified specialist workshop.</li> </ul>
<p data-bbox="87 300 314 347">Intell. Light System inoperative</p>	<p data-bbox="364 300 964 347">* The Intelligent Light System is malfunctioning. The lighting system remains available without the Intelligent Light System functions.</p> <ul style="list-style-type: none"> <li data-bbox="381 355 766 379">► Consult a qualified specialist workshop.</li> </ul>
 <p data-bbox="87 488 288 536">Malfunction See Owner's Manual</p>	<p data-bbox="364 395 717 419">* The exterior lighting is malfunctioning.</p> <ul style="list-style-type: none"> <li data-bbox="381 427 766 451">► Consult a qualified specialist workshop.</li> </ul>



## Warning and indicator lamps



### Indicator and warning lamps on the instrument cluster



Some systems will perform a self-test when the vehicle is switched on. Some indicator and warning lamps may briefly light up or flash. This behaviour is non-critical. These indicator and warning lamps indicate a malfunction only if they light up or flash after the vehicle has been started or during a journey.

### Safety systems



Warning/indicator lamp	Possible causes/consequences and ► Solutions
 <p data-bbox="87 1080 311 1128">Restraint system warning lamp</p>	<p data-bbox="364 992 960 1040">*The red restraint system warning lamp is on while the vehicle is on. The restraint system is malfunctioning.</p> <div style="border: 1px solid gray; padding: 5px; margin: 5px 0;"> <p data-bbox="378 1064 956 1112"><b>▲ WARNING</b> Risk of injury due to malfunctions in the restraint system</p> <p data-bbox="381 1128 972 1176">Components in the restraint system may be activated unintentionally or not deploy as intended in an accident.</p> <ul style="list-style-type: none"> <li data-bbox="381 1184 956 1232">► Have the restraint system checked and repaired immediately at a qualified specialist workshop.</li> </ul> </div> <ul style="list-style-type: none"> <li data-bbox="367 1264 740 1287">► Pay attention to the display messages.</li> <li data-bbox="367 1295 557 1319">► Drive on carefully.</li> <li data-bbox="367 1327 1001 1375">► Have the restraint system and its components checked immediately at a qualified specialist workshop.</li> </ul> <p data-bbox="367 1391 997 1439">Further information on the restraint system and its components can be found under "Occupant safety".</p>

Warning/indicator lamp	Possible causes/consequences and ► Solutions
 <p>Brake system warning lamp</p>	<p>*The red brake system warning lamp is on while the vehicle is on. EBD is unavailable due to a malfunction. This means that ABS, BAS, Hill Start Assist and ESP® as well as its driving safety systems, for example, are also unavailable.</p> <p>ATTENTION ASSIST is deactivated and other driving systems could be automatically deactivated.</p> <div style="background-color: #f0f0f0; padding: 5px; margin-top: 10px;"> <p><b>▲ WARNING</b> Risk of skidding if EBD, ABS and ESP® are malfunctioning</p> <p>The wheels may block during braking and ESP® does not perform any vehicle stabilization.</p> <p>The steerability and braking characteristics are heavily impaired and the braking distance may increase. In addition, other driving safety systems are switched off.</p> <ul style="list-style-type: none"> <li>► Drive on carefully.</li> <li>► Have the brake system checked immediately at a qualified specialist workshop.</li> </ul> </div> <ul style="list-style-type: none"> <li>► Switch off the vehicle, wait a short while, then switch it on again.</li> <li>► Check whether the display message has disappeared and ESP® is operational.</li> </ul> <p>If the display message continues to be shown:</p> <ul style="list-style-type: none"> <li>► Drive on carefully.</li> <li>► Consult a qualified specialist workshop immediately.</li> </ul>
 <p>Brake system warning lamp</p>	<p>*The red brake system warning lamp is on while the vehicle is on. A warning tone also sounds.</p> <p>The brake force boosting is malfunctioning.</p> <div style="background-color: #f0f0f0; padding: 5px; margin-top: 10px;"> <p><b>▲ WARNING</b> Risk of accident and injury if brake force boosting is malfunctioning</p> <p>If brake force boosting is malfunctioning, increased brake pedal force may be necessary for braking. The braking characteristics may be impaired. The braking distance can increase in emergency braking situations.</p> <ul style="list-style-type: none"> <li>► Stop in a safe location immediately. Do not continue driving!</li> <li>► Consult a qualified specialist workshop.</li> </ul> </div> <ul style="list-style-type: none"> <li>► Secure the vehicle against rolling away.</li> </ul>
 <p>Brake system warning lamp</p>	<p>*The red brake system warning lamp is on while the vehicle is on. There is insufficient brake fluid in the brake fluid reservoir.</p> <div style="background-color: #f0f0f0; padding: 5px; margin-top: 10px;"> <p><b>▲ WARNING</b> Risk of an accident due to low brake fluid level</p> <p>If the brake fluid level is too low, the braking effect and the braking characteristics may be impaired.</p> <ul style="list-style-type: none"> <li>► Stop the vehicle as soon as possible, paying attention to road and traffic conditions. Do not continue driving.</li> </ul> </div>



Warning/indicator lamp	Possible causes/consequences and ► Solutions
	<ul style="list-style-type: none"> <li>► Consult a qualified specialist workshop.</li> <li>► Do not top up the brake fluid.</li> </ul>
 <p>ABS warning lamp</p>	<p>► Secure the vehicle against rolling away.</p> <p>*The yellow ABS warning lamp is on while the vehicle is on. ABS has been switched off due to a malfunction. As a result, BAS, Hill Start Assist and ESP® as well as its driving safety systems, for example, have also been switched off. ATTENTION ASSIST is deactivated and other driving systems could be automatically deactivated.</p> <p><b>▲ WARNING</b> Risk of skidding if ABS and ESP® are malfunctioning</p> <p>The wheels may block during braking and ESP® does not perform any vehicle stabilization. The steerability and braking characteristics are heavily impaired and the braking distance may increase. In addition, other driving safety systems are switched off.</p> <ul style="list-style-type: none"> <li>► Drive on carefully.</li> <li>► Have ABS and ESP® checked immediately at a qualified specialist workshop.</li> </ul> <p>► Switch off the vehicle, wait a short while, then switch it on again.</p> <p>► Check whether the display message has disappeared and ESP® is operational.</p> <p>If the display message continues to be shown:</p> <ul style="list-style-type: none"> <li>► Drive on carefully.</li> <li>► Consult a qualified specialist workshop immediately.</li> </ul> <p>If the ABS control unit is defective, other systems may be available only with restrictions or may be unavailable, e.g. the navigation system or the automatic transmission.</p>
 <p>ESP® warning lamp</p>	<p>*The yellow ESP® warning lamp flashes while the vehicle is in motion. ESP® or traction control intervenes because there is a risk of skidding or at least one wheel is spinning. Cruise control or Active Distance Assist DISTRONIC has been automatically switched off.</p> <ul style="list-style-type: none"> <li>► When pulling away, accelerate only as much as is necessary.</li> <li>► Depress the accelerator pedal less during your journey.</li> <li>► Adapt your driving style to suit the road and weather conditions.</li> <li>► Do not switch off ESP®.</li> </ul> <p>In exceptional cases, it may be better to switch off ESP® (→ page 155).</p>

Warning/indicator lamp	Possible causes/consequences and ► Solutions
 <p>ESP® warning lamp</p>	<p>*The yellow ESP® warning lamp is on while the vehicle is on. ESP®, BAS and Hill Start Assist are unavailable due to a malfunction. ATTENTION ASSIST is deactivated and other driving systems could be automatically deactivated.</p> <p><b>▲ WARNING</b> Risk of skidding if ESP® is malfunctioning</p> <p>If ESP® is malfunctioning, ESP® cannot carry out vehicle stabilisation. In addition, other driving safety systems are switched off.</p> <ul style="list-style-type: none"> <li>► Drive on carefully.</li> <li>► Have ESP® checked at a qualified specialist workshop.</li> </ul> <p>► Pay attention to the display messages.</p> <p>► Drive on carefully.</p> <p>► Consult a qualified specialist workshop immediately.</p>
 <p>ESP® OFF warning lamp</p>	<p>*The yellow ESP® OFF warning lamp is on while the vehicle is running or the ECO start/stop function is active. ESP® has been switched off.</p> <p><b>▲ WARNING</b> Risk of skidding when driving with ESP® deactivated</p> <p>ESP® does not act to stabilise the vehicle. The availability of further driving safety systems is also limited.</p> <ul style="list-style-type: none"> <li>► Drive on carefully.</li> <li>► Deactivate ESP® only for as long as the situation requires.</li> </ul> <p>If ESP® cannot be activated, ESP® is malfunctioning.</p> <ul style="list-style-type: none"> <li>► Have ESP® checked immediately at a qualified specialist workshop.</li> </ul> <p>► Switch ESP® on again.</p> <p>In exceptional cases, it may be better to switch off ESP® (→ page 155).</p> <p>► Adapt your driving style to suit the road and weather conditions.</p> <p>If ESP® cannot be switched on:</p> <ul style="list-style-type: none"> <li>► Drive on carefully.</li> <li>► Have ESP® checked at a qualified specialist workshop.</li> </ul>
 <p>Indicator lamp for parking brake</p>	<p>*The red indicator lamp for the parking brake flashes or is on and/or the yellow warning lamp for the parking brake is on. The parking brake is malfunctioning or the display shows an instruction to release the parking brake.</p> <p>If only the red indicator lamp for the parking brake lights up, the parking brake has been applied.</p> <p>Pay attention to the display messages.</p>

## Seat belt

Warning/indicator lamp	Possible causes/consequences and ► Solutions
 <p data-bbox="90 292 292 316">Seat belt warning lamp</p>	<p data-bbox="360 204 1001 252">*The red seat belt warning lamp lights up or flashes after the vehicle has started. A warning tone may also sound.</p> <p data-bbox="360 256 1005 304">For certain countries only: The red seat belt warning lamp lights up for a maximum of six seconds after the vehicle has been switched on.</p> <p data-bbox="360 309 978 357">The seat belt warning lamp reminds the driver and front passenger to fasten their seat belts.</p> <ul data-bbox="360 368 714 395" style="list-style-type: none"> <li>► Fasten your seat belt (→ page 33).</li> </ul>
 <p data-bbox="90 499 292 523">Seat belt warning lamp</p>	<p data-bbox="360 406 1001 454">*The red seat belt warning lamp lights up after the vehicle starts as soon as the driver's or front passenger door has been closed.</p> <p data-bbox="360 459 878 483">The driver's or front passenger's seat belt is not fastened.</p> <ul data-bbox="360 494 714 542" style="list-style-type: none"> <li>► Fasten your seat belt (→ page 33). The warning lamp will go out.</li> </ul> <p data-bbox="360 547 978 595">In vehicles with automatic front passenger airbag actuation, there are objects on the front passenger seat.</p> <ul data-bbox="360 606 978 683" style="list-style-type: none"> <li>► Take the objects off the front passenger seat and stow them in a well-secured place. The warning lamp will go out.</li> </ul>
 <p data-bbox="90 786 292 810">Seat belt warning lamp</p>	<p data-bbox="360 694 1001 742">*The red seat belt warning lamp flashes and an intermittent warning tone sounds.</p> <p data-bbox="360 746 1005 794">The driver's or front passenger's seat belt is not fastened. You are driving at a speed greater than 25 km/h or have briefly exceeded 25 km/h.</p> <ul data-bbox="360 805 1001 1008" style="list-style-type: none"> <li>► Fasten your seat belt (→ page 33). The warning lamp and the intermittent warning tone will go out.</li> <p data-bbox="360 853 1001 933">In vehicles with automatic front passenger airbag actuation, there are objects on the front passenger seat. You are driving at a speed greater than 25 km/h or have briefly exceeded 25 km/h.</p> <li>► Take the objects off the front passenger seat and stow them in a well-secured place. The warning lamp and the intermittent warning tone will go out.</li> </ul>

## Driving systems



Warning/indicator lamp	Possible causes/consequences and ► Solutions
 <p data-bbox="90 1243 322 1291">Warning lamp for distance warning function</p>	<p data-bbox="360 1150 990 1198">*The red distance warning lamp lights up while the vehicle is in motion. The distance to the vehicle in front is too small for the selected speed.</p> <ul data-bbox="360 1209 792 1235" style="list-style-type: none"> <li>► Increase the distance to the vehicle in front.</li> </ul>
 <p data-bbox="90 1398 322 1445">Warning lamp for distance warning function</p>	<p data-bbox="360 1305 1001 1353">*The red distance warning lamp lights up while the vehicle is in motion. A warning tone also sounds.</p> <p data-bbox="360 1358 1001 1406">You are approaching a vehicle or a stationary obstacle on your anticipated route at excessive speed.</p> <ul data-bbox="360 1417 990 1493" style="list-style-type: none"> <li>► Be ready to apply the brakes immediately.</li> <li>► Pay careful attention to the traffic situation. If necessary, apply the brakes or avoid an obstacle.</li> </ul>



Warning/indicator lamp	Possible causes/consequences and ► Solutions
	<p>You can find further information about the distance warning function in "Active Brake Assist" (→ page 157).</p>

Vehicle

Warning/indicator lamp	Possible causes/consequences and ► Solutions
 <p>Power steering system warning lamp</p>	<p>*The red power steering warning lamp is on while the vehicle is on. A warning tone also sounds. The power assistance for the steering could be malfunctioning. You may need to steer more forcefully.</p> <ul style="list-style-type: none"> <li>► Carefully continue to a qualified specialist workshop and have the steering checked immediately.</li> </ul>

Engine

Warning/indicator lamp	Possible causes/consequences and ► Solutions
 <p>Engine diagnostics warning lamp</p>	<p>*The yellow engine diagnostics warning lamp is on while the vehicle is on.</p> <p>There may be a malfunction in the following vehicle systems:</p> <ul style="list-style-type: none"> <li>• Engine management</li> <li>• Injection</li> <li>• Exhaust system</li> <li>• Ignition system (in vehicles with a petrol engine)</li> <li>• Fuel system</li> </ul> <p>This can cause the emissions limit values to be exceeded and the engine to run in emergency mode.</p> <ul style="list-style-type: none"> <li>► Have the vehicle checked immediately at a qualified specialist workshop.</li> </ul>
 <p>Fuel reserve warning lamp</p>	<p>*The yellow fuel reserve warning lamp is on while the vehicle is on. The fuel supply has dropped into the reserve range.</p> <p>Operation of the auxiliary heating (stationary heater) is deactivated in the reserve range.</p> <ul style="list-style-type: none"> <li>► Refuel the vehicle.</li> </ul>
 <p>Coolant warning lamp</p>	<p>*The red coolant warning lamp is on while the vehicle is running and the coolant temperature display is at the start of the scale. The temperature sensor for the coolant temperature display is defective.</p> <p>The coolant temperature is no longer being monitored. If the coolant is too hot, the engine may be damaged.</p> <ul style="list-style-type: none"> <li>► Stop the vehicle immediately in accordance with the traffic conditions and switch it off. Do not continue driving!</li> <li>► Secure the vehicle against rolling away.</li> <li>► Consult a qualified specialist workshop.</li> </ul>

Warning/indicator lamp	Possible causes/consequences and ► Solutions
 <p data-bbox="89 252 282 274">Coolant warning lamp</p>	<p data-bbox="356 165 887 210">*The red coolant warning lamp is on while the vehicle is on. The coolant level is too low.</p> <p data-bbox="365 220 954 264">If the coolant level is correct, the air supply to the radiator may be impaired or the radiator's electric fan may be faulty.</p> <p data-bbox="365 274 981 300">The coolant is too hot and the engine is not being adequately cooled.</p> <div data-bbox="374 322 1005 354" style="background-color: #f0f0f0; padding: 5px;"> <p data-bbox="378 328 869 354">▲ <b>WARNING</b> Risk of burns when opening the bonnet</p> </div> <p data-bbox="383 367 974 414">If you open the bonnet in the event of an overheated engine or fire in the engine compartment, the following situations may occur:</p> <ul data-bbox="389 427 965 507" style="list-style-type: none"> <li>• You may come into contact with hot gases.</li> <li>• You may come into contact with other escaping hot operating fluids.</li> </ul> <ul data-bbox="383 523 938 609" style="list-style-type: none"> <li>► Before opening the bonnet, allow the engine to cool down.</li> <li>► In the event of a fire in the engine compartment, keep the bonnet closed and call the fire service.</li> </ul> <ul data-bbox="365 635 1005 1161" style="list-style-type: none"> <li>► Pay attention to the display messages.</li> <li>► Stop the vehicle immediately in accordance with the traffic conditions and switch it off.</li> <li>► Secure the vehicle against rolling away.</li> <li>► Exit the vehicle and keep a safe distance from it until the engine has cooled down.</li> <li>► Check the coolant level and top up with coolant, complying with the instructions (→ page 231).</li> <li>► If the coolant has to be topped up frequently, have the engine cooling system checked at a qualified specialist workshop.</li> <li>► Ensure that the air supply to the radiator is not impaired, e.g. by a plastic bag that has been blown onto the grille.</li> <li>► Monitor the coolant temperature display on the instrument cluster.</li> <li>► Do not restart the engine until the coolant temperature is below 120°C. If you do, the engine may be damaged.</li> <li>► Drive on to the nearest qualified specialist workshop. Avoid high engine loads, e.g. driving in mountainous terrain or stop-and-go driving.</li> </ul>
 <p data-bbox="89 1262 282 1284">Coolant warning lamp</p>	<p data-bbox="356 1176 981 1220">*The red coolant warning lamp is on while the vehicle is on. A warning tone also sounds.</p> <p data-bbox="365 1230 996 1276">The coolant has exceeded the temperature of 120°C. The air supply to the radiator may be impaired or the coolant level may be too low.</p> <p data-bbox="365 1286 954 1311">The engine has not been sufficiently cooled and may be damaged.</p>

Warning/indicator lamp	Possible causes/consequences and ► Solutions
	<p><b>▲ WARNING</b> Risk of burns when opening the bonnet</p> <p>If you open the bonnet in the event of an overheated engine or fire in the engine compartment, the following situations may occur:</p> <ul style="list-style-type: none"> <li>• You may come into contact with hot gases.</li> <li>• You may come into contact with other escaping hot operating fluids.</li> </ul> <p>► Before opening the bonnet, allow the engine to cool down.</p> <p>► In the event of a fire in the engine compartment, keep the bonnet closed and call the fire service.</p> <p>► Pay attention to the display messages.</p> <p>► Stop the vehicle immediately in accordance with the traffic conditions and switch it off.</p> <p>► Secure the vehicle against rolling away.</p> <p>► Exit the vehicle and keep a safe distance from it until the engine has cooled down.</p> <p>► Check the coolant level and top up with coolant, complying with the instructions (→ page 231).</p> <p>► If the coolant has to be topped up frequently, have the engine cooling system checked at a qualified specialist workshop.</p> <p>► Ensure that the air supply to the radiator is not impaired, e.g. by a plastic bag that has been blown onto the grille.</p> <p>► Monitor the coolant temperature display on the instrument cluster.</p> <p>► If the coolant temperature is below 120°C, you can continue driving to the nearest qualified specialist workshop.</p> <p>► In doing so, avoid high engine loads, e.g. driving in mountainous terrain or stop-and-go driving.</p>

## Tyres

Warning/indicator lamp	Possible causes/consequences and ► Solutions
 <p>Tyre pressure monitoring system warning lamp</p>	<p>*The yellow tyre pressure monitoring system warning lamp (pressure loss/malfunction) is on. The tyre pressure monitoring system has detected a loss of pressure in at least one tyre.</p> <p><b>▲ WARNING</b> Risk of an accident due to insufficient tyre pressure</p> <ul style="list-style-type: none"> <li>• The tyres can burst.</li> <li>• The tyres can wear excessively and/or unevenly.</li> <li>• The driving characteristics as well as the steering and braking may be greatly impaired.</li> </ul> <p>You could then lose control of the vehicle.</p> <p>► Observe the recommended tyre pressures.</p> <p>► Adjust the tyre pressure if necessary.</p>

Warning/indicator lamp	Possible causes/consequences and ► Solutions
	<ul style="list-style-type: none"> <li>► Stop the vehicle without steering or braking suddenly. Pay attention to the traffic conditions.</li> <li>► Secure the vehicle against rolling away.</li> <li>► Pay attention to the display messages.</li> <li>► Check the tyres and, if necessary, replace the wheel (→ page 264).</li> <li>► Check the tyre pressure.</li> </ul> <p>In vehicles with steering-wheel buttons, you can check the tyre pressure electronically (→ page 261).</p> <ul style="list-style-type: none"> <li>► Correct the tyre pressure as necessary.</li> </ul>
<div style="border: 1px solid black; width: 100px; height: 100px; display: flex; align-items: center; justify-content: center; margin: 0 auto;">  </div> <p>Tyre pressure monitoring system warning lamp</p>	<p>*The yellow tyre pressure monitoring system warning lamp (pressure loss/malfunction) flashes for approximately one minute and then remains lit. The tyre pressure monitoring system is malfunctioning.</p> <div style="background-color: #f0f0f0; padding: 5px; border: 1px solid #ccc;"> <p><b>⚠ WARNING</b> There is a risk of an accident if the tyre pressure monitoring system is malfunctioning</p> </div> <p>The tyre pressure monitoring system cannot issue a warning if there is pressure loss in one or more of the tyres. Tyres with insufficient tyre pressure may impair the driving characteristics as well as steering and braking.</p> <ul style="list-style-type: none"> <li>► Have the tyre pressure monitoring system checked at a qualified specialist workshop.</li> </ul> <ul style="list-style-type: none"> <li>► Pay attention to the display messages.</li> <li>► Consult a qualified specialist workshop.</li> </ul>

## 1, 2, 3 ...

**4MATIC**

Function..... 147

**12 V socket**

see Socket (12 V)

**230 V socket**

see Socket (230 V)

**360° Camera**

Button..... 172

Care..... 235

Function..... 170

Opening the camera cover (reversing camera)..... 170

Switching automatic mode on/off (reversing camera)..... 172

**A****ABS (anti-lock braking system)**..... 155**Acceleration**

see Using kickdown

**Accident and Breakdown Management**

Mercedes me connect..... 197

**Acoustic locking verification signal**

Activating/deactivating..... 52

**Active Brake Assist**

Function/notes..... 157

Switching on/off..... 159

**Active Distance Assist DISTRONIC**

Calling up a speed..... 164

Displays..... 165

Function..... 163

Increasing/decreasing speed..... 164

Selecting..... 164

Storing a speed..... 164

Switching off/deactivating..... 164

Switching on/activating..... 164

System limitations..... 163

**Active light function**..... 111**Active Parking Assist**

Exiting a parking space..... 174

Function..... 172

Parking..... 173

System limits..... 172

**Adaptive brake lights**..... 159**Adaptive cruise control**

see Active Distance Assist DISTRONIC

**Adaptive Highbeam Assist**

Function..... 112

Switching on/off..... 113

**Adaptive Highbeam Assist Plus**

Function..... 113

Switching on/off..... 114

**AdBlue®**

Additive..... 150, 277

Displaying the fill level..... 150

Filling capacity..... 278

Notes..... 150

Purity..... 150, 277

Topping up..... 150

**Add-on equipment**..... 17**Add-on equipment guidelines**..... 17**Additive**

AdBlue®..... 150, 277

Engine oil..... 278

**Additives**

Fuel..... 275

**Additives (AdBlue®)**

see AdBlue®

**Additives (engine oil)**

see Additive

**Additives (fuel)**

see Fuel

**Adjusting the air vents**..... 131**After-sales service**

see ASSYST PLUS service interval display

**Air suspension**

see AIRMATIC

**Air-recirculation button**

Convenience opening/closing..... 130

**Airbag**

Activation..... 30

Automatic front passenger airbag sh

utoff..... 36

Front airbag..... 34

Installation locations..... 34

Overview..... 34

PASSENGER AIR BAG indicator lamp..... 37

Protection impaired..... 35

Protection provided..... 34

Side airbag..... 34

Window airbag..... 34

**AIRMATIC**

Suspension..... 147

**Alarm system**

see ATA (Anti-Theft Alarm system)

**All-wheel drive**

Notes..... 147

**All-wheel drive**

see 4MATIC

- Ambient lighting**  
 Setting (MBUX multimedia system)..... 115
- Android Auto**  
 see Smartphone integration
- Animals**  
 Pets in the vehicle..... 51
- Anti-lock braking system**  
 see ABS (anti-lock braking system)
- Anti-skid chains**  
 see Snow chains
- Anti-theft alarm system**  
 see ATA (Anti-Theft Alarm system)
- Anti-theft protection**  
 Immobiliser..... 69
- Anti-theft protection**  
 see ATA (Anti-Theft Alarm system)
- Anticipatory occupant protection**  
 see PRE-SAFE® (anticipatory occupant protection)
- Anticipatory occupant protection system**  
 see PRE-SAFE® (anticipatory occupant protection)
- Apple CarPlay®**  
 see Smartphone integration
- Aquaplaning**..... 141
- Armrest**  
 Stowage compartment..... 100
- Ashtray**  
 Rear passenger compartment..... 106  
 Use (front centre console)..... 105
- Assistance systems**  
 see Driving safety system
- Assistant display (on-board computer)**..... 187
- ASSYST**  
 see ASSYST PLUS service interval display
- ASSYST PLUS service interval display**  
 Displaying the service due date..... 226  
 Function/notes..... 226  
 Non-operational times with the battery disconnected..... 227  
 Regular maintenance work..... 226  
 Special service requirements..... 226
- ATA (Anti-Theft Alarm system)**  
 Activating/deactivating interior protection..... 70  
 Function..... 69  
 Interior motion sensor function..... 70  
 switching on/off..... 69  
 Switching tow-away protection on/off... 70  
 Tow-away protection function..... 70
- Attachments**..... 17
- ATTENTION ASSIST**  
 Function..... 175  
 Switching on/off..... 176  
 System limits..... 175
- Attention assistant**  
 see ATTENTION ASSIST
- Authorised workshop**  
 see Qualified specialist workshop
- Automatic co-driver airbag shutoff**  
 Function of co-driver airbag shutoff..... 36  
 PASSENGER AIR BAG indicator lamp..... 37
- Automatic distance adjustment**  
 see Active Distance Assist DISTRONIC
- Automatic driving lights**..... 109
- Automatic engine start**  
 ECO start/stop function..... 141
- Automatic engine stop**  
 ECO start/stop function..... 141
- Automatic measures after an accident**..... 39
- Automatic transmission**  
 DIRECT SELECT lever..... 143  
 Drive program display..... 146  
 Drive programs..... 146  
 DYNAMIC SELECT switch..... 146  
 Engage park position..... 145  
 Engage reverse gear..... 144  
 Engaging drive position..... 145  
 Engaging neutral..... 144  
 Kickdown..... 147  
 Manual shifting..... 146  
 Restricting the shift range..... 145  
 Selecting the drive program..... 146  
 Steering wheel gearshift paddles..... 146  
 Transmission position display..... 143  
 Transmission positions..... 143
- Auxiliary heating**  
 Notes..... 131
- Auxiliary warm-air heater**  
 Function..... 135  
 Immediate heating mode..... 136  
 Overview, timer..... 135  
 Problems..... 136  
 Setting the departure time..... 136  
 Setting the temperature/operating duration..... 136  
 Setting the timer..... 135
- Axle load**..... 273

## B

**Back support**

see Lumbar support (4-way)

**Ball coupling**

Attaching..... 180

**Ball neck**

Removing..... 181

**BAS (Brake Assist System)**..... 155**Battery**

Care..... 243

Charging..... 243

Charging a vehicle battery..... 243

Connecting and fitting the starter

battery..... 247

Disconnecting and removing the

starter battery..... 245

Jump-starting (vehicle)..... 243

Key..... 53

Notes (vehicle)..... 241

Remote control (stationary heating/  
ventilation)..... 134

**Belt**

see Seat belt

**Belt warning**

see Seat belt

**Blind Spot Assist**

Function..... 177

Rear Cross Traffic Alert..... 177

Switching on/off..... 177

System limits..... 177

**Bottle holder**..... 105**Brake**

ABS (anti-lock braking system)..... 155

Activating/deactivating the HOLD  
function..... 166

Active Brake Assist..... 157

Adaptive brake lights..... 159

BAS (Brake Assist System)..... 155

Braking with the parking brake..... 140

Downhill gradient..... 140

Driving instructions..... 140

EBD (Electronic Brakeforce Distribu-  
tion)..... 157

Heavy and light loads..... 140

HOLD function..... 166

Limited braking effect (salt-treated  
roads)..... 140

New brake disks and brakepads..... 140

New/replaced brake disks and  
brakepads..... 138

Running-in notes..... 138

Wet roadway..... 140

**Brake Assist System**

see BAS (Brake Assist System)

**Brake Assistance**

see BAS (Brake Assist System)

**Brake fluid**

Notes..... 279

**Brakeforce Distribution**

EBD (Electronic Brakeforce Distribu-  
tion)..... 157

**Breakdown**

Changing a wheel..... 264

Recovering the vehicle..... 250

Stuck vehicle..... 250

Tow-starting..... 252

Towing (both axles on the ground)..... 250

Towing away (raised front or rear  
axle)..... 251

Transporting the vehicle..... 251

**Breakdown**

see Flat tyre

**Buttons on the steering wheel**..... 8

## C

**Camera**

Information..... 154

**Camera**

see 360° Camera

see Reversing camera

**Car wash**

see Care

**Car wash (care)**..... 233**Car-to-X-Communication**

Displaying hazard warnings..... 209

**Care**

Automatic car wash..... 233

Carpet..... 236

Display..... 236

Exterior lighting..... 235

High-pressure cleaner..... 233

Instrument cluster..... 236

Matt finish..... 234

Paint..... 234

Plastic trim..... 236

Real wood/trim elements..... 236

Reversing camera..... 235

Reversing camera/360° Camera..... 235

Roof lining..... 236

Seat belt..... 236

Seat cover..... 236

Sensors..... 235

Tailpipes..... 235

- Trailer hitch..... 235
- Washing by hand..... 234
- Wheels/rims..... 235
- Windows..... 235
- Wiper blades..... 235
- Carpet (care)**..... 236
- Carrier systems**
  - Notes..... 224
- Centre console**
  - Between the seats (overview)..... 12
  - Lower section (overview)..... 11
  - Middle section (overview)..... 10
  - Stowage compartment..... 100
  - Top (overview)..... 9
- Changing a bulb**
  - see Changing bulbs
- Changing a wheel**
  - Lowering the vehicle..... 266
  - Preparing..... 264
  - Raising the vehicle..... 264
  - Removing a wheel..... 265
- Changing bulbs**
  - Light bulb types halogen headlamps... 116
  - Notes..... 115
- Changing lamps**
  - see Changing bulbs
- Charging**
  - Battery..... 243
- Child safety lock**
  - Hinged windows..... 51
  - Sliding door..... 50
- Child seat**
  - Approval categories..... 42
  - Attaching (notes)..... 42
  - Basic instructions..... 39
  - Front passenger seat (notes)..... 49
  - Front passenger seat (without auto-  
matic airbag shutoff)..... 48
  - ISOFIX (fitting)..... 45
  - Notes on risks and dangers..... 40
  - Recommendations for child  
restraint systems..... 41
  - Seats suitable for belt-secured child  
restraint systems..... 47
  - Seats suitable for ISOFIX child  
restraint systems..... 44
  - Securing on the co-driver's seat..... 49
  - Securing on the rear seat..... 48
  - Top Tether..... 46
- Children**
  - Avoiding dangers in the vehicle..... 40
  - Basic instructions..... 39
- Cigarette lighter**
  - Front centre console..... 106
- Cleaning**
  - see Care
- Climate control**
  - Activating/deactivating..... 127
  - Adjusting the air vents..... 131
  - Air distribution settings..... 128
  - Automatic control..... 128
  - Auxiliary heating..... 131
  - Auxiliary warm-air heater..... 135
  - Demisting the windscreen..... 129
  - Demisting windows..... 129
  - Hot-water auxiliary heater..... 132
  - Refrigerant..... 281
  - Setting the air distribution..... 128
  - Setting the airflow..... 128
  - Setting the temperature..... 129
  - Switching air-recirculation mode  
on/off..... 129
  - Switching residual heat utilisation  
on/off..... 130
  - Switching the A/C function on/off..... 127
  - Switching the rear window heater  
on/off..... 130
  - Switching the reset function on/off  
(control panel)..... 129
  - TEMPMATIC operating unit..... 125
  - THERMOTRONIC control panel..... 126
  - Ventilating the vehicle (convenience  
opening)..... 65
- Co-driver airbag shutoff**
  - see Automatic co-driver airbag shutoff
- Cockpit (overview)**..... 6
- Combination switch**
  - see Headlamp flashing
  - see High beam
  - see Turn signal light
- Comfort rear bench seat**
  - Adjusting the seat backrest..... 82
- Constant headlamp mode**
  - see Daytime running lights
- Convenience closing**..... 65
- Convenience opening**..... 65
- Convenience opening/closing**..... 130
- Conversions**..... 17
- Coolant**
  - Checking level..... 231
  - Filling capacities..... 280
  - Topping up..... 231

- Coolant (engine)**  
Notes..... 280
- Copyright**..... 29
- Cornering light**..... 111
- Crosswind Assist**  
Function/notes..... 156
- Cruise control**  
Activating..... 160  
Calling up a speed..... 160  
Deactivating..... 160  
Function..... 159  
Increasing/decreasing speed..... 160  
Lever..... 160  
Requirements..... 160  
Selecting..... 160  
Setting the speed..... 160  
Storing a speed..... 160  
System limits..... 159
- Cup holders**  
Rear..... 105  
Switching the cooling/heating function on/off..... 105
- D**
- Dashboard lighting**  
see Instrument lighting
- Data acquisition (vehicle)**..... 26
- Data protection rights**  
Data storage..... 29
- Data storage**  
Data protection rights..... 29  
Electronic control units..... 26  
Service provider..... 28
- Daytime running lights**  
Activating/deactivating..... 109  
Replacing light sources..... 116
- Deactivating the alarm (ATA)**..... 69
- Dealership**  
see Qualified specialist workshop
- Declaration of conformity**  
Electromagnetic compatibility..... 19  
Importer addresses..... 23  
Jack..... 23  
Specific absorption rate..... 19  
Wireless vehicle components..... 19
- Demisting windscreen**..... 129
- Destination entry**  
Entering a POI or address..... 207
- Diagnostics connection**..... 24
- Dialling a phone number (on-board computer)**..... 191
- Diesel**  
Low outside temperatures..... 276  
Notes..... 276
- Digital inside rearview mirror**..... 123
- Digital Owner's Manual**..... 15
- Dipped beam**  
Setting for abroad (symmetrical)..... 109
- DIRECT SELECT lever**  
Engage reverse gear..... 144  
Engaging drive position..... 145  
Engaging neutral..... 144  
Engaging park position automatically... 145  
Function..... 143  
Selecting park position..... 145  
Transmission positions..... 143
- Display (care)**..... 236
- Display (instrument cluster)**..... 186
- Display (multimedia system)**  
Home screen..... 200
- Display message**  
Calling up (on-board computer)..... 284  
Notes..... 284
- Distance adjustment**  
see Active Distance Assist DISTRONIC
- Distance control**  
see Active Distance Assist DISTRONIC
- Distance warning function**  
see Active Brake Assist
- DISTRONIC**  
see Active Distance Assist DISTRONIC
- Door**  
Locking (emergency key)..... 56  
Opening (from the inside)..... 54  
Switch automatic locking on/off (key)... 56  
Unlocking (emergency key)..... 56  
Unlocking (from the inside)..... 54
- Door control panel**..... 14
- Downhill driving**  
see DSR (Downhill Speed Regulation)
- Drive program display**..... 146
- Drive programs**  
see DYNAMIC SELECT
- Driver's seat**  
see Seat
- Driving characteristics (unusual)**..... 255
- Driving instructions**  
Brakes..... 140

- Downhill gradient..... 140
- General driving tips..... 139
- Limited braking effect (salt-treated roads)..... 140
- New brake disks and brakepads..... 140
- Parking brake..... 140
- Running-in notes..... 138
- Subjecting brakes to a load..... 140
- Wet roadway..... 140
- Driving lights**  
see Automatic driving lights
- Driving notes**  
Transport by rail..... 140
- Driving safety system**  
ABS (anti-lock braking system)..... 155
- Active Brake Assist..... 157
- Adaptive brake lights..... 159
- BAS (Brake Assist System)..... 155
- Cameras..... 154
- EBD (Electronic Brakeforce Distribution)..... 157
- ESP® Crosswind Assist..... 156
- ESP® trailer stabilisation..... 157
- Overview..... 155
- Radar and ultrasonic sensors..... 154
- Responsibility..... 154
- Driving system**  
see 360° Camera
- see Active Distance Assist DISTRONIC
- see Active Parking Assist
- see AIRMATIC
- see ATTENTION ASSIST
- see Blind Spot Assist
- see Cruise control
- see Driving safety system
- see HOLD function
- see Lane Keeping Assist
- see Limiter
- see PARKTRONIC
- see Reversing camera
- see Traffic Sign Assist
- Driving tips**  
Aquaplaning..... 141
- Driving abroad (symmetrical dipped beam)..... 109
- Driving on flooded roads..... 141
- Driving on wet roads..... 141
- Mountainous terrain..... 141
- Drowsiness detection**  
see ATTENTION ASSIST
- DSR (Downhill Speed Regulation)**  
Activating/deactivating..... 162
- Notes..... 161
- DYNAMIC SELECT**  
Drive program display..... 146
- Drive programs..... 146
- Function..... 146
- Operating..... 146
- Selecting the drive program..... 146
- E**
- E10**..... 275
- EASY-ENTRY easy entry and exit feature**  
Folding the EASY-ENTRY section  
forwards/back (rear bench seat)..... 81
- Using (luxury rear seat)..... 88
- Using (rear bench seat)..... 81
- Using (rear seat)..... 84
- EASY-PACK tailgate**  
Notes..... 61
- Opening and closing..... 61
- EBD (Electronic Brakeforce Distribution)**... 157
- ECO display**  
Activating..... 142
- Function..... 142
- ECO start/stop function**  
Automatic engine start..... 141
- Automatic engine stop..... 141
- Deactivating/activating..... 142
- Operation..... 141
- Electric parking brake**  
Applying automatically..... 153
- Applying or releasing manually..... 153
- Emergency braking..... 154
- Notes..... 152
- Releasing automatically..... 153
- Electric sliding door**  
Function..... 57
- Opening/closing (from the inside)..... 58
- Opening/closing (with the key)..... 59
- Opening/closing from the outside..... 59
- Opening/closing with the door handle... 59
- Opening/closing with the key..... 59
- Problems..... 60
- Programming the key..... 59
- Programming the key button..... 59
- Resetting..... 60
- Electric sliding door**  
see Electric sliding door
- Electromagnetic compatibility**  
Declaration of conformity..... 19
- Electronic Stability Program**  
see ESP® (Electronic Stability Program)
- Electronics**..... 272

- Emergency**
    - Fire extinguisher..... 238
    - First-aid kit (soft-sided)..... 238
    - Removing the warning triangle..... 238
    - Safety vest..... 238
    - Setting up the warning triangle..... 238
  - Emergency braking**
    - Electric parking brake..... 154
  - Emergency call**
    - see Mercedes-Benz emergency call system
  - Emergency key**
    - Locking a door..... 56
    - Removing/inserting..... 53
    - Unlocking a door..... 56
  - Engage reverse gear**..... 144
  - Engaging drive position (automatic transmission)**..... 145
  - Engaging neutral (automatic transmission)**..... 144
  - Engine**
    - ECO start/stop function..... 141
    - Engine number..... 273
    - Starting assistance..... 243
  - Engine electronics (notes)**..... 272
  - Engine number**..... 273
  - Engine oil**
    - Additive..... 278
    - Checking the oil level using the on-board computer..... 228, 229
    - Checking the oil level with a dipstick... 229
    - Filling capacity..... 279
    - Topping up..... 230
  - Engine output**
    - Notes on changes..... 25
  - Engine pre-heating**
    - see Auxiliary heating
  - Environmental protection**
    - Notes..... 16
    - Take-back of end-of-life vehicles..... 16
  - ERA-GLONASS test mode**
    - Starting/ending..... 241
  - ESC (Electronic Stability Control)**
    - see ESP® (Electronic Stability Program)
  - ESP®**
    - Crosswind Assist..... 156
    - Trailer stabilisation..... 157
  - ESP® (Electronic Stability Program)**
    - Activating/deactivating (on-board computer)..... 156
    - Function/notes..... 155
  - Switching on/off (button)..... 156
  - Exterior lighting**
    - Care..... 235
  - Exterior lighting**
    - see Lights
- F**
- Factory settings**
    - MBUX..... 204
  - Fatigue detection**
    - see ATTENTION ASSIST
  - Fault message**
    - see Display message
  - Filling up the windscreen washing system**..... 232
  - Fire extinguisher**..... 238
  - First-aid kit (soft-sided)**..... 238
  - Flat tyre**
    - Changing a wheel..... 264
    - Notes..... 241
  - Fog light (extended range)**..... 112
  - Foil covering**
    - Radar and ultrasonic sensors..... 154
  - Folding table**
    - Fitting/removing..... 102
    - Moving..... 102
    - on the seat backrest of the driver/ front passenger seat..... 104
    - Using..... 103
  - Foreign trip**
    - Symmetrical dipped beam..... 109
  - Free software**..... 29
  - Frequencies**
    - Mobile phone..... 272
    - Two-way radio..... 272
  - Front airbag**..... 34
  - Front seats**
    - Rotating..... 77
  - Front wheel arch**
    - Fitting/removing the cover..... 116
    - Wing..... 116
  - Fuel**
    - Additives..... 275
    - Diesel..... 276
    - E10..... 275
    - Flexible fuel vehicles..... 275
    - Fuel reserve..... 277
    - Low outside temperatures..... 276
    - Petrol..... 275

- Quality (diesel)..... 276
  - Quality (petrol)..... 275
  - Refuelling..... 148
  - Sulphur content..... 275
  - Tank content..... 277
  - Fuel consumption**
    - Displaying the average..... 187
  - Fuses**..... 253
- G**
- Gearshift lever**..... 143
  - Gearshift recommendation**
    - Manual shifting (automatic transmission)..... 146
    - Manual transmission..... 143
  - General operating permit number (EC)**..... 273
  - Glasses compartment**..... 101
  - Glove compartment**
    - Opening/closing..... 101
- H**
- Handbrake (electrical)**
    - see Electric parking brake
  - Hazard warning light system**
    - Switching on/off..... 110
  - Head restraint**
    - Adjusting electrically..... 96
    - Adjusting mechanically..... 96
  - Headlamp flashing**..... 110
  - Help call**
    - see Mercedes-Benz emergency call system
  - High beam**
    - Adaptive Highbeam Assist Plus..... 113
    - Replacing light sources..... 116
    - Switching on/off..... 110
  - High-pressure cleaner (care)**..... 233
  - Highbeam**
    - Adaptive Highbeam Assist..... 112
  - Hill Start Assist**..... 166
  - Hinged windows**
    - Child safety lock..... 51
  - HOLD function**
    - Notes..... 166
    - Switching on/off..... 166
  - Home screen (media display)**..... 200
  - Hot-water auxiliary heater**
    - Activating/deactivating with button..... 133
    - Displays (remote control)..... 134
    - Function..... 132
  - Problems..... 135
  - Switching on/off by remote control..... 133
- I**
- Identification plate**
    - Engine..... 273
    - Refrigerant..... 281
    - Vehicle..... 273
  - Ignition key**
    - see Key
  - Ignition lock**..... 138
  - Immobiliser**..... 69
  - Implied warranty (vehicle)**..... 26
  - Importer addresses**
    - Wireless components..... 23
  - Indicator lamps**
    - see Warning/indicator lamps
  - Installations**..... 17
  - Instrument cluster**
    - Adjusting the lighting..... 186
    - Care..... 236
    - Displays..... 184
    - Information on the display..... 186
    - Notes on warning/indicator lamps..... 307
    - Overview of displays..... 184
    - Warning/indicator lamps overview..... 7
  - Instrument lighting**..... 186
  - Instrument panel**
    - see Cockpit (overview)
  - Intelligent Light System**
    - Active light function..... 111
    - Adaptive Highbeam Assist..... 112
    - Cornering light..... 111
    - Motorway mode..... 111
    - Overview..... 111
    - Switching on/off..... 112
  - Interior lighting**
    - Ambient lighting..... 115
    - Replacing light sources..... 118
    - Setting..... 114
    - Switch-off delay time..... 115
  - Interior motion sensor**
    - Function..... 70
    - Switching on/off..... 70
  - iPad® attachment**..... 108
  - iPhone®**
    - see Smartphone integration
  - ISOFIX child restraint system**
    - Seats suitable for attaching..... 44

**ISOFIX child seat anchor**

Fitting..... 45

**J****Jack**

Declaration of conformity..... 23  
Storage location..... 253  
Stowage compartment in the rear..... 254

**Jump-start connection point**..... 243

**K****Key**

Acoustic locking verification signal..... 52  
Battery..... 53  
Convenience opening..... 130  
Emergency key..... 53  
Fastening to keyring..... 53  
Functions..... 52  
Overview..... 52  
Problem..... 54  
Programming the button for the electric sliding door..... 59  
Starting the vehicle..... 138  
Unlocking setting..... 53

**Key positions**..... 138

**L****Lane Keeping Assist**

Activating/deactivating..... 178  
Function..... 178  
Sensitivity..... 179

**Language**

Notes..... 204  
Setting..... 204

**Lashing points**

Information..... 283  
Overview..... 220

**Level control**

see AIRMATIC

**Light switch (overview)**..... 109

**Lighting**

see Lights

**Lights**

Activating/deactivating the surround lighting..... 114  
Active light function..... 111  
Adaptive Highbeam Assist..... 112  
Adaptive Highbeam Assist Plus..... 113  
Adjusting the instrument lighting..... 186  
Automatic driving lights..... 109  
Combination switch..... 110  
Cornering light..... 111

Driving abroad (symmetrical dipped beam)..... 109  
Fog light (extended range)..... 112  
Hazard warning light..... 110  
Headlamp flashing..... 110  
High beam..... 110  
Intelligent Light System..... 111  
Light switch..... 109  
Low beam..... 109  
Motorway mode..... 111  
Parking lights..... 109  
Range..... 110  
Rear fog light..... 109  
Responsibility with lighting systems..... 109  
Standing lights..... 109  
Switch-off delay time..... 114  
Switching the Intelligent Light System on/off..... 112  
Turn signal light..... 110

**Limit speed for winter tyres**

Setting..... 161

**Limiter**

Activating..... 160  
Calling up a speed..... 160  
Deactivating..... 160  
Function..... 159  
Increasing/decreasing speed..... 160  
Kickdown..... 159  
Lever..... 160  
Permanent setting..... 161  
Requirements..... 160  
Selecting..... 160  
Setting the speed..... 160  
Storing a speed..... 160  
Switching off/deactivating..... 164  
Switching on/activating..... 164

**Limiting the opening angle (tailgate)**..... 62

**LINGUATRONIC**

Operable functions..... 201  
Starting..... 201

**Live Traffic Information**

Switching the traffic information display on..... 209

**Load compartment and rear interior lamps**

Replacing light sources..... 118

**Load distribution**..... 218

**Load protection net**..... 221

**Load securing**

Fitting and removing tie-down eyes..... 220  
Lashing points..... 220  
Notes..... 219

Removing/fitting a load protection net.....	221
<b>Load securing aid</b>	
Luggage compartment partition.....	222
Removing/fitting a load protection net.....	221
<b>Loading guidelines</b> .....	217
<b>Locking/unlocking</b>	
Opening the door (from the inside).....	54
Switch automatic locking on/off (key)...	56
Unlocking the door (from the inside).....	54
<b>Low beam</b>	
Replacing light sources.....	116
Switching on/off.....	109
<b>Lubricant additives</b>	
see Additive	
<b>Luggage compartment partition</b>	
Folding up/down.....	222
Removing/fitting.....	222
Stowage compartments.....	222
<b>Lumbar support (4-way)</b> .....	76
<b>Luxury rear seat</b>	
Adjusting electrically.....	89
Adjusting the head restraint.....	97
EASY-ENTRY easy entry and exit feature.....	88
Moving.....	90
<b>M</b>	
<b>M+S tyres</b> .....	255
<b>Maintenance</b>	
Notes.....	226
<b>Maintenance</b>	
see ASSYST PLUS service interval display	
<b>Malfunction</b>	
Restraint system.....	30
<b>Manual transmission</b>	
Engage reverse gear.....	143
Using the gearshift lever.....	143
<b>Map</b>	
Displaying online map contents.....	209
Displaying weather information.....	209
Moving.....	208
Selecting the map orientation.....	208
Setting the map scale.....	208
Switching motorway information on/off.....	208
<b>Matt finish (cleaning instructions)</b> .....	234
<b>Maximum gross vehicle weight</b> .....	273

<b>Maximum speed</b>	
see Limiter	
<b>MBUX multimedia system</b>	
Factory setting.....	204
Notes.....	199
Operating the touchscreen.....	200
Overview.....	199
<b>Media</b>	
Menu (on-board computer).....	190
Operating media playback (on-board computer).....	190
Overview of the functions and symbols.....	213
Selecting a media source (on-board computer).....	190
<b>Media display</b>	
Home screen.....	200
Operating.....	200
<b>Media mode</b>	
Connecting Bluetooth® audio equipment.....	214
<b>Medical aids</b> .....	26
<b>Memory function (seat)</b> .....	76
<b>Menu (on-board computer)</b>	
Assistant display.....	187
Media.....	190
Navigation.....	188
Radio.....	190
Service.....	187
Settings.....	192
Telephone.....	191
<b>Menu overview (on-board computer)</b> .....	186
<b>Mercedes me app</b>	
Calling up services.....	198
Calling up your user account.....	197
Unlinking the user account.....	198
<b>Mercedes me Apps</b>	
Information.....	197
<b>Mercedes me calls</b>	
Arranging a service appointment.....	195
Calling the Mercedes-Benz customer centre.....	194
Calling the Mercedes-Benz customer centre after automatic accident or breakdown detection.....	194
Consenting to data transfer.....	195
Information.....	194
Transferred data.....	195
<b>Mercedes me connect</b>	
Accident and Breakdown Management.....	197

Information.....	196
Making a call via the overhead control panel.....	194
Transferred data.....	197
<b>Mercedes-Benz emergency call system</b>	
Automatic emergency call.....	239
Data transfer.....	240
Information.....	239
Manual emergency call.....	240
Overview.....	239
Self-diagnosis.....	241
Starting/ending ERA-GLONASS test mode.....	241
<b>Mercedes-Benz service centre</b>	
see Qualified specialist workshop	
<b>Message (display section of the instrument display)</b>	
see Display message	
<b>Message memory.....</b>	284
<b>Mirrors</b>	
Digital inside rearview mirror.....	123
<b>Mirrors</b>	
see Outside mirrors	
<b>Mobile phone</b>	
Frequencies.....	272
Transmission output (maximum).....	272
<b>Mobile phone</b>	
see Mobile phone	
see Smartphone integration	
see Telephone	
<b>Model series</b>	
see Vehicle identification plate	
<b>Motorway mode.....</b>	111
<b>Mounting a load.....</b>	217

## N

<b>Navigation</b>	
Activating.....	205
Displaying/hiding the menu.....	205
Menu (on-board computer).....	188
Overview.....	206
<b>Navigation</b>	
see Destination entry	
see Map	
see Route	
<b>Navigation instructions (on-board computer).....</b>	188

## O

<b>Occupant safety</b>	
see Airbag	
see Automatic co-driver airbag shutoff	
see Automatic measures after an accident	
see Child seat	
see Pets in the vehicle	
see PRE-SAFE® (anticipatory occupant protection)	
see Restraint system	
see Seat belt	
<b>On-board computer</b>	
Assistant display menu.....	187
Digital speedometer.....	187
Display.....	186
Displaying the service due date.....	226
Media menu.....	190
Menu navigation.....	188
Menu overview.....	186
Operation.....	184
Overview.....	184
Radio menu.....	190
Service menu.....	187
Settings menu.....	192
Showing the range.....	187
Telephone menu.....	191
Trip menu.....	187
<b>On-board diagnostic interface</b>	
see Diagnostics connection	
<b>On-board electronics</b>	
Engine electronics.....	272
Notes.....	272
Two-way radios.....	272
<b>Onboard Logic Unit</b>	
Online services.....	28
Vehicle data storage.....	28
<b>Online services</b>	
Data storage.....	28
<b>Open-source software.....</b>	29
<b>Opening/closing the bonnet.....</b>	227
<b>Operating fluids</b>	
AdBlue®.....	277
Additives (fuel).....	275
Brake fluid.....	279
Coolant (engine).....	280
Engine oil.....	278
Fuel (diesel).....	276
Fuel (petrol).....	275
Notes.....	274
Windscreen washer fluid.....	280
<b>Operating safety</b>	
Changes in the engine output.....	25

Declaration of conformity (electromagnetic compatibility).....	19
Declaration of conformity (Jack).....	23
Declaration of conformity (wireless vehicle components).....	19
Information.....	18
<b>Operating sun visor</b> .....	124
<b>Original parts</b> .....	16
<b>Outside mirrors</b>	
Anti-dazzle mode (automatic).....	124
folding in/out.....	122
Setting.....	122
Setting options.....	14
<b>Overhead control panel</b>	
Adjusting the interior lighting.....	114
Overview.....	13
<b>Owner's Manual (digital)</b> .....	15
<b>Owner's Manual (vehicle equipment)</b> .....	17
<b>P</b>	
<b>Paint (cleaning instructions)</b> .....	234
<b>Paint code</b> .....	273
<b>Panorama sliding sunroof</b>	
Closing.....	67
Notes.....	66
Opening.....	67
Opening/closing the roller sunblind.....	67
Problems.....	69
<b>Park position</b>	
Engaging.....	145
Engaging automatically.....	145
<b>Parking aid</b>	
see PARKTRONIC	
<b>Parking brake (electrical)</b>	
see Electric parking brake	
<b>Parking lights</b> .....	109
<b>Parking up</b> .....	154
<b>PARKTRONIC</b>	
Function.....	167
Switching on/off.....	168
<b>PASSENGER AIR BAG status indicator</b>	
see Automatic co-driver airbag shutoff	
<b>Permissible axle load</b> .....	273
<b>Permissible gross mass</b> .....	273
<b>Permissible towing methods</b> .....	248
<b>Petrol</b> .....	275
<b>Pets in the vehicle</b> .....	51
<b>Plastic trim (care)</b> .....	236
<b>Pop-out windows</b>	
Opening/closing.....	64
<b>Power supply</b>	
Activating.....	138
<b>PRE-SAFE® (anticipatory occupant protection)</b>	
Function.....	39
Reversing measures.....	39
<b>Profile</b>	
Creating a new profile.....	202
Notes.....	202
Selecting profile options.....	202
<b>Q</b>	
<b>QR code (rescue card)</b> .....	26
<b>Qualified specialist workshop</b> .....	25
<b>R</b>	
<b>Radar and ultrasonic sensors</b>	
Damage.....	154
<b>Radio</b>	
Menu (on-board computer).....	190
Overview of the functions and symbols.....	215
<b>REACH regulation</b> .....	26
<b>Real wood (care)</b> .....	236
<b>Rear and load compartment lamps</b>	
Replacing light sources.....	118
<b>Rear bench seat</b>	
Folding forwards and backwards.....	83
Moving.....	82
Notes.....	77
Using the easy entry and exit feature (EASY-ENTRY).....	81
<b>Rear bench seat</b>	
see Seat/bunk combination	
see Seats	
<b>Rear Cross Traffic Alert</b> .....	177
<b>Rear fog light</b> .....	109
<b>Rear luggage rack</b>	
Notes.....	224
<b>Rear seat</b>	
Adjusting the seat backrest.....	85
EASY-ENTRY easy entry and exit feature.....	84
Folding forwards and backwards.....	86
Installing and removing.....	87
Moving.....	85
<b>Rear seats</b>	
Notes.....	77
Seat anchorage.....	77

- Seating variants..... 77
- Rear window**
- Separately opening and closing..... 63
- Rear window wiper**
- Replacing..... 122
- Switching on/off..... 120
- Rear-view mirror**
- Anti-dazzle mode (automatic)..... 124
- Rear-view mirror**
- see Outside mirrors
- Recycling**
- see Take-back of end-of-life vehicles  
(environmental protection)
- Reducing agent**
- see AdBlue®
- Refrigerant (air conditioning)**
- Notes..... 281
- Refrigerator box**
- Switching on and off..... 108
- Refuelling**
- Displaying the AdBlue® level..... 150
- Refuelling the vehicle..... 148
- Topping up AdBlue®..... 150
- Registration**
- Vehicle..... 25
- Regulating headlamp range**..... 110
- Regulation of vehicle dynamics**
- see ESP® (Electronic Stability Program)
- Regulatory radio identification**
- Indonesia..... 273
- Small components..... 273
- Remote control (stationary heater/  
ventilation)**
- Setting..... 133
- Remote control (stationary heating/  
ventilation)**
- Displays..... 134
- Replacing the battery..... 134
- Replacing a wheel**
- Fitting a new wheel..... 265
- Replacing bulbs**
- Tail lamp types..... 117
- Tail lamps..... 117
- Replacing light sources**
- Daytime running lights..... 116
- Fitting/removing cover (front wheel  
arch)..... 116
- High beam..... 116
- Low beam..... 116
- Rear and load compartment lamps..... 118
- Standing/parking lights..... 116
- Surround lighting..... 118
- Turn signal light..... 116
- Rescue card**..... 26
- Resetting**
- MBUX reset function..... 204
- Resetting the trip computer**..... 187
- Residual heat utilisation**
- Switching on/off..... 130
- Restraint system**
- Basic instructions for children..... 39
- Function in an accident..... 30
- Functionality..... 30
- Malfunction..... 30
- Protection impaired..... 30
- Protection provided..... 30
- Self-test..... 30
- Warning lamps..... 30
- Restricting the shift range**..... 145
- Reversing camera**
- Care..... 235
- Function..... 168
- Opening the camera cover (360°  
Camera)..... 170
- Switching automatic mode on/off  
(360° Camera)..... 172
- Roll away protection**
- see HOLD function
- Roller sunblind**
- Panorama sliding sunroof..... 67
- Roof carrier**
- see Roof luggage rack
- Roof lining (care)**..... 236
- Roof luggage rack**
- Notes..... 224
- Route**
- Calculating..... 208
- Selecting options..... 208
- Running-in notes**..... 138

## S

- Safety systems**
- see Driving safety system
- Safety vest**..... 238
- Seat**
- Correct driver's seat position..... 72
- Seat belt**
- Activating/deactivating seat belt  
adjustment..... 33

- Adjusting the height..... 33
- Care..... 236
- Fastening..... 33
- Protection..... 31
- Protection impaired..... 32
- Releasing..... 33
- Seat belt adjustment (function)..... 33
- Warning lamps..... 33
- Seat belt adjustment**
  - Activating/deactivating..... 33
  - Function..... 33
- Seat belt tensioners**
  - Activation..... 30
- Seat cover (care)**..... 236
- Seat ventilation**
  - Switching on/off..... 99
- Seat/bunk combination**
  - Fitting/removing stowage compartment..... 101
  - Folding up the bed extension..... 93
  - Installing and removing..... 95
  - Installing/removing bed extension..... 93
  - Moving..... 93
  - Notes..... 91
  - Setting up/folding away the berth..... 93
- Seats**
  - 4-way lumbar support..... 76
  - Adjusting (electrically)..... 74
  - Adjusting (manually)..... 72
  - Adjusting armrests..... 77
  - Adjusting the head restraint electrically..... 96
  - Adjusting the head restraints mechanically..... 96
  - Installing and removing rear bench seat..... 84
  - Operating the memory function..... 76
  - Rotating (front seats)..... 77
  - Setting options..... 14
- Securing luggage**..... 217
- Selecting a gear**
  - see Shifting
- Selector lever**
  - see DIRECT SELECT lever
- Self-test**
  - Automatic co-driver airbag shutoff..... 37
- Sensors (care)**..... 235
- Service**
  - see ASSYST PLUS service interval display
- Service (on-board computer)**..... 187
- Service Centre**
  - see Qualified specialist workshop
- Service products**
  - Refrigerant (air conditioning)..... 281
- Setting a speed limit**
  - see Limiter
- Setting the airflow**..... 128
- Setting the map scale**
  - see Map
- Setting the speed**
  - see Cruise control
- Settings (on-board computer)**..... 192
- Shift paddles**
  - see Steering wheel gearshift paddles
- Shifting**
  - Gearshift recommendation (manual shifting, automatic transmission)..... 146
  - Gearshift recommendation (manual transmission)..... 143
- Short-distance trips**..... 140
- Showing the range**..... 187
- Side airbag**..... 34
- Side window**
  - Closing using the key..... 65
  - Convenience closing..... 65
  - Problems..... 66
- Side windows**
  - Adjusting..... 65
  - Closing..... 63
  - Convenience opening..... 65
  - Opening..... 63
  - Opening with the key..... 65
  - Opening/closing the pop-out window.... 64
- Sliding door**
  - Child safety lock..... 50
  - Closing (from the inside)..... 57
  - Closing (from the outside)..... 56
  - Opening (from the inside)..... 57
  - Opening (from the outside)..... 56
- Sliding sunroof**
  - see Panorama sliding sunroof
- Smartphone**
  - see Smartphone integration
  - see Telephone
- Smartphone integration**
  - Overview..... 212
- Snow chains**..... 256
- Socket (12 V)**
  - Front centre console..... 106

Rear.....	107	<b>Summer tyres</b> .....	255
<b>Socket (230 V)</b>		<b>Surround lighting</b>	
Rear.....	107	Activating/deactivating.....	114
<b>Software update</b>		<b>Surround View</b>	
System updates.....	203	see 360° Camera	
<b>Sound menu</b>		<b>Suspension</b>	
Functions overview.....	216	see AIRMATIC	
<b>Spare wheel</b>		<b>SVHC (substances of very high concern).....</b>	26
Fitting/removing.....	270	<b>Switch clock</b>	
Notes.....	269	Activating.....	135
<b>Specialist workshop</b>		Overview.....	135
see Qualified specialist workshop		Setting.....	135
<b>Specific absorption rate</b> .....	19	Setting the departure time.....	136
<b>Speedometer</b> .....	184	Setting the temperature/operating duration.....	136
<b>Standing lights</b> .....	109	Switching immediate heating mode on/off.....	136
<b>Standing/parking lights</b>		<b>Switch-off delay time</b>	
Replacing light sources.....	116	From outside.....	114
<b>Start/stop function</b>		Interior.....	115
see ECO start/stop function		<b>Switching air-recirculation mode on/off....</b>	129
<b>Starting assistance</b>		<b>Switching off engine</b>	
see Jump-start connection point		see Vehicle	
<b>Starting the engine</b>		<b>Switching on the ignition</b>	
see Vehicle		see Vehicle	
<b>Starting-off aid</b>		<b>Switching the A/C function on/off.....</b>	127
see Hill Start Assist		<b>Switching the rear window heater on/off...</b>	130
<b>Stationary heater</b>		<b>Switching the reset function on/off (control panel).....</b>	129
see Auxiliary heating		<b>System settings</b>	
<b>Stationary heater/ventilation</b>		MBUX reset function.....	204
Setting (remote control).....	133	Overview of the system settings menu.....	202
<b>Stationary heating</b>		<b>System settings</b>	
see Auxiliary warm-air heater		see Language	
<b>Stationary heating/ventilation</b>			
Displays (remote control).....	134		
<b>Stationary heating/ventilation</b>			
see Auxiliary warm-air heater			
see Hot-water auxiliary heater			
<b>Steering wheel</b>			
Adjusting.....	100		
<b>Steering wheel gearshift paddles</b> .....	146		
<b>Steering-wheel buttons</b> .....	8		
<b>Stowage compartment in the rear</b>			
Jack.....	254		
Vehicle tool kit.....	254		
<b>Stowage space</b>			
Glasses compartment.....	101		
<b>Suggestions</b>			
Configuring.....	202		
<b>Sulphur content</b> .....	275		

## T

### Table

see Folding table

<b>Tail lamps (replacing bulbs)</b> .....	117
---	-----













### Tailgate

Adjusting.....	62
EASY-PACK.....	61
Limiting the opening angle.....	62
Opening in an emergency.....	60
Opening/closing.....	60
Programming the key button.....	63
Separately opening rear window.....	63

<b>Tailpipes (care)</b> .....	235
-------------------------------	-----

- Take-back of end-of-life vehicles (environmental protection)**..... 16
- Tank content**
  - AdBlue®..... 278
  - Fuel..... 277
  - Reserve (fuel)..... 277
- Technical data**
  - Information..... 272
  - Mounting dimensions (trailer hitch).... 282
  - Notes (trailer hitch)..... 282
  - Regulatory radio identification (Indonesia)..... 273
  - Regulatory radio identification of small components..... 273
  - Vehicle identification plate..... 273
- Telephone**
  - Connecting a mobile phone (Pass-key)..... 212
  - Connecting a mobile phone (Secure Simple Pairing)..... 212
  - Functions in the telephone menu..... 212
  - Menu (on-board computer)..... 191
  - Notes..... 210
  - Operating modes..... 211
  - Telephone menu overview..... 211
- Telephone operating modes**
  - Bluetooth® Telephony..... 211
  - Business telephony..... 211
- Temperature**
  - Setting (heating/air conditioning)..... 129
- TEMPMATIC (operating unit)**..... 125
- THERMOTRONIC (control panel)**..... 126
- Tie-down eyes**..... 220
- To switch seat heating on/off**..... 98
- Tool**
  - see Vehicle tool kit
- Top Tether**..... 46
- Touch Control**
  - Operating..... 200
- Touchpad**
  - Operating..... 200
- Touchscreen**
  - Operating..... 200
- Tow-away protection**
  - Function..... 70
  - Switching on/off..... 70
- Tow-starting**..... 252
- Towing away**
  - Both axles on the ground..... 250
  - Raised front or rear axle..... 251
- Towing eye**
  - Fitting/removing..... 252
  - Storage location..... 252
- Towing methods**..... 248
- Traffic information**
  - Switching on the display..... 209
- Traffic Sign Assist**
  - Function/notes..... 176
  - Setting..... 177
  - System limits..... 176
- Trailer hitch**
  - Attaching the ball coupling..... 180
  - Care..... 235
  - Fitting the cover for trailer coupling.... 180
  - General notes..... 282
  - Information about trailer operation..... 179
  - Mounting dimensions..... 282
  - Removing the ball neck..... 181
  - Socket..... 182
- Trailer loads**..... 282
- Trailer operation**
  - Attaching the ball coupling..... 180
  - Coupling/Decoupling the trailer..... 182
  - Notes..... 179
  - Permissible axle load..... 273
  - Removing the ball neck..... 181
  - Socket..... 182
  - Trailer loads..... 282
- Trailer stabilisation**..... 157
- Transmission position display**..... 143
- Transport by rail**..... 140
- Transporting the vehicle (vehicle breakdown)**..... 251
- Trim element (care)**..... 236
- Turn signal indicators**
  - see Turn signal light
- Turn signal light**
  - Replacing light sources..... 116
  - Switching on/off..... 110
- Two-way radio telephone**
  - see Mobile phone
- Two-way radios**
  - Frequencies..... 272
  - Notes on installation..... 272
  - Transmission output (maximum)..... 272
- Tyre pressure**
  - Checking (tyre pressure monitoring system)..... 261
  - Notes..... 256
  - Restarting the tyre pressure monitor... 261

- Tyre pressure monitoring system (function)..... 260
  - Tyre pressure table..... 257
  - Tyre pressure monitor**
    - Checking the tyre pressures..... 261
    - Checking the tyre temperature..... 261
    - Function..... 260
  - Tyre pressure monitoring system**
    - Restarting..... 261
  - Tyre pressure table**..... 257
  - Tyre temperature**
    - Checking (tyre pressure monitoring system)..... 261
    - Tyre pressure monitoring system (function)..... 260
  - Tyre tread**..... 255
  - Tyres**
    - Checking..... 255
    - Checking the tyre pressure (tyre pressure monitoring system)..... 261
    - Direction of rotation..... 264
    - Fitting..... 265
    - Flat tyre..... 241
    - M+S tyres..... 255
    - Noise..... 255
    - Notes on fitting..... 261
    - Removing..... 265
    - Replacing..... 261, 264
    - Restarting the tyre pressure monitor... 261
    - Selection..... 261
    - Snow chains..... 256
    - Storing..... 264
    - Summer tyres..... 255
    - Tyre pressure (Notes)..... 256
    - Tyre pressure monitoring system (function)..... 260
    - Tyre pressure table..... 257
    - Unusual driving characteristics..... 255
    - Wheel size categories..... 263
    - Wheel/tyre combination..... 266
  - Tyres**
    - see Wheels
- U**
- Updates**
    - System updates..... 203
  - Using kickdown**..... 147
- V**
- Vehicle**
    - Correct use..... 25
    - Data acquisition..... 26
    - Deactivating..... 152
    - Diagnostics connection..... 24
    - Equipment..... 17
    - Implied warranty..... 26
    - Locking (from the inside)..... 55
    - Locking/unlocking (emergency key)..... 56
    - Lowering..... 266
    - Medical aids..... 26
    - Parking..... 152
    - Parking up..... 154
    - QR code rescue card..... 26
    - Qualified specialist workshop..... 25
    - Raising..... 264
    - REACH regulation..... 26
    - Registration..... 25
    - Starting (key)..... 138
    - SVHC (substances of very high concern)..... 26
    - Switch automatic locking on/off (key)... 56
    - Switching on the power supply..... 138
    - Unlocking (from the inside)..... 55
    - Ventilating (convenience opening)..... 65
  - Vehicle camera**
    - Information..... 154
  - Vehicle data**
    - Vehicle height..... 281
    - Vehicle length..... 281
    - Vehicle width..... 281
    - Wheelbase..... 281
  - Vehicle data storage**
    - Onboard Logic Unit..... 28
  - Vehicle dimensions**..... 281
  - Vehicle emergency start**..... 252
  - Vehicle identification number**
    - see VIN
  - Vehicle identification plate**
    - EC general operating permit number... 273
    - Maximum permissible gross vehicle weight..... 273
    - Paint code..... 273
    - Permissible axle load..... 273
    - VIN..... 273
  - Vehicle key**
    - see Key
  - Vehicle maintenance**
    - see ASSYST PLUS service interval display
  - Vehicle sensors**
    - Information..... 154
  - Vehicle tool kit**
    - Information..... 253
    - Jack..... 253
    - Stowage compartment in the rear..... 254

- Towing eye..... 252
- VIN**
- Identification plate..... 273
- Reading out..... 273
- Seat..... 273
- Windscreen..... 273
- Vision**
- Demisting windows..... 129
- W**
- Warning system**
- see ATA (Anti-Theft Alarm system)
- Warning triangle**
- Removing..... 238
- Setting up..... 238
- Warning/indicator lamp**
-  ABS warning lamp..... 309
-  Brake system warning lamp..... 308
-  Coolant warning lamp..... 312, 313
-  Engine diagnostics warning lamp..... 312
-  ESP® OFF warning lamp..... 310
-  ESP® warning lamp..... 309, 310
-  Fuel reserve warning lamp..... 312
-  Indicator lamp for parking brake..... 310
-  Power steering system warning lamp..... 312
-  Restraint system warning lamp... 307
-  Seat belt warning lamp..... 311
-  Tyre pressure monitoring system warning lamp..... 314, 315
-  Warning lamp for distance warning function..... 311
- PASSENGER AIR BAG..... 37
- Warning/indicator lamps**
- Notes..... 307
- Overview..... 7
- Warranty**..... 26
- Washer fluid**
- see Windscreen washer fluid
- Washing by hand (care)**..... 234
- Washing the engine**..... 233
- Weather information**..... 209
- Web browsers**
- Overview..... 213
- Wheel rotation**..... 263
- Wheels**
- Care..... 235
- Changing..... 263
- Checking..... 255
- Checking the tyre pressure (tyre pressure monitoring system)..... 261
- Fitting..... 265
- Flat tyre..... 241
- Noise..... 255
- Notes on fitting..... 261
- Removing..... 265
- Replacing..... 261, 264
- Restarting the tyre pressure monitor... 261
- Selection..... 261
- Snow chains..... 256
- Storing..... 264
- Technical data..... 266
- Tyre pressure (Notes)..... 256
- Tyre pressure monitoring system (function)..... 260
- Tyre pressure table..... 257
- Unusual driving characteristics..... 255
- Wheel size categories..... 263
- Wheel/tyre combination..... 266
- Wheels (care)**..... 235
- Wi-Fi**
- Setting..... 203
- Window airbag**..... 34
- Window lifter**
- see Side windows
- Windows**
- see Side windows
- Windows (care)**..... 235
- Windscreen**
- Demisting..... 129
- Replacing the wiper blades..... 120
- Windscreen**
- see Windscreen
- Windscreen washer fluid**..... 280
- Windscreen wipers**
- Replacing the wiper blades..... 120
- Switching on/off..... 120
- Windscreen wipers**
- see Rear window wiper
- Winter driving (snow chains)**..... 256
- Winter tyres**
- Set a permanent speed limit..... 161
- Wiper blades**
- Care..... 235
- Replacing (rear window)..... 122

Replacing (windscreen)..... 120

**Wireless components**

Importer addresses..... 23

**Wireless vehicle components**

Declaration of conformity..... 19

Specific absorption rate..... 19

**Workshop**

see Qualified specialist workshop





## Publication details

### Internet

Further information about Mercedes-Benz vehicles and about Mercedes-Benz AG can be found on the following websites:

<https://www.mercedes-benz.com>

<https://www.daimler.com>

### Documentation team

You are welcome to forward any queries or suggestions you may have regarding these Operating Instructions to the technical documentation team to the following address:

Mercedes-Benz AG, HPC: CAC, Customer Service,  
70546 Stuttgart, Germany

©Mercedes-Benz AG: Not to be reprinted, translated or otherwise reproduced, in whole or in part, without written permission from Mercedes-Benz AG.

### Vehicle manufacturer

Mercedes-Benz AG  
Mercedesstraße 120  
70372 Stuttgart  
Germany

Your operator's manuals



**Digital in the vehicle**

Familiarise yourself with the contents of the operator's manual directly via the vehicle's multimedia system (Menu item "Vehicle"). Start with the quick guide or deepen your knowledge with practical tips.



**Vehicle document wallet in the vehicle**

Here you can find information on operation, service work and the warranty for your vehicle in printed form.



**Digital on the Internet**

You can access the operator's manual on the Mercedes-Benz homepage.



**Digital as an app**

The Mercedes-Benz Guides app is available free of charge in common app stores.



Apple® iOS



Android™



4475842910Z102